

Boss™ Coupling System

- Features:** The spud part of the coupling serves as one half of the connection and is usually fixed to the equipment. The stem part that is clamped to the hose is the other half. The two halves are connected or disconnected by rotating the wing nut onto the spud. When connected they achieve a mechanical, as well as, a pressure seal.
- Services:** Boss couplings are all-purpose hose couplings, universally recommended for steam hose connections. They are also widely used for air, water, fluid petroleum, chemicals and liquid petroleum gas up to 1" ID. Boss couplings can be applied to many types of rubber, synthetic, plastic, metallic or semi-metallic hose. Consult the factory for specific media capabilities.
- Purpose:** Boss couplings supply a convenient threaded fitting to connect two lengths of hose, or a single length to a male or female threaded (NPT) outlet.
- Material:**
- Stem: ¼" - 1" plated steel, 1¼" - 4" plated iron, 6" tubular steel
 - Spud: ¼" - 1" plated steel, 1¼" - 6" plated iron
 - Wing nut: ¼" - 1" plated steel, 1¼" - 6" plated iron
- Seal Types:**
- Ground joint: copper or polymer seats
 - Washer: Klingersil® C-4401

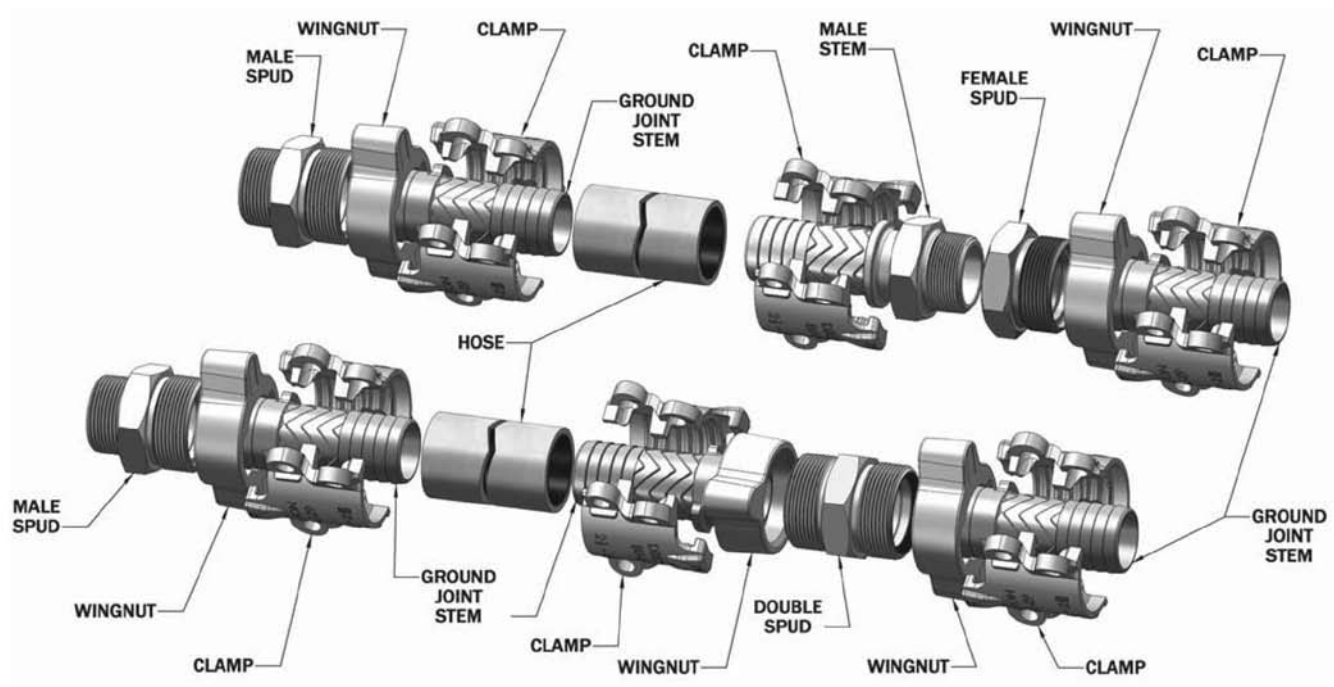

SAFETY ALERT

Worn-out hose couplings can be dangerous. They should be checked regularly and replaced when necessary. Each coupling user should review applications and add safety devices where indicated.