

**FULL PORT THREE-PIECE  
MOUNT DIRECT TYPE BALL  
VALVE BUTT WELD END  
1000W.O.G./PN63**

TC149 SUS316 A351Gr-CF8M

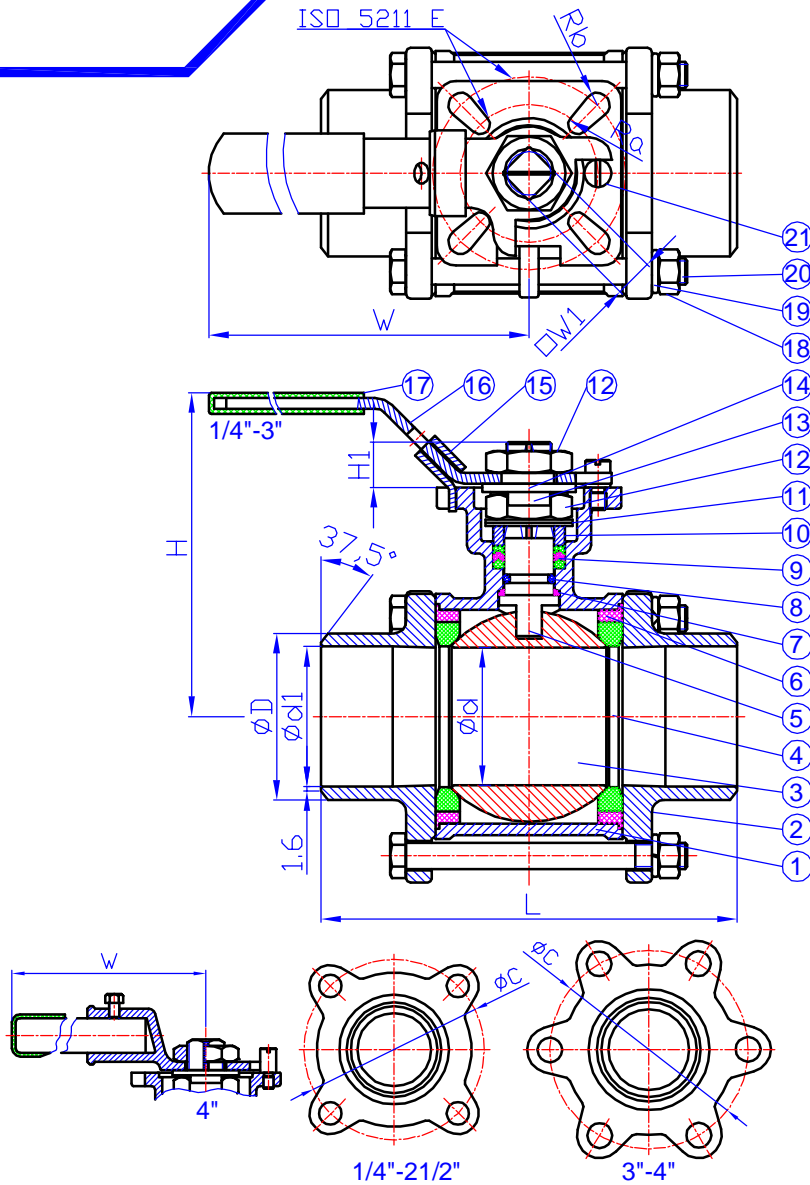

**FEATURES:**

- BUTT WELD END CAP:ISO1127,DIN2463, ANSI B36.19
- FACE TO FACE:DIN3202-S13
- BLOW-OUT PROOF STEM / FULL PORT
- WITH ISO 5211 MOUNTNG PAD
- INVESTMENT CASTING BODY
- 1000PSI(PN63)W.O.G.
- LOCKING DEVICE
- MATERIAL:  
SUS316/ASTM A351Gr-CF8M

**MATERIALS LIST:**

NO.	PART NAME	MATERIAL
1	BODY	CF8M
2	CAP	CF8M
3	BALL	CF8M
4	SEAT	PTFE
5	STEM	SUS316
6	GASKET	PTFE
7	THRUST WASHER	PEEK+PTFE
8	O-RING	VITON
9	PACKING	PTFE
10	GLAND	SUS304
11	SPRING WASHER	SUS304
12	STEM NUT	SUS304
13	STOP WASHER	SUS304
14	HANDLE WASHER	SUS304
15	LOCKING DEVICE	SUS304
16	HANDLE	SUS304
17	PLASTIC COVER	PLASTIC
18	HEX NUT	SUS304
19	BOLT WASHER	SUS304
20	JOINT BOLT	SUS304
21	STOP PIN	SUS304

**DIMENSIONS:**

SIZE		d	d1	L	H	W	C	D	ISO 5211	E	H1	W1	Ra	Rb	CV FACTOR
DN	NPS														
8	1/4"	11.6	10.0	70	74	123	52.0	17.2	F03-F04	36-42	9	9	R3	R3	6
10	3/8"	12.7	12.5	70	74	123	52.0	17.2	F03-F04	36-42	9	9	R3	R3	7
15	1/2"	15	16.0	75	74	123	52.0	21.3	F03-F04	36-42	9	9	R3	R3	10
20	3/4"	20	20.0	90	78	123	54.5	26.7	F03-F04	36-42	9	9	R3	R3	25
25	1"	25	25.0	100	89	153	63.5	33.6	F04-F05	42-50	11	11	R3	R3.5	35
32	1 1/4"	32	33.8	110	94	153	74.2	42.4	F04-F05	42-50	11	11	R3	R3.5	46
40	1 1/2"	38	39.5	125	110	183	84.0	48.0	F05-F07	50-70	14	14	R3.5	R4.5	80
50	2"	50	50.8	150	118	183	101	60.5	F05-F07	50-70	14	14	R3.5	R4.5	110
65	2 1/2"	65	62.7	190	161	246	132	76.1	F07-F10	70-102	17	17	R4.5	R5.5	310
80	3"	80	77.9	220	170	246	161.5	88.9	F07-F10	70-102	17	17	R4.5	R5.5	360
100	4"	100	100	270	202	395	191	114.2	F10-F12	102-125	22	22	R5.7	R6.7	820

