

Sight Flow Indicators (straight line)

with **flanged** connection acc. to **ANSI - 150 / 300 lbs**

NORIS

Bauform 880-A

Application:

The flow indicators are used for optical control of fluids and gases, for horizontal and vertical pipe lines. Also available with internal spinner or flap.

Operating conditions:

Working pressure: 16 bar by 150lbs
40 bar by 300lbs
Working temperature: 150°C or 280°C

Installation:

Optional; Take care of flow direction

Options:

with - Spinner or Flap
- Heating jacket
- Sight glass light - fitting

Materials:

Cast Iron GG 25 (EN-GJL-250) max. 16bar
Cast Steel GS-C 25 (1.0619 / GP240GH)
Stainless Steel WN 1.4408

Body	GG 25	GS-C 25	1.4408
Covers	GG 25 / S235JRG2	GS-C 25 / S235JRG2	1.4408 / 1.4301
Screws	4.6 / 5.6 gal.		A4-70
Glass	Borosilicate glass DIN 7080 Soda-lime glass DIN 8902		
Gaskets	Graphite, (or other materials)		

Certificate: (Option)

Acc. to EN 10204-2.2 or 3.1

Ordering example:

Sight Flow Indicators Bauform 880-A,
GS-C 25, borosilicate glass DIN 7080-16 bar
ANSI 2"; 150 lbs

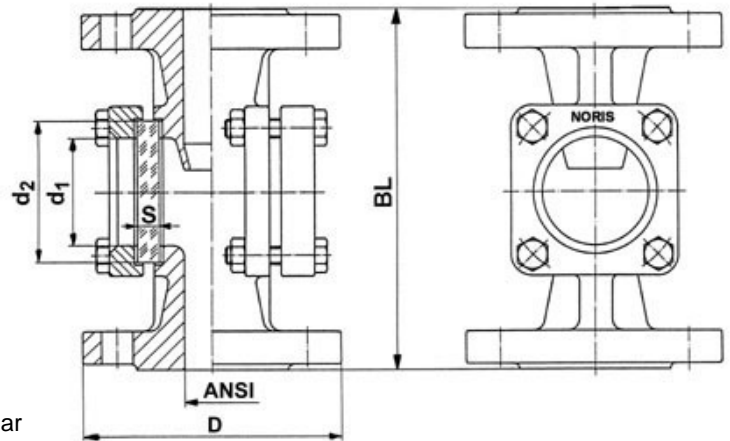

Dimensions:

ANSI	D		BL (DIN F1)	d ₁	Glass plate		
	150 lbs	300 lbs			d ₂	S	
					16 bar	40 bar	
1/2"	89	95,2	130	32	45	10	10
3/4"	98	117,3	150	32	45	10	10
1"	108	123,8	160	48	63	10	15
1 1/4"	118	133,4	180	48	63	10	15
1 1/2"	127	155,6	200	65	80	12	20
2"	152	165,1	230	80	100	15	25
2 1/2"	178	190,5	290	80	100	15	25
3"	191	209,6	310	100	125	20	30
4"	228 *	254,0	350	125	150	25	32
5"	254 *	279,4	400	150	175	25	a.A.
6"	279	317,5	480	175	200	30 **	a.A.
8"	343 *	381,0	600	175	200	30 **	a.A.

* by cast iron different diameter by D acc. to DIN

** 16 bar only with borosilicate glass poss ble