

**REF. 150**

**CAST IRON GATE VALVE PN10**



- Size :** DN 40 to DN 300  
**Ends :** Flanges GN10  
**Min Temperature :** - 10°C  
**Max Temperature :** + 90°C  
**Max Pressure :** 10 Bars  
**Specifications :** Rotating non rising stem and handwheel  
Inside screw stem  
Brass seat
- Materials :** Cast iron body

**REF. 150**

## **CAST IRON GATE VALVE PN10**

### **SPECIFICATIONS :**

- Single wedge disc
- Rotating non rising stem and handwheel
- Inside screw stem
- Graphite packing
- Brass seat
- Flanges R.F. GN10
- Painting RAL 7011 grey color, 90 µm thickness

### **USE :**

- For common fluids
- Min and max Temperature Ts : - 10°C to + 90°C
- Max Pressure PN : 10 bars

### **RANGE :**

- Cast iron body flanged R.F. GN10 **Ref. 150** from DN 40 to DN 300

**CAST IRON GATE VALVE PN10**

**MATERIALS :**

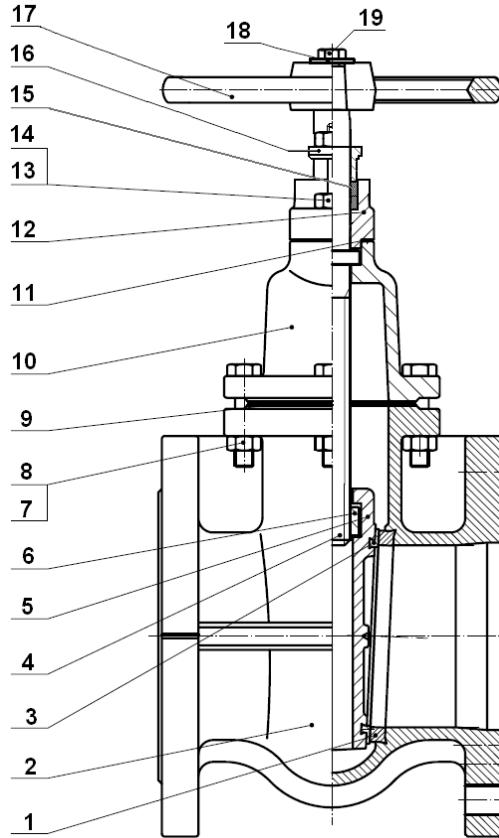

Item	Designation	Materials
1	Body seat	Brass
2	Body	Cast iron EN GJL-250
3	Wedge seat ring	Brass
4	Stem	SS 420
5	Wedge disc	Cast iron EN GJL-250
6	Stem nut	Brass
7	Bolt	Steel RSt37-2 ( 1.0038 )
8	Nut	Steel RSt37-2 ( 1.0038 )
9	Bonnet gasket	Graphite
10	Bonnet	Cast iron EN GJL-250
11	Stuffing box gasket	Graphite
12	Stuffing box	Ductile iron EN GJS-500-7
13	Bolt	Steel RSt37-2 ( 1.0038 )
14	Nut	Steel RSt37-2 ( 1.0038 )
15	Packing	Graphite
16	Gland follower	Ductile iron EN GJS-500-7
17	Handwheel	Cast iron EN GJL-250
18	Washer	Steel RSt37-2 ( 1.0038 )
19	Bolt	Steel RSt37-2 ( 1.0038 )

**CAST IRON GATE VALVE PN10**

SIZE ( in mm ) :

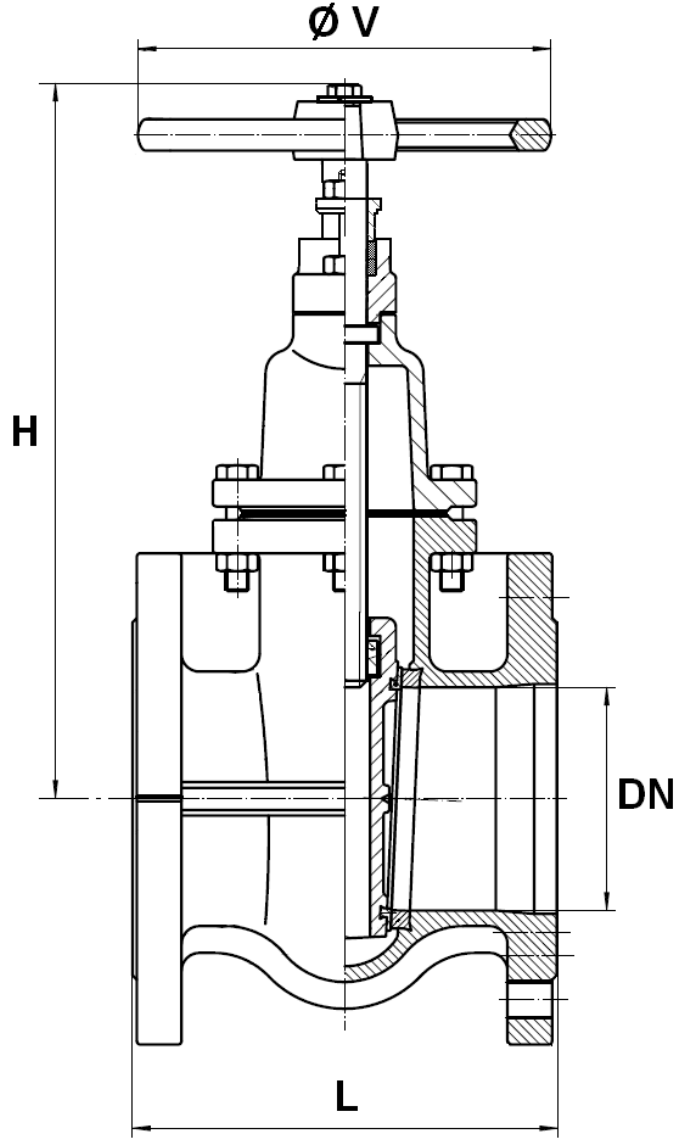

REF.	DN	40	50	65	80	100	125	150	200	250	300
150	L	140	150	170	180	190	200	210	230	250	270
	H	245	255	277	303	340	387	454	538	629	730
	Ø V	130	130	130	150	185	185	195	225	245	285
	Weight (Kg)	9.3	11.2	14	18.8	25	35.5	47	68	139	160

## CAST IRON GATE VALVE PN10

**FLANGES SIZE ( in mm ) :**

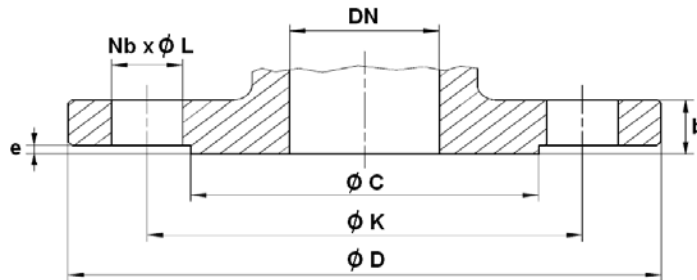

Ref.	DN	40	50	65	80	100	125	150	200	250	300
150	Ø C	80	102	124	140	158	188	212	268	320	370
	Ø D	150	165	185	200	220	250	285	340	395	445
	Ø K	110	125	145	160	180	210	240	295	350	400
	Nb x Ø L	4 x 19	4 x 19	4 x 19	8 x 19	8 x 19	8 x 19	8 x 23	8 x 23	12 x 23	12 x 23
	b	16	16	16	17	17	18	20	21	23	24
	e	2	2	2	2	2	3	3	3	3	4

**STANDARDS :**

- Fabrication according to ISO 9001 : 2000
- DIRECTIVE 97/23/CE : Products excluded from directive ( Article 1, § 3.2 )
- Length according to EN 558-1 series 14 ( DIN 3202 F4 )
- Flanged R.F. according to EN 1092-2 PN10
- Designing according to DIN 3352

**ADVICE :** Our opinion and our advice are not guaranteed and SFERACO shall not be liable for the consequences of damages. The customer must check the right choice of the products with the real service conditions.

**CAST IRON GATE VALVE PN10****INSTALLATION INSTRUCTIONS****GENERAL GUIDELINES :**

- Ensure that the valves to be used are appropriate for the conditions of the installation (type of fluid, pressure and temperature).
- Be sure to have enough valves to be able to isolate the sections of piping as well as the appropriate equipment for maintenance and repair.
- Ensure that the valves to be installed are of correct strength to be able to support the capacity of their usage.
- **Installation of all circuits should ensure that their function can be automatically tested on a regular basis (at least two times a year).**

**INSTALLATION INSTRUCTIONS :**

- **Before installing the valves, clean and remove any objects from the pipes** (in particular bits of sealing and metal) which could obstruct and block the valves.
- **Ensure that both connecting pipes either side of the valve (upstream and downstream) are aligned (if they're not, the valves may not work correctly).**
- **Make sure that the two sections of the pipe (upstream and downstream) match, the valve unit will not absorb any gaps. Any distortions in the pipes may affect the tightness of the connection, the working of the valve and can even cause a rupture.** To be sure, place the kit in position to ensure the assembling will work.
- **If sections of piping do not have their final support in place, they should be temporarily fixed. This is to avoid unnecessary strain on the valve.**
- Tighten the bolts in cross.
- It's recommended to operate the valve (open and close) 1 to 2 times per year