

BPE Fittings

BPE 45° Elbow Clamp End (DT-17)

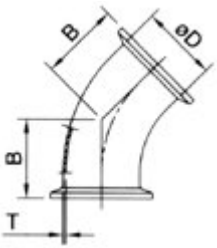

| SIZE | D | B | T |
|--------|-------|-------|------|
| 1/2" | 12.7 | 25.40 | 1.65 |
| 3/4" | 19.05 | 25.40 | 1.65 |
| 1" | 25.4 | 28.40 | 1.65 |
| 1-1/2" | 38.1 | 36.58 | 1.65 |
| 2" | 50.8 | 44.45 | 1.65 |
| 2-1/2" | 63.5 | 52.32 | 1.65 |
| 3" | 76.2 | 60.45 | 1.65 |
| 4" | 101.6 | 79.25 | 2.10 |

BPE 90° Elbow Clamp End (DT-16)

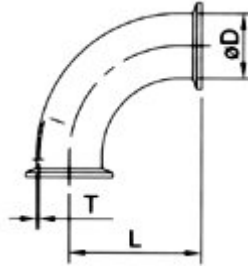

| SIZE | D | L | T |
|--------|-------|--------|------|
| 1/2" | 12.7 | 41.15 | 1.65 |
| 3/4" | 19.05 | 41.15 | 1.65 |
| 1" | 25.4 | 50.80 | 1.65 |
| 1-1/2" | 38.1 | 69.85 | 1.65 |
| 2" | 50.8 | 88.90 | 1.65 |
| 2-1/2" | 63.5 | 107.95 | 1.65 |
| 3" | 76.2 | 127.00 | 1.65 |
| 4" | 101.6 | 168.30 | 2.10 |

BPE Equal Tee Clamp End (DT-18)

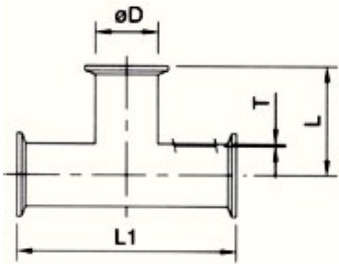

| SIZE | D | L | L1 | T |
|--------|-------|--------|-------|------|
| 1/2" | 12.7 | 57.20 | 114.4 | 1.65 |
| 3/4" | 19.05 | 60.20 | 120.6 | 1.65 |
| 1" | 25.4 | 66.55 | 133.4 | 1.65 |
| 1-1/2" | 38.1 | 72.90 | 146.0 | 1.65 |
| 2" | 50.8 | 85.60 | 171.4 | 1.65 |
| 2-1/2" | 63.5 | 92.95 | 182.2 | 1.65 |
| 3" | 76.2 | 98.30 | 196.8 | 1.65 |
| 4" | 101.6 | 120.65 | 241.4 | 2.10 |

BPE Equal Cross Clamp End (DT-18)

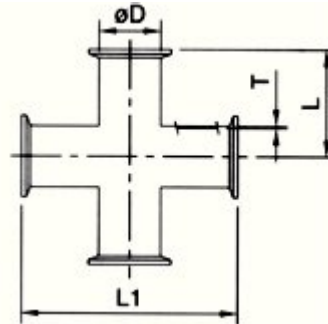

| SIZE | D | L | L1 | T |
|--------|-------|--------|-------|------|
| 1/2" | 12.7 | 57.20 | 114.4 | 1.65 |
| 3/4" | 19.05 | 60.20 | 120.6 | 1.65 |
| 1" | 25.4 | 66.55 | 133.4 | 1.65 |
| 1-1/2" | 38.1 | 72.90 | 146.0 | 1.65 |
| 2" | 50.8 | 85.60 | 171.4 | 1.65 |
| 2-1/2" | 63.5 | 92.95 | 182.2 | 1.65 |
| 3" | 76.2 | 98.30 | 196.8 | 1.65 |
| 4" | 101.6 | 120.65 | 241.4 | 2.10 |

BPE Short Outlet Tee Clamp End (DT-27)



| SIZE | D | L | L1 | T |
|--------|-------|-------|------|------|
| 1/2" | 12.7 | 57.2 | 25.4 | 1.65 |
| 3/4" | 19.05 | 60.3 | 28.6 | 1.65 |
| 1" | 25.4 | 66.7 | 28.6 | 1.65 |
| 1-1/2" | 38.1 | 73.0 | 34.9 | 1.65 |
| 2" | 50.8 | 85.7 | 41.3 | 1.65 |
| 2-1/2" | 63.5 | 92.1 | 47.6 | 1.65 |
| 3" | 76.2 | 98.4 | 54.0 | 1.65 |
| 4" | 101.6 | 120.7 | 69.9 | 2.10 |

BPE 180° U-Joint Clamp End (DT-24)

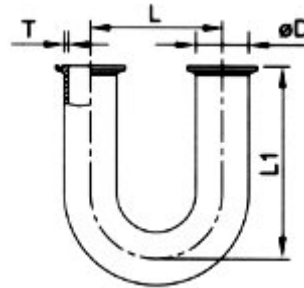

| SIZE | D | L | L1 | T |
|--------|-------|-------|-------|------|
| 1/2" | 12.7 | 114.3 | 88.9 | 1.65 |
| 3/4" | 19.05 | 114.3 | 88.9 | 1.65 |
| 1" | 25.4 | 114.3 | 88.9 | 1.65 |
| 1-1/2" | 38.1 | 114.3 | 127.0 | 1.65 |
| 2" | 50.8 | 152.4 | 139.7 | 1.65 |
| 2-1/2" | 63.5 | 190.5 | 158.8 | 1.65 |
| 3" | 76.2 | 228.6 | 177.8 | 1.65 |
| 4" | 101.6 | 304.8 | 231.8 | 2.10 |

BPE Fittings

BPE Reducing Tee Clamp End (DT-19)

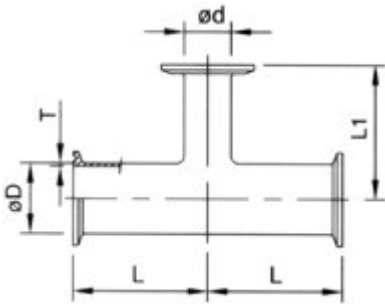

| SIZE | D | d | L | L1 | T |
|-----------------|-------|-------|------|------|------|
| 3/4" x 1/2" | 19.05 | 12.7 | 63.5 | 63.5 | 1.65 |
| 1" x 1/2" | 25.40 | 12.7 | 66.7 | 66.7 | 1.65 |
| 1" x 3/4" | 25.40 | 19.05 | 66.7 | 66.7 | 1.65 |
| 1-1/2" x 1/2" | 38.10 | 12.7 | 73.0 | 73.0 | 1.65 |
| 1-1/2" x 3/4" | 38.10 | 19.05 | 73.0 | 73.0 | 1.65 |
| 1-1/2" x 1" | 38.10 | 25.4 | 73.0 | 73.0 | 1.65 |
| 2" x 1" | 50.80 | 25.4 | 85.7 | 79.4 | 1.65 |
| 2" x 1-1/2" | 50.80 | 38.1 | 85.7 | 79.4 | 1.65 |
| 2-1/2" x 1" | 63.50 | 25.4 | 92.1 | 85.7 | 1.65 |
| 2-1/2" x 1-1/2" | 63.50 | 38.1 | 92.1 | 85.7 | 1.65 |

| SIZE | D | d | L | L1 | T |
|-------------|-------|------|-------|-------|------|
| 2-1/2" x 2" | 63.5 | 50.8 | 92.1 | 85.7 | 1.65 |
| 3" x 1" | 76.2 | 25.4 | 98.4 | 92.1 | 1.65 |
| 3" x 1-1/2" | 76.2 | 38.1 | 98.4 | 92.1 | 1.65 |
| 3" x 2" | 76.2 | 50.8 | 98.4 | 98.4 | 1.65 |
| 3" x 2-1/2" | 76.2 | 63.5 | 98.4 | 98.4 | 1.65 |
| 4" x 1" | 101.6 | 25.4 | 120.7 | 104.8 | 2.10 |
| 4" x 1-1/2" | 101.6 | 38.1 | 120.7 | 104.8 | 2.10 |
| 4" x 2" | 101.6 | 50.8 | 120.7 | 111.1 | 2.10 |
| 4" x 2-1/2" | 101.6 | 63.5 | 120.7 | 111.1 | 2.10 |
| 4" x 3" | 101.6 | 76.2 | 120.7 | 111.1 | 2.10 |

BPE Short Outlet Reducing Tee Clamp End (DT-20)

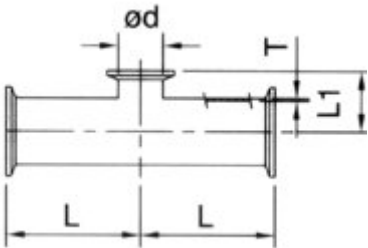

| SIZE | D | d | L | L1 | T |
|-----------------|-------|-------|------|------|------|
| 3/4" x 1/2" | 19.05 | 12.7 | 63.5 | 25.4 | 1.65 |
| 1" x 1/2" | 25.4 | 12.7 | 66.7 | 28.6 | 1.65 |
| 1" x 3/4" | 25.4 | 19.05 | 66.7 | 28.6 | 1.65 |
| 1-1/2" x 1/2" | 38.1 | 12.7 | 73.0 | 34.9 | 1.65 |
| 1-1/2" x 3/4" | 38.1 | 19.05 | 73.0 | 34.9 | 1.65 |
| 1-1/2" x 1" | 38.1 | 25.4 | 73.0 | 34.9 | 1.65 |
| 2" x 1" | 50.8 | 25.4 | 85.7 | 47.6 | 1.65 |
| 2" x 1-1/2" | 50.8 | 38.1 | 92.1 | 47.6 | 1.65 |
| 2-1/2" x 1" | 63.5 | 25.4 | 92.1 | 47.6 | 1.65 |
| 2-1/2" x 1-1/2" | 63.5 | 38.1 | 92.1 | 47.6 | 1.65 |

| SIZE | D | d | L | L1 | T |
|-------------|-------|------|-------|------|------|
| 2-1/2" x 2" | 63.5 | 50.8 | 92.1 | 47.6 | 1.65 |
| 3" x 1" | 76.2 | 25.4 | 98.4 | 54.0 | 1.65 |
| 3" x 1-1/2" | 76.2 | 38.1 | 98.4 | 54.0 | 1.65 |
| 3" x 2" | 76.2 | 50.8 | 98.4 | 54.0 | 1.65 |
| 3" x 2-1/2" | 76.2 | 63.5 | 98.4 | 54.0 | 1.65 |
| 4" x 1" | 101.6 | 25.4 | 120.7 | 66.7 | 2.10 |
| 4" x 2-1/2" | 101.6 | 38.1 | 120.7 | 66.7 | 2.10 |
| 4" x 2" | 101.6 | 50.8 | 120.7 | 66.7 | 2.10 |
| 4" x 2-1/2" | 101.6 | 63.5 | 120.7 | 66.7 | 2.10 |
| 4" x 3" | 101.6 | 76.2 | 120.7 | 66.7 | 2.10 |

BPE Concentric Reducer Clamp End (DT-21)

BPE Eccentric Reducer Clamp End (DT-21)

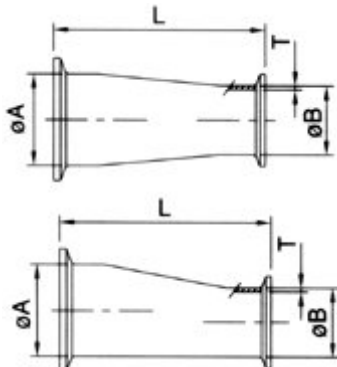

| SIZE | A | B | L | T |
|---------------|-------|-------|-------|------|
| 3/4" x 1/2" | 19.05 | 12.7 | 50.8 | 1.65 |
| 1" x 1/2" | 25.4 | 12.7 | 63.5 | 1.65 |
| 1" x 3/4" | 25.4 | 19.1 | 50.8 | 1.65 |
| 1-1/2" x 1/2" | 38.1 | 12.7 | 88.9 | 1.65 |
| 1-1/2" x 3/4" | 38.1 | 19.1 | 76.2 | 1.65 |
| 1-1/2" x 1" | 38.1 | 25.4 | 76.2 | 1.65 |
| 2" x 1/2" | 50.8 | 12.7 | 139.7 | 1.65 |
| 2" x 3/4" | 50.8 | 19.05 | 127.0 | 1.65 |
| 2" x 1" | 50.8 | 25.4 | 127.0 | 1.65 |
| 2" x 1-1/2" | 50.8 | 38.1 | 76.2 | 1.65 |

| SIZE | A | B | L | T |
|-----------------|-------|------|-------|------|
| 2-1/2" x 1-1/2" | 63.5 | 38.1 | 127.0 | 1.65 |
| 2-1/2" x 2" | 63.5 | 50.8 | 76.2 | 1.65 |
| 3" x 1-1/2" | 76.2 | 38.1 | 177.8 | 1.65 |
| 3" x 2" | 76.2 | 50.8 | 127.0 | 1.65 |
| 3" x 2-1/2" | 76.2 | 63.5 | 76.2 | 1.65 |
| 4" x 1-1/2" | 101.6 | 38.1 | 282.6 | 2.10 |
| 4" x 2" | 101.6 | 50.8 | 231.8 | 2.10 |
| 4" x 2-1/2" | 101.6 | 63.5 | 181.0 | 2.10 |
| 4" x 3" | 101.6 | 76.2 | 130.2 | 2.10 |

BPE Fittings

BPE 45° Elbow Weld End (DT-8)

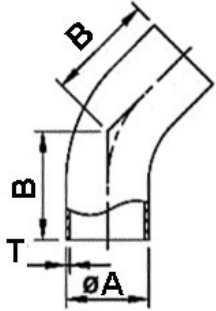

| SIZE | A | B | T |
|--------|-------|--------|------|
| 1/2" | 12.7 | 57.15 | 1.65 |
| 3/4" | 19.05 | 57.15 | 1.65 |
| 1" | 25.4 | 57.15 | 1.65 |
| 1-1/2" | 38.1 | 63.50 | 1.65 |
| 2" | 50.8 | 76.20 | 1.65 |
| 2-1/2" | 63.5 | 85.60 | 1.65 |
| 3" | 76.2 | 91.95 | 1.65 |
| 4" | 101.6 | 114.30 | 2.10 |

BPE 90° Elbow Weld End (DT-7)

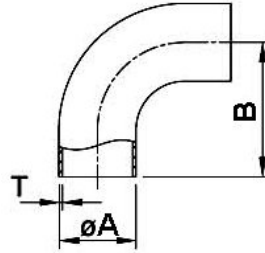

| SIZE | A | B | T |
|--------|-------|--------|------|
| 1/2" | 12.7 | 76.20 | 1.65 |
| 3/4" | 19.05 | 76.20 | 1.65 |
| 1" | 25.4 | 76.20 | 1.65 |
| 1-1/2" | 38.1 | 95.25 | 1.65 |
| 2" | 50.8 | 120.65 | 1.65 |
| 2-1/2" | 63.5 | 139.70 | 1.65 |
| 3" | 76.2 | 158.75 | 1.65 |
| 4" | 101.6 | 203.20 | 2.10 |

BPE Equal Tee Weld End (DT-9)

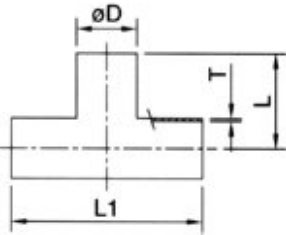

| SIZE | D | L | L1 | T |
|--------|-------|--------|-------|------|
| 1/2" | 12.7 | 47.50 | 95.2 | 1.65 |
| 3/4" | 19.05 | 50.80 | 101.6 | 1.65 |
| 1" | 25.4 | 53.85 | 108.0 | 1.65 |
| 1-1/2" | 38.1 | 60.20 | 120.6 | 1.65 |
| 2" | 50.8 | 73.00 | 146.0 | 1.65 |
| 2-1/2" | 63.5 | 79.25 | 158.8 | 1.65 |
| 3" | 76.2 | 85.60 | 171.4 | 1.65 |
| 4" | 101.6 | 104.65 | 209.6 | 2.10 |

BPE Equal Cross Weld End (DT-9)

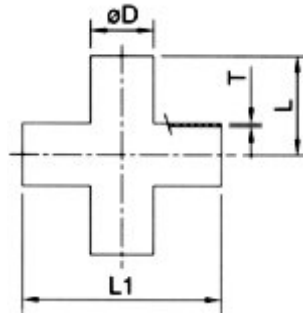

| SIZE | D | L | L1 | T |
|--------|-------|--------|-------|------|
| 1/2" | 12.7 | 47.50 | 95.2 | 1.65 |
| 3/4" | 19.05 | 50.80 | 101.6 | 1.65 |
| 1" | 25.4 | 53.85 | 108.0 | 1.65 |
| 1-1/2" | 38.1 | 60.20 | 120.6 | 1.65 |
| 2" | 50.8 | 73.00 | 146.0 | 1.65 |
| 2-1/2" | 63.5 | 79.25 | 158.8 | 1.65 |
| 3" | 76.2 | 85.60 | 171.4 | 1.65 |
| 4" | 101.6 | 104.65 | 209.6 | 2.10 |

BPE Reducing Tee Weld End (DT-10)

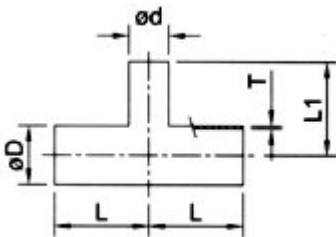

| SIZE | D | d | L | L1 | T |
|---------------|-------|-------|-------|-------|------|
| 3/4" x 1/2" | 19.05 | 12.7 | 50.8 | 50.80 | 1.65 |
| 1" x 1/2" | 25.4 | 12.7 | 54.0 | 53.85 | 1.65 |
| 1" x 3/4" | 25.4 | 19.05 | 54.0 | 53.85 | 1.65 |
| 1-1/2" x 1/2" | 38.1 | 12.7 | 60.3 | 60.20 | 1.65 |
| 1-1/2" x 3/4" | 38.1 | 19.05 | 60.3 | 60.20 | 1.65 |
| 1-1/2" x 1" | 38.1 | 25.4 | 60.3 | 60.20 | 1.65 |
| 2" x 1/2" | 50.8 | 12.7 | 72.9 | 66.55 | 1.65 |
| 2" x 3/4" | 50.8 | 19.05 | 72.9 | 66.55 | 1.65 |
| 2" x 1" | 50.8 | 25.4 | 72.9 | 66.55 | 1.65 |
| 2" x 1-1/2" | 50.8 | 38.1 | 72.9 | 66.55 | 1.65 |
| 2-1/2" x 1/2" | 63.5 | 12.7 | 79.25 | 72.90 | 1.65 |
| 2-1/2" x 3/4" | 63.5 | 19.05 | 79.25 | 72.90 | 1.65 |
| 2-1/2" x 1" | 63.5 | 25.4 | 79.25 | 72.90 | 1.65 |

| SIZE | D | d | L | L1 | T |
|-----------------|-------|-------|--------|-------|------|
| 2-1/2" x 1-1/2" | 63.5 | 38.1 | 79.4 | 73.0 | 1.65 |
| 2-1/2" x 2" | 63.5 | 50.8 | 79.4 | 73.0 | 1.65 |
| 3" x 1/2" | 76.2 | 12.7 | 85.6 | 79.25 | 1.65 |
| 3" x 3/4" | 76.2 | 19.05 | 85.6 | 79.25 | 1.65 |
| 3" x 1" | 76.2 | 25.4 | 85.6 | 79.25 | 1.65 |
| 3" x 1-1/2" | 76.2 | 38.1 | 85.6 | 79.25 | 1.65 |
| 3" x 2" | 76.2 | 50.8 | 85.6 | 79.25 | 1.65 |
| 3" x 2-1/2" | 76.2 | 63.5 | 85.6 | 79.25 | 1.65 |
| 4" x 1" | 101.6 | 25.4 | 104.65 | 91.95 | 2.10 |
| 4" x 1-1/2" | 101.6 | 38.1 | 104.65 | 91.95 | 2.10 |
| 4" x 2" | 101.6 | 50.8 | 104.65 | 98.30 | 2.10 |
| 4" x 2-1/2" | 101.6 | 63.5 | 104.65 | 98.30 | 2.10 |
| 4" x 3" | 101.6 | 76.2 | 104.65 | 98.30 | 2.10 |

BPE Equal Outlet Tee Weld/ Clamp End (DT-15)

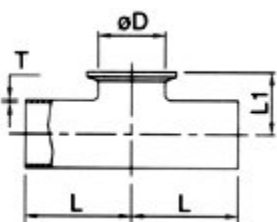

| SIZE | D | L | L1 | T |
|--------|-------|-------|------|------|
| 1/2" | 12.7 | 47.6 | 25.4 | 1.65 |
| 3/4" | 19.05 | 50.8 | 28.6 | 1.65 |
| 1" | 25.4 | 54.0 | 28.6 | 1.65 |
| 1-1/2" | 38.1 | 60.3 | 34.9 | 1.65 |
| 2" | 50.8 | 73.0 | 41.3 | 1.65 |
| 2-1/2" | 63.5 | 79.4 | 47.6 | 1.65 |
| 3" | 76.2 | 85.7 | 54.0 | 1.65 |
| 4" | 101.6 | 104.8 | 69.9 | 2.10 |

BPE 180° U-Joint Weld End (DT-23)

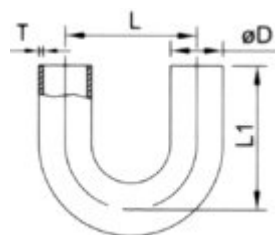

| SIZE | D | L | L1 | T |
|--------|-------|-------|-------|------|
| 1/2" | 12.7 | 114.3 | 76.2 | 1.65 |
| 3/4" | 19.05 | 114.3 | 76.2 | 1.65 |
| 1" | 25.4 | 114.3 | 76.2 | 1.65 |
| 1-1/2" | 38.1 | 152.4 | 114.3 | 1.65 |
| 2" | 50.8 | 152.4 | 127.0 | 1.65 |
| 2-1/2" | 63.5 | 190.5 | 146.1 | 1.65 |
| 3" | 76.2 | 228.6 | 165.1 | 1.65 |
| 4" | 101.6 | 304.8 | 215.9 | 2.10 |

BPE Fittings

BPE Concentric Reducer Weld End (DT-11)
BPE Eccentric Reducer Weld End (DT-11)

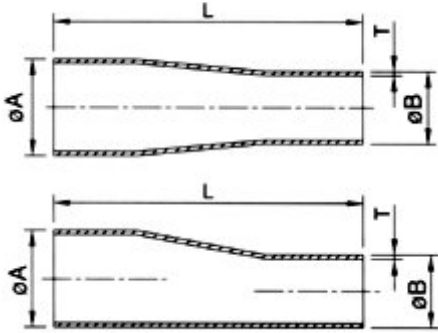

| SIZE | A | B | L | T |
|---------------|-------|-------|--------|------|
| 3/4" x 1/2" | 19.05 | 12.7 | 101.60 | 1.65 |
| 1" x 1/2" | 25.4 | 12.7 | 114.30 | 1.65 |
| 1" x 3/4" | 25.4 | 19.1 | 101.60 | 1.65 |
| 1-1/2" x 1/2" | 38.1 | 12.7 | 139.70 | 1.65 |
| 1-1/2" x 3/4" | 38.1 | 19.1 | 127.00 | 1.65 |
| 1-1/2" x 1" | 38.1 | 25.4 | 127.00 | 1.65 |
| 2" x 1/2" | 50.8 | 12.7 | 196.85 | 1.65 |
| 2" x 3/4" | 50.8 | 19.05 | 184.25 | 1.65 |
| 2" x 1" | 50.8 | 25.4 | 184.25 | 1.65 |
| 2" x 1-1/2" | 50.8 | 38.1 | 184.25 | 1.65 |

| SIZE | A | B | L | T |
|-----------------|-------|------|-------|------|
| 2-1/2" x 1-1/2" | 63.5 | 38.1 | 184.2 | 1.65 |
| 2-1/2" x 2" | 63.5 | 50.8 | 139.7 | 1.65 |
| 3" x 1-1/2" | 76.2 | 38.1 | 235.0 | 1.65 |
| 3" x 2" | 76.2 | 50.8 | 190.5 | 1.65 |
| 3" x 2-1/2" | 76.2 | 63.5 | 139.7 | 1.65 |
| 4" x 1-1/2" | 101.6 | 38.1 | 342.9 | 2.10 |
| 4" x 2" | 101.6 | 50.8 | 299.7 | 2.10 |
| 4" x 2-1/2" | 101.6 | 63.5 | 247.7 | 2.10 |
| 4" x 3" | 101.6 | 76.2 | 196.9 | 2.10 |

BPE 45° Elbow Weld/ Clamp End (DT-13)

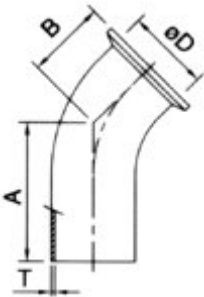

| SIZE | D | A | B | T |
|--------|-------|-------|-------|------|
| 1/2" | 12.7 | 57.15 | 25.40 | 1.65 |
| 3/4" | 19.05 | 57.15 | 25.40 | 1.65 |
| 1" | 25.4 | 57.15 | 28.45 | 1.65 |
| 1-1/2" | 38.1 | 63.50 | 36.80 | 1.65 |
| 2" | 50.8 | 76.20 | 44.45 | 1.65 |
| 2-1/2" | 63.5 | 85.60 | 52.32 | 1.65 |
| 3" | 76.2 | 91.95 | 60.45 | 1.65 |
| 4" | 101.6 | 114.3 | 79.25 | 2.10 |

BPE 90° Elbow Weld/ Clamp End (DT-12)

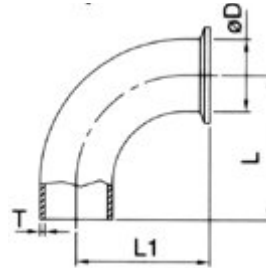

| SIZE | D | L | L1 | T |
|--------|-------|--------|--------|------|
| 1/2" | 12.7 | 76.20 | 41.15 | 1.65 |
| 3/4" | 19.05 | 76.20 | 41.15 | 1.65 |
| 1" | 25.4 | 76.20 | 50.80 | 1.65 |
| 1-1/2" | 38.1 | 95.25 | 69.85 | 1.65 |
| 2" | 50.8 | 120.65 | 88.90 | 1.65 |
| 2-1/2" | 63.5 | 139.70 | 107.95 | 1.65 |
| 3" | 76.2 | 158.75 | 127.00 | 1.65 |
| 4" | 101.6 | 203.20 | 168.15 | 2.10 |

BPE Short Outlet Reducing Tee Weld/ Clamp End (DT-14)

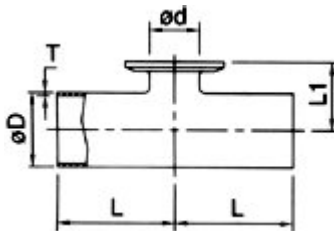

| SIZE | D | d | L | L1 | T |
|---------------|-------|-------|-------|------|------|
| 3/4" x 1/2" | 19.05 | 12.7 | 50.80 | 25.4 | 1.65 |
| 1" x 1/2" | 25.4 | 12.7 | 53.84 | 28.6 | 1.65 |
| 1" x 3/4" | 25.4 | 19.05 | 53.84 | 28.6 | 1.65 |
| 1-1/2" x 1/2" | 38.1 | 12.7 | 60.2 | 34.9 | 1.65 |
| 1-1/2" x 3/4" | 38.1 | 19.05 | 62.2 | 34.9 | 1.65 |
| 1-1/2" x 1" | 38.1 | 25.4 | 60.2 | 34.9 | 1.65 |
| 2" x 1/2" | 50.8 | 12.7 | 72.9 | 41.3 | 1.65 |
| 2" x 3/4" | 50.8 | 19.05 | 72.9 | 41.3 | 1.65 |
| 2" x 1" | 50.8 | 25.4 | 72.9 | 41.3 | 1.65 |
| 2" x 1-1/2" | 63.5 | 38.1 | 72.9 | 41.3 | 1.65 |
| 2-1/2" x 1/2" | 63.5 | 12.7 | 79.25 | 47.6 | 1.65 |
| 2-1/2" x 3/4" | 63.5 | 19.05 | 79.25 | 47.6 | 1.65 |
| 2-1/2" x 1" | 63.5 | 25.4 | 79.25 | 47.6 | 1.65 |

| SIZE | D | d | L | L1 | T |
|-----------------|-------|-------|-------|------|------|
| 2-1/2" x 1-1/2" | 63.5 | 38.1 | 79.4 | 47.6 | 1.65 |
| 2-1/2" x 2" | 63.5 | 50.8 | 79.4 | 47.6 | 1.65 |
| 3" x 1/2" | 76.2 | 12.7 | 85.7 | 54.0 | 1.65 |
| 3" x 3/4" | 76.2 | 19.05 | 85.7 | 54.0 | 1.65 |
| 3" x 1" | 76.2 | 25.4 | 85.7 | 54.0 | 1.65 |
| 3" x 1-1/2" | 76.2 | 38.1 | 85.7 | 54.0 | 1.65 |
| 3" x 2" | 76.2 | 50.8 | 85.7 | 54.0 | 1.65 |
| 3" x 2-1/2" | 76.2 | 63.5 | 85.7 | 54.0 | 1.65 |
| 4" x 1" | 101.6 | 25.4 | 104.8 | 66.7 | 2.10 |
| 4" x 1-1/2" | 101.6 | 38.1 | 104.8 | 66.7 | 2.10 |
| 4" x 2" | 101.6 | 50.8 | 104.8 | 66.7 | 2.10 |
| 4" x 2-1/2" | 101.6 | 63.5 | 104.8 | 66.7 | 2.10 |
| 4" x 3" | 101.6 | 76.2 | 104.8 | 66.7 | 2.10 |

BPE Fittings

BPE Instrument Tee Weld/ Clamp End (DT-28/29)

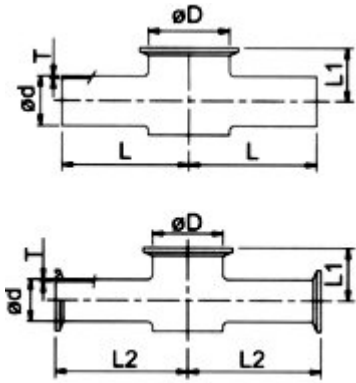

| SIZE | D | d | L | L1 | L2 | T |
|-----------------|------|-------|------|------|------|------|
| 1" x 1/2" | 25.4 | 12.7 | 63.5 | 22.2 | 77 | 1.65 |
| 1" x 3/4" | 25.4 | 19.05 | 63.5 | 25.4 | 77 | 1.65 |
| 1-1/2" x 1/2" | 38.1 | 12.7 | 63.5 | 22.2 | 76.2 | 1.65 |
| 1-1/2" x 3/4" | 38.1 | 19.05 | 63.5 | 25.4 | 76.2 | 1.65 |
| 1-1/2" x 1" | 38.1 | 25.4 | 63.5 | 28.6 | 76.2 | 1.65 |
| 2" x 1/2" | 50.8 | 12.7 | 69.9 | 25.4 | 82.6 | 1.65 |
| 2" x 3/4" | 50.8 | 19.05 | 69.9 | 28.6 | 82.6 | 1.65 |
| 2" x 1" | 50.8 | 25.4 | 69.9 | 31.8 | 82.6 | 1.65 |
| 2" x 1-1/2" | 50.8 | 38.1 | 69.9 | 38.1 | 82.6 | 1.65 |
| 2-1/2" x 1/2" | 63.5 | 12.7 | 85.0 | 35.0 | 97.0 | 1.65 |
| 2-1/2" x 3/4" | 63.5 | 19.05 | 85.0 | 38.6 | 97.0 | 1.65 |
| 2-1/2" x 1" | 63.5 | 25.4 | 85.0 | 41.3 | 97.0 | 1.65 |
| 2-1/2" x 1-1/2" | 63.5 | 38.1 | 85.0 | 44.5 | 97.0 | 1.65 |
| 2-1/2" x 2" | 63.5 | 50.8 | 85.0 | 48.0 | 97.0 | 1.65 |

| SIZE | D | d | L | L1 | L2 | T |
|-------------|-------|-------|-----|-------|-----|------|
| 3" x 1/2" | 76.2 | 12.7 | 90 | 38.1 | 102 | 1.65 |
| 3" x 3/4" | 76.2 | 19.05 | 90 | 41.3 | 102 | 1.65 |
| 3" x 1" | 76.2 | 25.4 | 90 | 44.5 | 102 | 1.65 |
| 3" x 1-1/2" | 76.2 | 38.1 | 90 | 48.0 | 102 | 1.65 |
| 3" x 2" | 76.2 | 50.8 | 90 | 50.8 | 102 | 1.65 |
| 3" x 2-1/2" | 76.2 | 63.5 | 90 | 54.0 | 102 | 1.65 |
| 4" x 1/2" | 101.6 | 12.7 | 110 | 79.4 | 122 | 1.65 |
| 4" x 3/4" | 101.6 | 19.05 | 110 | 82.6 | 122 | 1.65 |
| 4" x 1" | 101.6 | 25.4 | 110 | 85.7 | 122 | 1.65 |
| 4" x 1-1/2" | 101.6 | 38.1 | 110 | 88.7 | 122 | 1.65 |
| 4" x 2" | 101.6 | 50.8 | 110 | 95.2 | 122 | 1.65 |
| 4" x 2-1/2" | 101.6 | 63.5 | 110 | 98.4 | 122 | 1.65 |
| 4" x 3" | 101.6 | 76.2 | 110 | 101.6 | 122 | 1.65 |

BPE Concentric and Eccentric Reducer Weld/ Clamp End (DT-26)

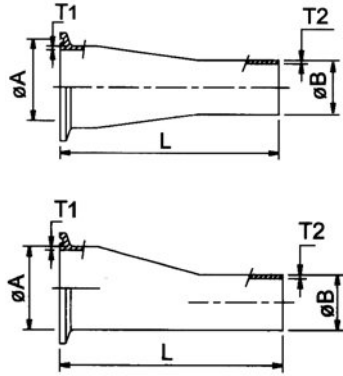

| SIZE | A | B | L | T1 | T2 |
|---------------|-------|-------|-------|------|------|
| 3/4" x 1/2" | 19.05 | 12.7 | 76.2 | 1.65 | 1.65 |
| 1" x 1/2" | 25.4 | 12.7 | 88.9 | 1.65 | 1.65 |
| 1" x 3/4" | 25.4 | 19.05 | 76.2 | 1.65 | 1.65 |
| 1-1/2" x 1/2" | 38.1 | 12.7 | 114.3 | 1.65 | 1.65 |
| 1-1/2" x 3/4" | 38.1 | 19.05 | 101.6 | 1.65 | 1.65 |
| 1-1/2" x 1" | 38.1 | 25.4 | 101.6 | 1.65 | 1.65 |
| 2" x 1/2" | 50.8 | 12.7 | 165.4 | 1.65 | 1.65 |
| 2" x 3/4" | 50.8 | 19.05 | 152.4 | 1.65 | 1.65 |
| 2" x 1" | 50.8 | 25.4 | 152.4 | 1.65 | 1.65 |
| 2" x 1-1/2" | 50.8 | 38.1 | 101.6 | 1.65 | 1.65 |

| SIZE | A | B | L | T1 | T2 |
|-----------------|-------|------|-------|------|------|
| 2-1/2" x 1-1/2" | 63.5 | 38.1 | 152.4 | 1.65 | 1.65 |
| 2-1/2" x 2" | 63.5 | 50.8 | 108.0 | 1.65 | 1.65 |
| 3" x 1-1/2" | 76.2 | 38.1 | 203.2 | 1.65 | 1.65 |
| 3" x 2" | 76.2 | 50.8 | 158.8 | 1.65 | 1.65 |
| 3" x 2-1/2" | 76.2 | 63.5 | 108.0 | 1.65 | 1.65 |
| 4" x 1-1/2" | 101.6 | 38.1 | 308.0 | 2.10 | 1.65 |
| 4" x 2" | 101.6 | 50.8 | 263.5 | 2.10 | 1.65 |
| 4" x 2-1/2" | 101.6 | 63.5 | 212.7 | 2.10 | 1.65 |
| 4" x 3" | 101.6 | 76.2 | 161.9 | 2.10 | 1.65 |

BPE Short Outlet Run Tee Weld/ Clamp End (DT-25)

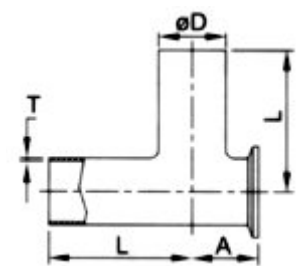

| SIZE | D | A | L | T |
|--------|-------|------|-------|------|
| 1/2" | 12.7 | 22.2 | 47.6 | 1.65 |
| 3/4" | 19.05 | 25.4 | 50.8 | 1.65 |
| 1" | 25.4 | 28.6 | 54.0 | 1.65 |
| 1-1/2" | 38.1 | 34.9 | 60.3 | 1.65 |
| 2" | 50.8 | 41.3 | 73.0 | 1.65 |
| 2-1/2" | 63.5 | 47.6 | 79.4 | 1.65 |
| 3" | 76.2 | 54.0 | 85.7 | 1.65 |
| 4" | 101.6 | 69.9 | 104.8 | 2.10 |