

Three-piece ball valve featuring a unique design for easy and fast maintenance.

Features

- Forged body and connectors.
- Designed to international and European standards.
- Suitable for ON-OFF and control service.
- ISO 5211 top plate flange allows the mounting of 1/4 turn actuators without removing the valve body.
- Antistatic device to ISO 7121 and BS-5351.
- Guided blow-out proof stem.
- Fully adjustable packing gland.
- Fugitive emission free packing-TA-LUFT certified available upon request.
- Tightness to ISO 5208: Cat. A bubble tight.
- Standard DIN 50049-3.1.B certificate available.
- Modular "V16 SYSTEM" for check valve, strainer, sight-glass.
- A wide range of seating materials available. (PTFE, TFM, PVG, PEEK, etc.).
- Large range of options and special applications (3-way valves, tank bottom valve, cryogenic application, dead volume free design, very high temperature operation, etc.).
- Various agreements and certifications.
- Manufactured by an ISO 9000 certified production unit.

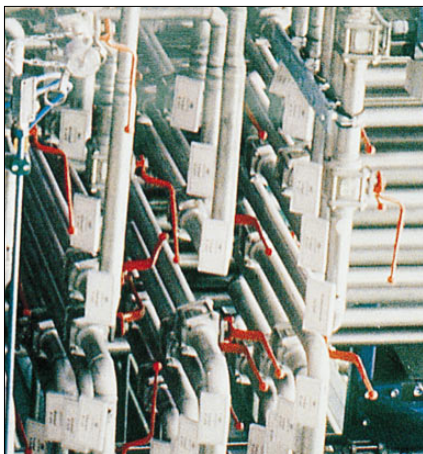

Applications

- Perfect valve for heavy duty working conditions in chemical corrosive fluids.
- Liquids, steam, gas and oil for process and utilities.
- Whenever safety and reliability are important issues.

Technical data

Sizes (mm)	: 8 - 150
Temperature (°C)	: -60 to +225
Pressure (bar)	: PN10 - PN 100
Connections	: butt weld ends, socket weld ends, threaded ends BSPP and NPT, screwed on flanges face to face dimension to ISO 5752 series 1 and EN 558-1, special connections on request.

Ball Valve Type V16

materials full bore / DN 8 to DN 50

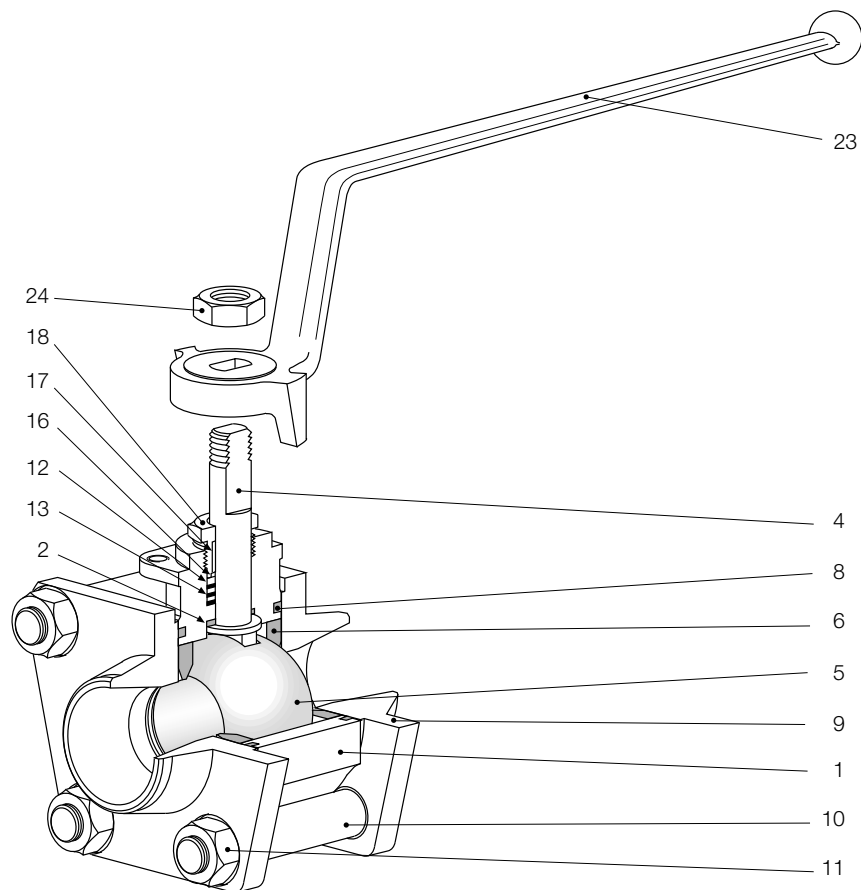

Antistatic device

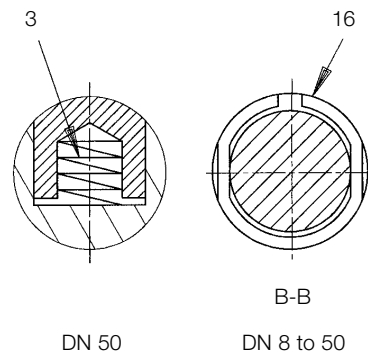

Packing and anti blow-out stem

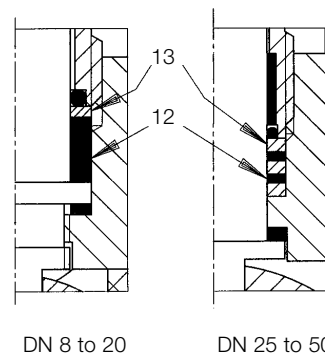

Parts list

Item	Qty	Description	Material	
1	1	Body	ASTM A 182-F 316L (forged)	
2	1	Friction washer	PTFE	
3	1	Antistatic spring DN 50	AISI 316	
4	1	Stem	AISI 316L	
5	1	Ball	AISI 316L	
6	2	Seat DN 10 to DN 40 DN 50	PTFE/Glass PTFE	*1
7	2	Seat support DN 50	AISI 316L	
8	2	Body gasket	PTFE	*1
9	2	Flanged end connector		
9A	2	End connector	ASTM A182-F 316L (forged)	
9B	2	Flange support	AISI 316L	
10	4	Tie bolt	A 2-70 ISO 3506	
11	8	Nut	AISI 304	
12	1/2	Soft gland washer	PTFE	*1/*2
13	1/3	Metallic gland washer	AISI 316L	*2
15	2	Gland stud DN 50	AISI 316L	
16	1	Spring wire	AISI 316	
17	1	Gland ring DN 25 to DN 50	PTFE	
18	1	Gland	AISI 316L	
19	2	Gland nut DN 50	AISI 304	
20	1	Stop screw DN 08 to DN 40	AISI 304	
21	1	Travel stop DN 50	AISI 304	
22	2	Stop screw DN 50	AISI 304	
23	1	Lever	Malleable iron	
24	1	Screw	ANSI 304	
25	2	Flange	AFNOR A 37 (forged)	*1

All indicated material are equivalent standard designations.

* 1) Other materials upon request

* 2) x/. for DN 08 to DN 20 FB
.y for DN 25 to DN 50 FB.

Metal seat support for DN 50

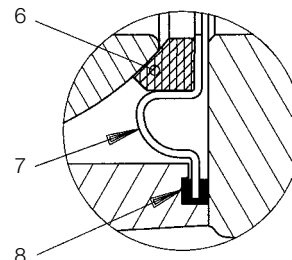

Bolted gland for DN 50

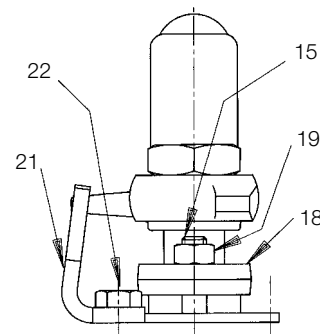

Ball Valve Type V16

dimensions full bore / DN 8 to DN 50

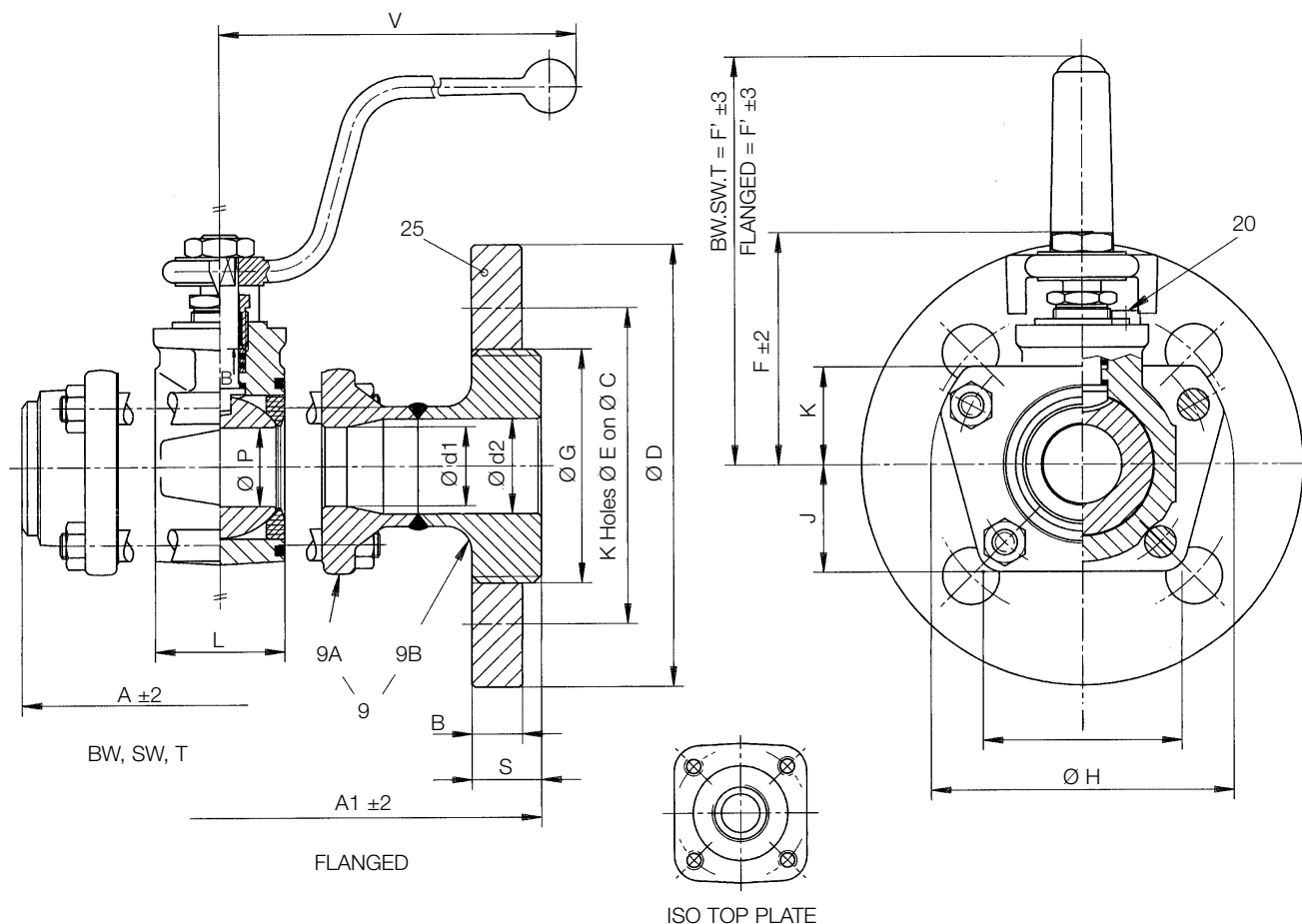

Valve dimensions (mm)

DN	ISO	A	A1	B	C	d1	d2	D	E	F	F'	F''	G	H	I	J	K	L	P	S	V	Weight (Kg)	
																						Flanged	BW
08	F03	65				8				57	77	109		64	38	21.5	18.5	22	11		160		0.67
10/12	F03	65	130	14	60	11	11	90	14	57	77	109	M42x2.5	64	38	21.5	18.5	22	11	18	160	1.8	0.67
15	F03	70	130	14	65	14	16	95	14	60	80	112	M48x2.5	73	44	23.5	20.5	25	14	20	160	2.7	0.88
20	F04	85	150	16	75	18	20	105	14	70	123	123	M58x2.5	86	55	30	25.5	31	17	20	210	4.2	1.64
25	F04	100	160	16	85	25	25	115	14	72	127	127	M65x2.5	96	63	34	31	41	25	20	210	5.5	2.3
32	F05	110	180	16	100	30	30	140	18	81	132	132	M74x2.5	111	68	36	34.5	48	30	22	210	6	3
40	F05	125	200	16	110	40	40	150	18	97	140	140	M85x2.5	131	83	44	42.5	60	40	22	260	9.6	4.8
50	F07	150	230	18	125	50	51	165	18	119	161	161	M95x2.5	166	102	53	54.5	75	50	22	315	12	8.5

Note: Standard carbon steel screwed-on flanges to PN16, Ra 6.3 facing.

On request: carbon steel screwed-on flanges ANSI 150, ANSI 300, PN 25 PN 40 or stainless steel screwed-on flanges PN 16 to PN 40, ANSI 150 and 300.

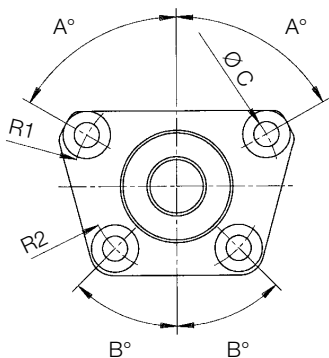

V-shaped connectors dimensions

DN	A°	R1	B°	R2	C
8	60	24.7	45	20.2	6.5
10/12	60	24.7	45	20.2	6.5
15	60	27.6	45	23.3	6.5
20	60	35	45	29.5	8.5
25	62	39.9	45	34.9	8.5
32	60	47	45	39	8.5
40	62	54.8	45	47.8	10.5
50	55	71.5	45	58	12.5

The V-shaped connectors feature the easiest and fastest maintenance.

Ball Valve Type V16

end connections and ratings full bore / DN 8 to DN 50

End connections SW, T, BW

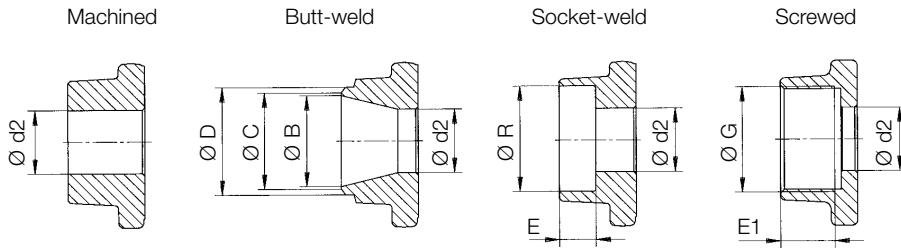

Notes

All the end connections are machined from the basic unmachined forged connectors. This technology allows quick response to the customers demand and a large variety of special connections.

End connections - main dimensions mm

V16 Type DN	Unmachined H d 2	Butt-weld			Socket-Weld		Screwed			
		T	C	D	F	R	BSP		NPT	
							B	E	G	E 1
8	8	8	10	13.5	9.5	13.7	1/4"	11	1/4"	10.5
10	11						3/8"	11.5	3/8"	10.
12	11	11	13.5	17.5	9.5	17.5	3/8"	11.5	3/8"	10.5
15	14	16	17	21.3	9.5	21.6	1/2"	15	1/2"	13.5
20	18	21.6	23	26.9	11	27.2	3/4"	16.5	3/4"	14
25	25	27.2	30	33.7	12.5	34	1"	19	1"	17.5
32	30	35.9	39	42.4	14.5	42.8	1 1/4"	21.5	1 1/4"	18
40	40	41.8	45	48.3	16	48.8	1 1/2"	21.5	1 1/2"	18.5
50	50	53	56	60.3	17.5	60.8	2"	26	2"	19.5

Pressure - temperature rating

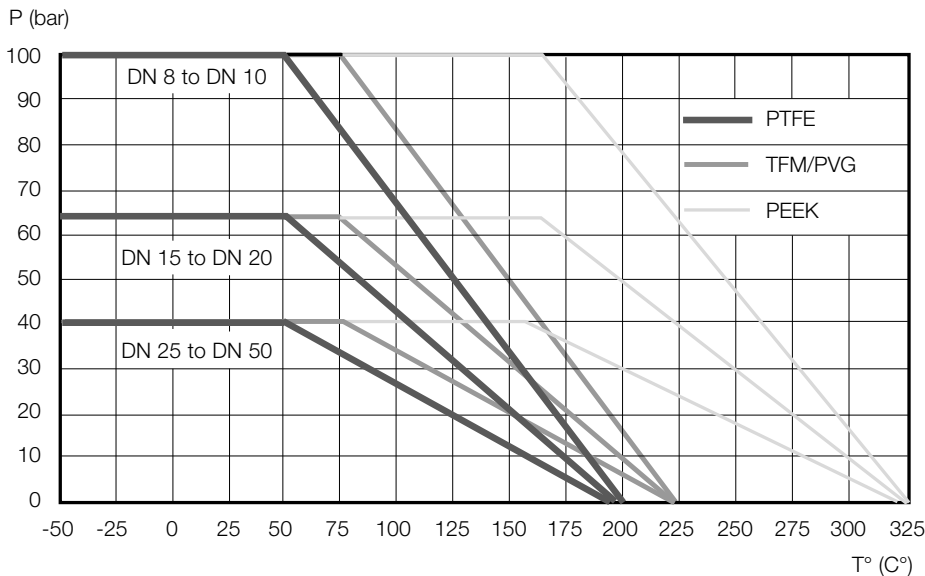

Standard packing and body gasket

- $T^\circ < 200^\circ\text{C}$
Packing : PTFE
Gasket : PTFE
- $T^\circ \geq 200^\circ\text{C}$
Packing : Graphite
Gasket : Stainless steel reinforced PTFE ($\leq 250^\circ\text{C}$) or graphite.
- Other packing and gasket materials upon request

Notes

Standards seats:

- 25% glass reinforced PTFE DN 8 to DN 40. PTFE : DN 50.

Optional seats:

- TFM/PVG (carbon reinforced PTFE)
 - PEEK (carbon reinforced)
- Other seat materials (on request):
- PE Cryogenic and nuclear application
 - Expanded graphite - high temperature applications
- Other seat designs (on request):
Pressure relieving seats: TFM and PVG

Flow coefficient Cv/Kv

Welded or screwed ends

DN	12	15	20	25	32	40	50
Cv	23	29	32	94	112	245	455
Kv	20	25	27	81	96	211	392

Flanged (to NFE 29-312)

DN	15	20	25	32	40	50
Cv	26	30	71	96	210	354
Kv	22	26	61	83	181	305

Ball Valve Type V16

brackets and coupling full bore / DN 8 to DN 50

Testing

- All our valves are standard tested according to the Gachot quality assurance manual:
 - 100% for the flanged and threaded valves,
 - 10% for the welded end valves.

Acceptance criteria

NFE-29311 - ISO 5208 - DIN 3230

- Hydrostatic shell test: 1.5 x Pressure rating (ambient temperature).
No visible leakage.
- Air seat test: 6 bar air (air in the valve body). No bubbles accepted.

Modular system

Between the same flanges can be mounted:

- V16 check valve
- V16 strainer
- V16 sight glass
- V16 3-way valve (L or T port)

Options

- Heating jacketed V16
- Limit switch kit
- Tank bottom V16 valve
- Cryogenic V16
- Other connections and levers
- Padlocking kit

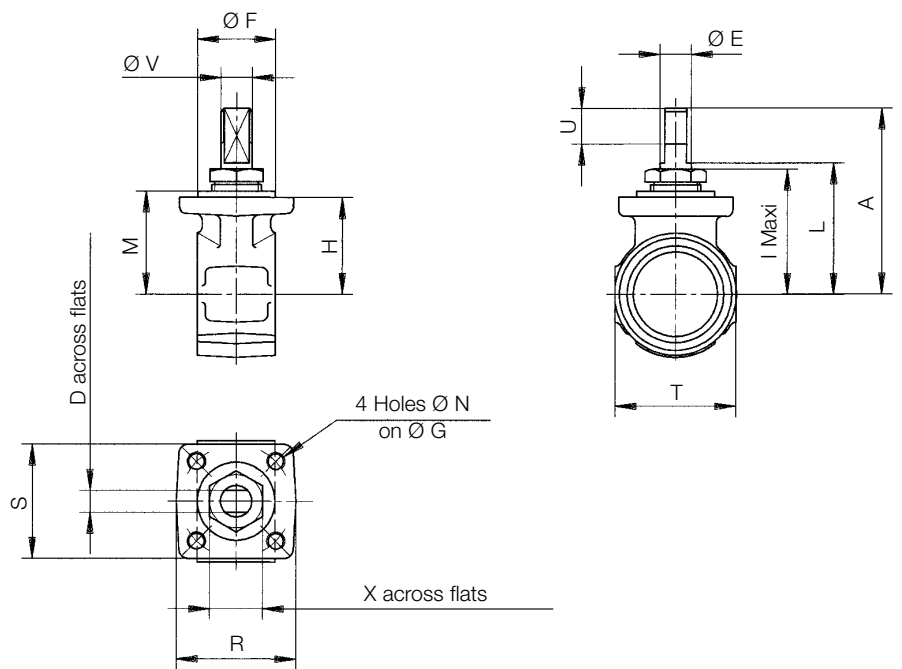

Dimensions for bracket and coupling

DN	ISO	A	D	E	F	G	H	I	L	M	N	R	S	T	U	V	X
8	F03	57	7	10.1	25	36	28.5	38.5	39.5	30.5	M6	36.5	36.5	32.8	11	M10	17
10	F03	57	7	10.1	25	36	28.5	38.5	39.5	30.5	M6	36.5	36.5	32.8	11	M10	17
12	F03	57	7	10.1	25	36	28.5	38.5	39.5	30.5	M6	36.5	36.5	32.8	11	M10	17
15	F03	59.5	7	10.1	25	36	31	41	42	33	M6	36.5	36.5	38.8	11	M10	17
20	F04	69.5	7	12.1	30	42	38.5	48.5	51.5	40.5	M6	42	42	48.6	11	M12	19
25	F04	72	7	12.1	30	42	44	54.5	56	46	M6	42	42	59.2	9	M12	19
32	F05	81	7	13.8	35	50	50.5	62	64	53.5	M6	50	50	69	10	M14	24
40	F05	96.5	7	15.8	35	50	63	75.5	76.5	66	M6	50	50	82.8	12	M16	30
50	F07	118.5	12	19.75	55	70	60.5	81	90.5	63.5	M8	67	71.5	101.5	16	M20	/

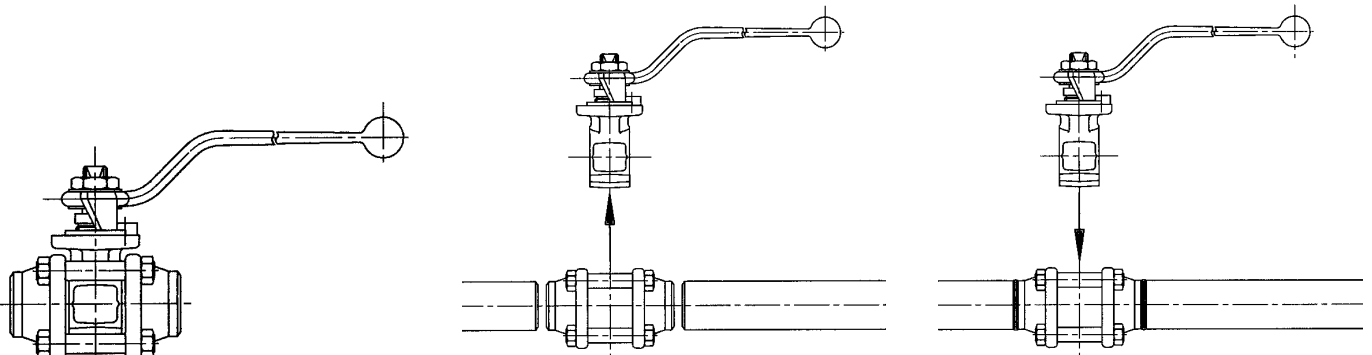

Welded connections V16 - Piping installation

- When the ball valve body has been removed (by just loosening the bolt nuts), the flanges set up a rigid cage easy to weld.
- Once the welding is finished, just pull the two flanges apart, insert the body between the flanges and tighten back the nuts.
- The V16 is ready to operate.

Ball Valve Type V16

actuator selection full bore / DN 8 to DN 50

Torque values for standard seats/Nm

DN	ΔP	Standard seats			Pressure relieving seats			Stem limiting torque (Nm)
		7	16	25	7	16	25	
08		8	9	12	8	9	12	45
15		9	10	15	9	10	15	45
20		10	12	16	10	12	16	66
25		14	17	20	14	17	20	66
32		20	25	30	20	25	30	94
40		35	40	45	30	38	45	138
50		40	50	65	35	45	65	309

Torques measured with water 1cPo viscosity at 20°C

Other seats: TFM/Carbon PTFE: +20%; PEEK DN 8 to 32: +40%, DN 40 to 50: +30%

Other packing gland: graphite packing: +10%

Actuation and control

Actuation

- Pneumatic double acting and single acting actuators.
- Electric actuators. Double acting and single acting spring return.
- Electric actuators for special applications.

Control

- Various control devices (spool valves, limit switch box).
- Pneumatic, electro-pneumatic and intelligent positioners.

Selection of pneumatic actuators series 79/D for standard seats

DN	Air supply (bar)	Double Acting Actuator ΔP (bar)				Single Acting Actuator ΔP (bar)			
		7	16	25	50	7	16	25	50
Application I									
8	4	003	003	003	003	006S-2.7	006S-2.7	006S-2.7	012S-2.7
	6	003	003	003	003	003S-5.5	003S-5.5	006S-3.4	006S-5.5
	8	003	003	003	003	003S-5.5	003S-5.5	003S-6.9	006S-5.5
10	4	003	003	003	003	006S-2.7	006S-2.7	006S-2.7	012S-2.7
	6	003	003	003	003	003S-5.5	003S-5.5	006S-3.4	006S-5.5
	8	003	003	003	003	003S-5.5	003S-5.5	003S-6.9	006S-5.5
15	4	003	003	003	006	006S-2.7	006S-2.7	012S-2.7	012S-2.7
	6	003	003	003	003	003S-5.5	003S-5.5	006S-5.5	006S-5.5
	8	003	003	003	003	003S-5.5	003S-5.5	006S-5.5	006S-5.5
20	4	003	003	003	006	006S-2.7	006S-2.7	012S-2.7	012S-3.4
	6	003	003	003	003	003S-5.5	006S-3.4	006S-5.5	012S-3.4
	8	003	003	003	003	003S-5.5	003S-6.9	006S-5.5	006S-6.9
25	4	003	003	006	006	012S-2.7	012S-2.7	012S-3.4	024S-2.7
	6	003	003	003	003	006S-3.4	006S-5.5	006S-5.5	012S-4.1
	8	003	003	003	003	006S-3.4	006S-5.5	006S-5.5	012S-4.1
32	4	006	006	006	012	012S-3.4	012S-2.7	024S-2.7	024S-2.7
	6	003	003	006	006	006S-5.5	012S-2.7	012S-4.1	012S-5.5
	8	003	003	003	006	006S-5.5	006S-6.9	012S-4.1	012S-5.5
40	4	006	012	012	012	024S-2.7	024S-2.7	024S-3.4	036S-3.4
	6	006	006	006	012	012S-5.5	012S-5.5	024S-3.4	024S-4.1
	8	003	006	006	006	012S-5.5	012S-5.5	012S-6.9	024S-4.1
50	4	012	012	012	024	024S-2.7	024S-3.4	036S-3.4	065S-2.7
	6	006	006	012	012	012S-5.5	024S-3.4	024S-4.1	036S-5.5
	8	006	006	006	012	012S-5.5	012S-6.9	024S-4.1	024S-6.9
Application II									
8	4	003	003	003	006	006S-2.7	006S-2.7	012S-2.7	012S-2.7
	6	003	003	003	003	003S-5.5	006S-2.7	006S-5.5	006S-5.5
	8	003	003	003	003	003S-5.5	003S-6.9	006S-5.5	006S-5.5
10	4	003	003	003	006	006S-2.7	006S-2.7	012S-2.7	012S-2.7
	6	003	003	003	003	003S-5.5	006S-2.7	006S-5.5	006S-5.5
	8	003	003	003	003	003S-5.5	003S-6.9	006S-5.5	006S-5.5
15	4	003	003	003	006	006S-2.7	006S-2.7	012S-2.7	012S-2.7
	6	003	003	003	003	006S-2.7	006S-3.4	006S-5.5	012S-2.7
	8	003	003	003	003	003S-6.9	003S-6.9	006S-5.5	006S-6.9
20	4	003	003	003	006	006S-2.7	012S-2.7	012S-2.7	024S-2.7
	6	003	003	003	003	006S-3.4	006S-5.5	006S-5.5	012S-4.1
	8	003	003	003	003	003S-6.9	006S-5.5	006S-5.5	006S-8.2
25	4	003	006	006	006	012S-2.7	012S-3.4	012S-3.4	024S-2.7
	6	003	003	003	006	006S-5.5	006S-5.5	012S-3.4	012S-5.5
	8	003	003	003	003	006S-5.5	006S-5.5	006S-6.9	012S-5.5
32	4	006	006	006	012	012S-3.4	024S-2.7	024S-2.7	024S-3.4
	6	003	006	006	006	012S-3.4	012S-4.1	012S-5.5	024S-3.4
	8	003	003	003	006	006S-6.9	012S-4.1	012S-5.5	012S-6.9
40	4	012	012	012	012	024S-3.4	024S-3.4	036S-3.4	065S-2.7
	6	006	006	006	012	012S-5.5	024S-3.4	024S-4.1	036S-4.2
	8	006	006	006	006	012S-5.5	012S-6.9	012S-6.9	024S-5.5
50	4	012	012	024	024	024S-3.4	036S-3.4	065S-2.7	065S-2.7
	6	006	012	012	024	024S-3.4	024S-4.1	036S-4.2	065S-2.7
	8	006	006	012	012	012S-6.9	024S-4.1	024S-5.5	036S-6.9

Notes

Application I: Water and low viscosity liquids, temperature 20°C to 120°C standard service. Seat material DN 10 to 40: PTFE + 25% glass, DN 50: PTFE.

Application II: Dry fluids, high viscosity liquids, steam, oxygen service, heavy duty service, high temperature service > 120°C.

Seat material DN 10 to 40: PTFE + 25% glass, DN 50: PTFE

Stem guide design for DN 150

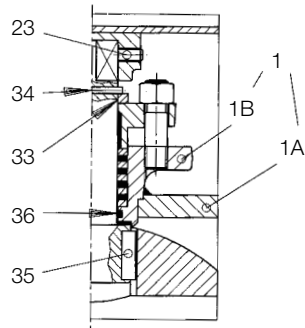

Lower shaft for DN 150

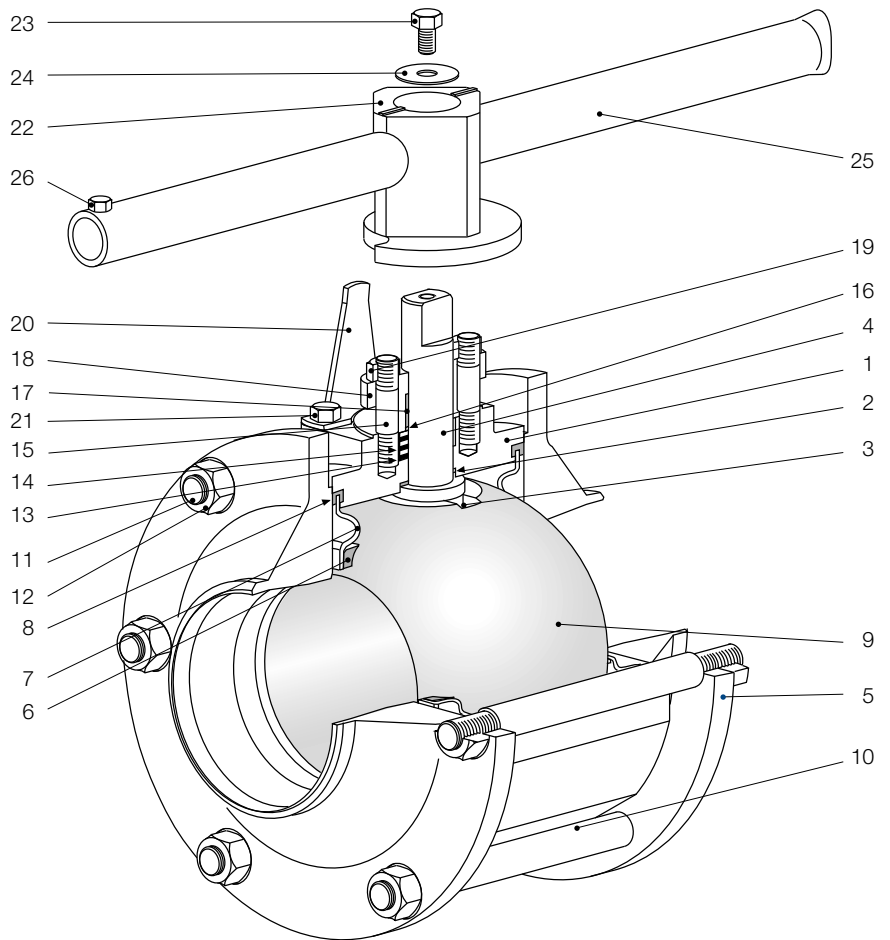
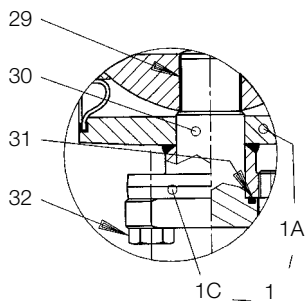

Parts list

Item Qty	Description	Material
1 1	Body	
1A 1	Body	ASTM A 182-F 316L (forged)
1B 1	Gland support DN 150	AISI 316L
1C 1	Ball guide support DN 150	AISI 316L
2 1	Friction washer	PTFE
3 1	Antistatic spring DN 65 to DN 100	AISI 316
4 1	Stem	AISI 316L
5 1	Ball	AISI 316L (forged)
6 2	Seat	PTFE *1
7 2	Seat support	AISI 316L
8 2	Body gasket	PTFE *1
9 2	Flanged end connector	
9A 2	End connector	ASTM A 182-F 316L (forged)
9B 2	Flange support	AISI 316L
10 4	Shouldered tie bolt	A 2-70 ISO 3506
11 2/4	Tie bolt	A 2-70 ISO 3506 *2
12 12/16	Nut	AISI 304 *2
13 3/4	Soft gland washer	PTFE *1 *2
14 4/5	Metallic gland washer	AISI 316L *2
15 2	Gland stud	AISI 316L
16 1	Spring wire DN 65 to DN 100	AISI 316
17 1	Gland ring	PTFE
18 1	Gland	AISI 316L
19 2	Gland nut	AISI 304
20 1	Travel stop DN 65 to DN 100 DN 150	AISI 304 AFNOR E24-2

Item Qty	Description	Material
21 2	Stop screw DN 65 to DN 100 DN 150	AISI 304 Steel
22 1	Lever cap	Malleable iron
23 1	Screw lever	Cadmium plated steel
24 1	Washer DN 65 to DN 100	Cadmium plated steel
25 1	Lever	Steel
26 1	Screw DN 65 to DN 100	Cadmium plated steel
27 2	Flange	AFNOR A 37 (forged)
28 2	Stop washer DN 150	AISI 316L
29 1	Guide ball ring DN 150	PTFE
30 1	Ball guide DN 150	AISI 316L
31 1	Gasket DN 150	PTFE
32 2	Screw DN 150	AISI 304
33 1	Washer DN 150	AISI 316L
34 1	Pin DN 150	AISI 302/304
35 1	Key DN 150	AISI 316L
36 1	Gasket DN 150	Viton

All indicated material are equivalent standard designations.

* 1) Other materials upon request

* 3) x/. for DN 65 to DN 100
.y for DN 150

Ball Valve Type V16

dimensions full bore / DN 65 to DN 150

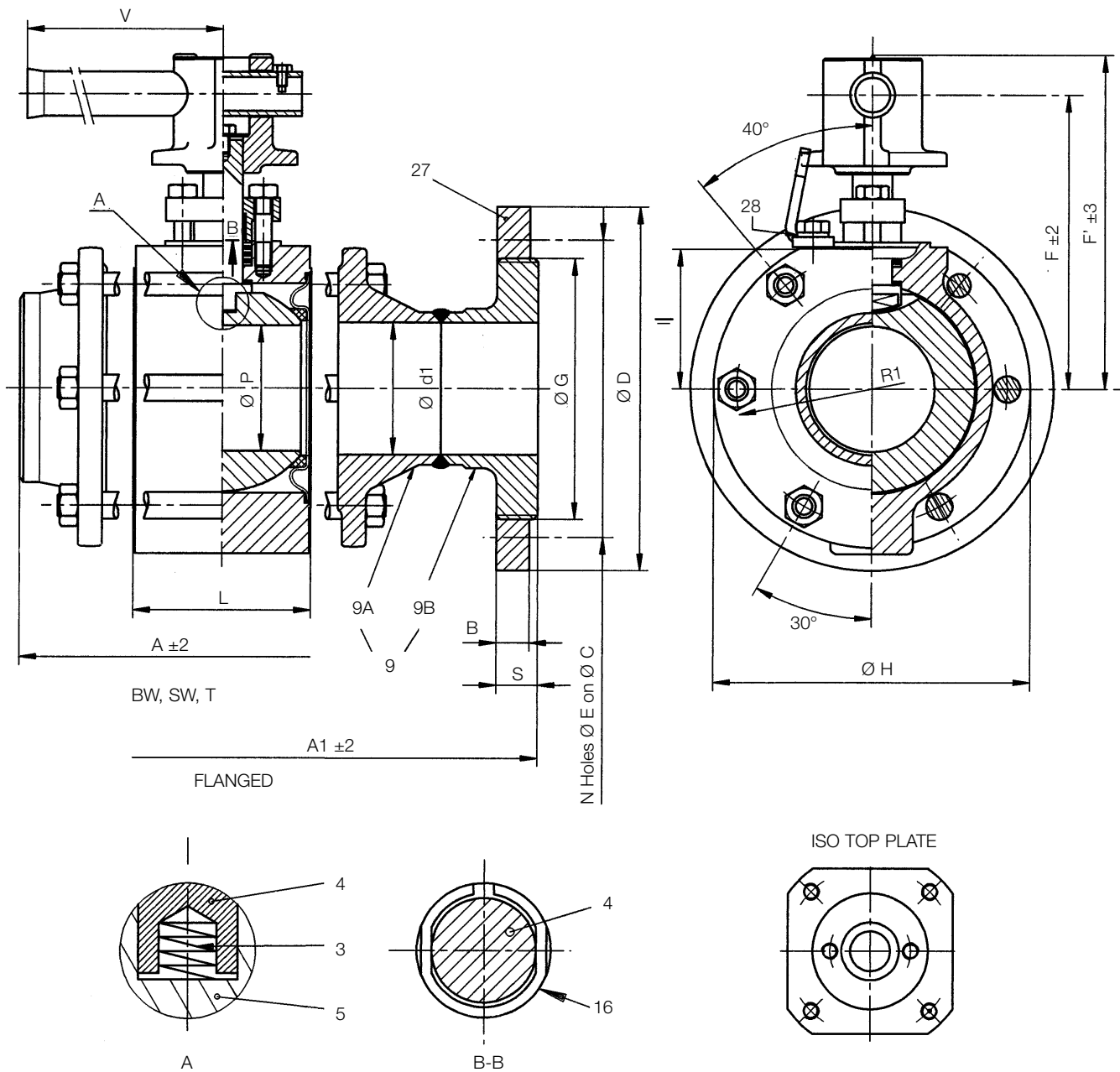

Valve dimensions (mm)

DN	ISO	A	A1	B	C	D	d1	E	F	F'	G	H	I	L	N	P	R1	S	V	Weight (Kg)	
																				Flanged	BW
65	F10	180	290	18	145	185	65	18	173	197	M119 x 2.5	175	80	100	4	65	75.5	22	500	16.19	26
80	F10	210	310	20	160	200	80	18	178	202	M130 x 2.5	192	85	107.5	8	76	82	23	500	21	30.5
100	F10	244	350	20	180	220	100	18	199	223	M158 x 3	246	/	134.5	8	101	107.5	25	500	49.5	39.5
150	F12	419	480	22	240	285	150	22	253	287	M212 x 3	340	/	193	8	150	150	25	1170		

Note: standard carbon steel screwed-on flanges to PN16, Ra 6.3 facing.

On request: carbon steel screwed-on flanges ANSI 150, ANSI 300, PN 25 PN 40 or stainless steel screwed-on flanges PN 16 to PN 40, ANSI 150 and 300.

Ball Valve Type V16

end connections and ratings full bore / DN 65 to DN 150

Notes

All the end connections are machined from the basic unmachined forged connectors. This technology allows quick response to the customers demand and a large variety of special connections.

End connections SW, T, BW

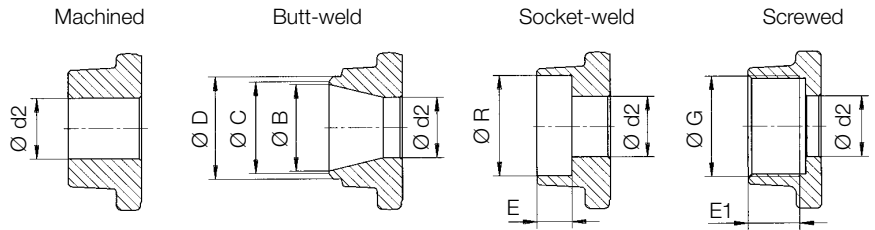

End connections - main dimensions mm

V16 Type DN	Unmachined H d 2	Butt-weld			Socket-Weld		Screwed		NPT	
		T			F	R	BSP	E 1	G	E1
		B	C	D	E		G		G	E1
65	65	68.8	72	76.1	19	76.6	2" 1/2	30.5	2" 1/2	29
80	80	82.5	84.5	88.9	20.5	89.5	3"	33.5	3"	30.5
100	100	105.3	107.5	114.3	20.5	114.9	4"	39	4"	33
150	150	159.3	161.5	168.3	20.5	168.9				

Standard packing and body gasket

- T° < 200°C
Packing : PTFE
Gasket : PTFE
- T° ≥ 200°C
Packing : Graphite
Gasket : Stainless steel reinforced PTFE (≤ 250°C) or graphite.
- Other packing and gasket materials upon request

Pressure - temperature rating

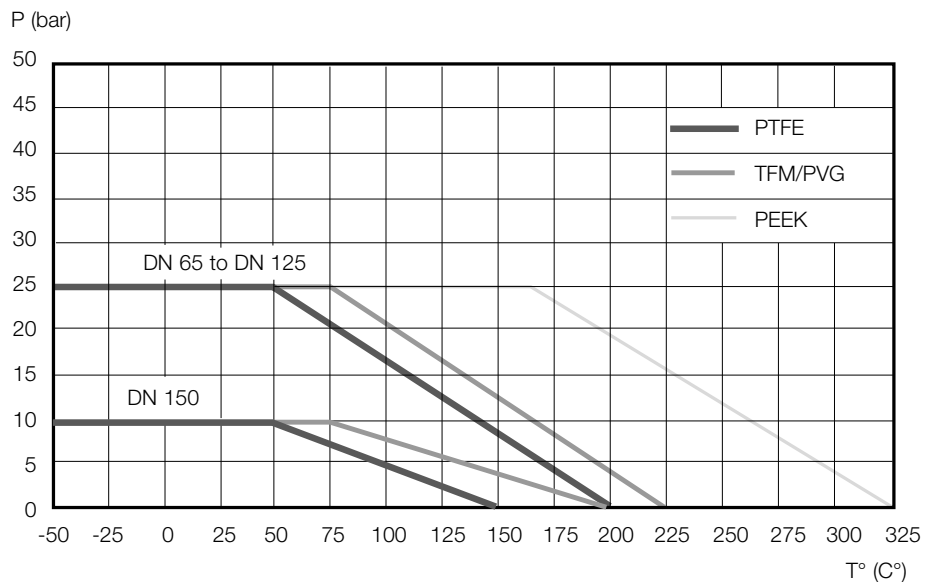

Flow coefficient Cv/Kv

Welded or screwed ends

DN	65	80	100
Cv	795	1350	2350
Kv	685	1164	2026

Flanged (to NFE 29-312)

DN	65	80	100
Cv	785	1560	2716
Kv	677	1345	2340

Notes

Standards seats:

- PTFE

Optional seats:

- TFM/PVG (carbon reinforced PTFE)
- PEEK (carbon reinforced)
- Other seat materials (on request):
- PE Cryogenic and nuclear application
- Expanded graphite - high temperature applications

Other seat design (on request):

Pressure relieving seats: TFM and PVG

Ball Valve Type V16

brackets and coupling full bore / DN 65 to DN 150

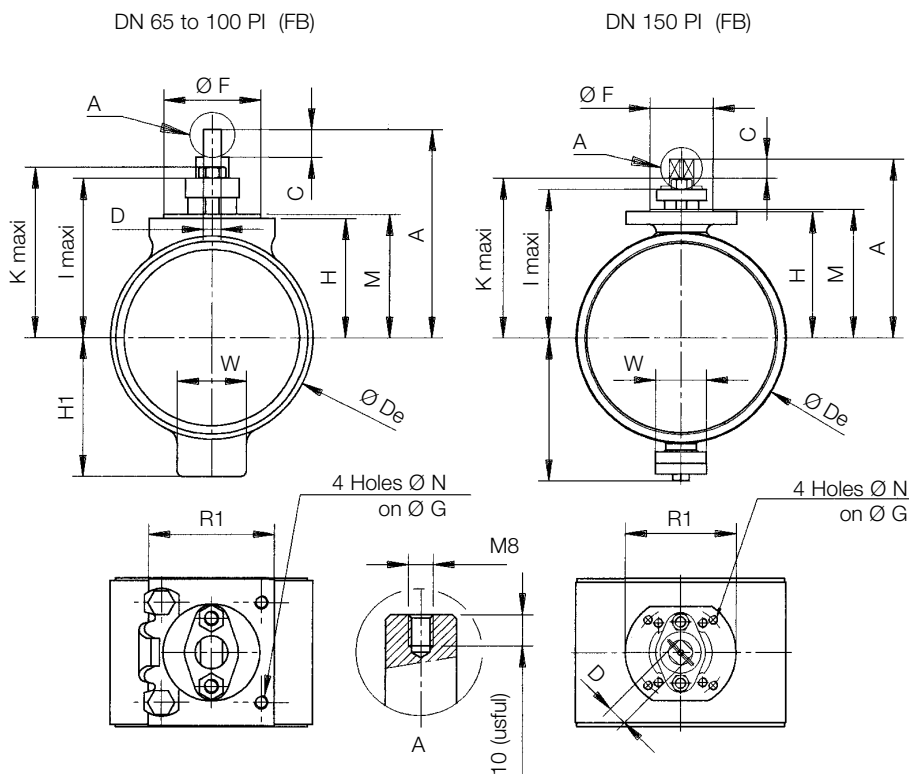

Dimensions for bracket and coupling

DN	ISO	A	C	D	De	F	G	H	H1	I	K	M	N	R1	W
65	F10	145	20	16	135.5	70	102	82.5	90	112	121	85.5	M10	99	50
80	F10	150	20	16	146.5	70	102	86	100	116	125	89	M10	106.5	50
100	F10	170.5	20	16	190.5	70	102	108	115	137	146	111	M10	133.5	75
150	F12	233	25	26	275	85	125	165	186	194	208	168	M12	150	65

Testing

- All our valves are standard tested according to the Gachot quality assurance manual: 100% for the flanged and threaded valves, 10% for the welded end valves.

Acceptance criteria

- According to:
NFE-29311 - ISO 5208 - DIN 3230
- Hydrostatic shell test: 1.5 x Pressure rating (ambient temperature). No visible leakage.
 - Air seat test: 6 bar air (air in the valve body). No bubbles accepted.

Modular system

Between the same flanges can be mounted:

- V16 check valve
- V16 strainer
- V16 sight glass
- V16 3-way valve (L or T port)

Options

- Heating jacketed V16
- Limit switch kit
- Tank bottom V16 valve
- Cryogenic V16
- Other connections and levers
- Padlocking kit

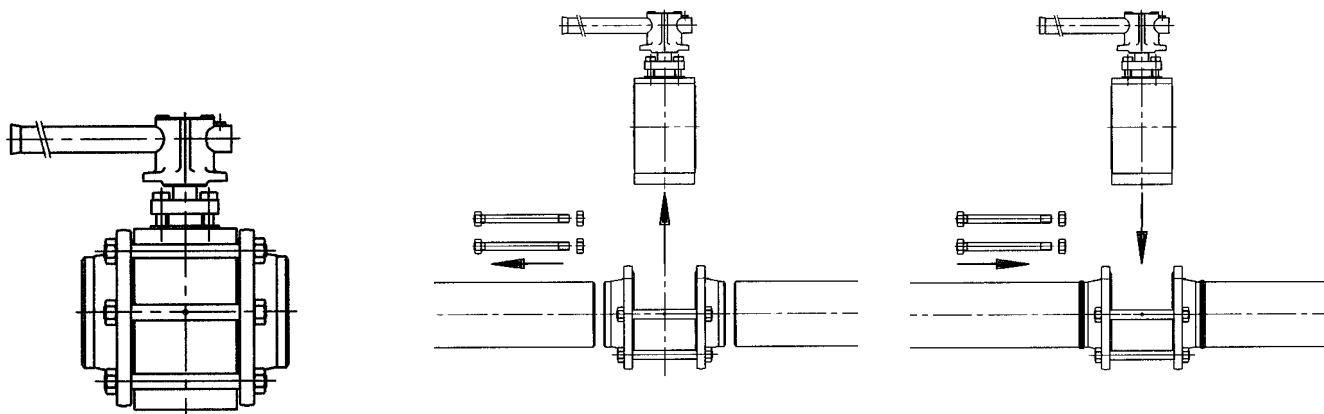

Welded connections V16 - Piping installation

- When the ball valve body has been removed (by just loosening the bolt nuts and removing the two upper stud bolts or the four upper stud bolts for DN 150), the flanges set up a rigid cage easy to weld.
- Once the welding is finished, just pull the two flanges apart, insert the body between the flanges, refit the upper stud bolts and tighten back the nuts.
- The V16 is ready to operate.

Torque values for standard seats/Nm

DN	ΔP	Standard seats			Pressure relieving seats			Stem limiting torque (Nm)
		7	16	25	7	16	25	
65		90	105	130	78	105	130	615
80		105	130	160	95	130	160	615
100		140	190	230	120	190	230	615
150		-	-	-	-	-	-	-

Torques measured with water 1cPo viscosity at 20°C

Other seats: TFM/Carbon PTFE: +20%; PEEK +30%

Other packing gland: graphite packing: +10%

Actuation and control

Actuation

- Pneumatic double acting and single acting actuators.
- Electric actuators. Double acting and single acting spring return.
- Electric actuators for special applications.

Control

- Various control devices (spool valves, limit switch box).
- Pneumatic, electro-pneumatic and intelligent positioners.

Selection of pneumatic actuators series 79/D for standard seats

DN	Air supply (bar)	Double Acting Actuator ΔP (bar)				Single Acting Actuator ΔP (bar)			
		7	16	25	50	7	16	25	50
Application I									
65	4	024	024	024	-	065S-2.7	065S-2.7	065S-2.7	-
	6	012	012	024	-	036S-5.5	036S-5.5	065S-2.7	-
	8	012	012	012	-	024S-5.5	024S-6.9	036S-6.9	-
80	4	024	024	036	-	065S-2.7	065S-2.7	090S-3.4	-
	6	012	024	024	-	036S-5.5	065S-2.7	065S-5.5	-
	8	012	012	024	-	024S-6.9	036S-6.9	065S-5.5	-
100	4	024	036	065	-	090S-3.4	090S-3.4	090S-4.1	-
	6	024	024	036	-	065S-4.1	090S-3.4	090S-5.5	-
	8	012	024	024	-	036S-6.9	065S-5.5	065S-6.9	-
Application II									
65	4	024	024	036	-	065S-2.7	065S-2.7	090S-3.4	-
	6	012	024	024	-	036S-5.5	065S-2.7	065S-4.1	-
	8	012	012	024	-	036S-5.5	036S-6.9	065S-4.1	-
80	4	024	036	036	-	065S-2.7	090S-3.4	090S-4.1	-
	6	024	024	024	-	065S-2.7	065S-4.1	090S-3.4	-
	8	012	024	024	-	036S-6.9	065S-4.1	065S-5.5	-
100	4	036	065	065	-	090S-3.4	090S-4.1	*****	-
	6	024	036	036	-	090S-3.4	090S-5.5	*****	-
	8	024	024	024	-	065S-5.5	065S-6.9	090S-3.4	-

Notes

Application I: Water and waterlike fluids, temperature 20°C to 120°C standard service.

Application II: Dry fluids, high viscosity liquids, steam, oxygen service, heavy duty service, high temperature service > 120°C.