

6	BOLT	A193-B7
5	BONNET	A105
4	BONNET GASKET	304 +GRAPHITE
3	SPRING	A276-304
2	DISC	A276-420
1	BODY	A105N+13CR
Serial No.	Part Name	Material

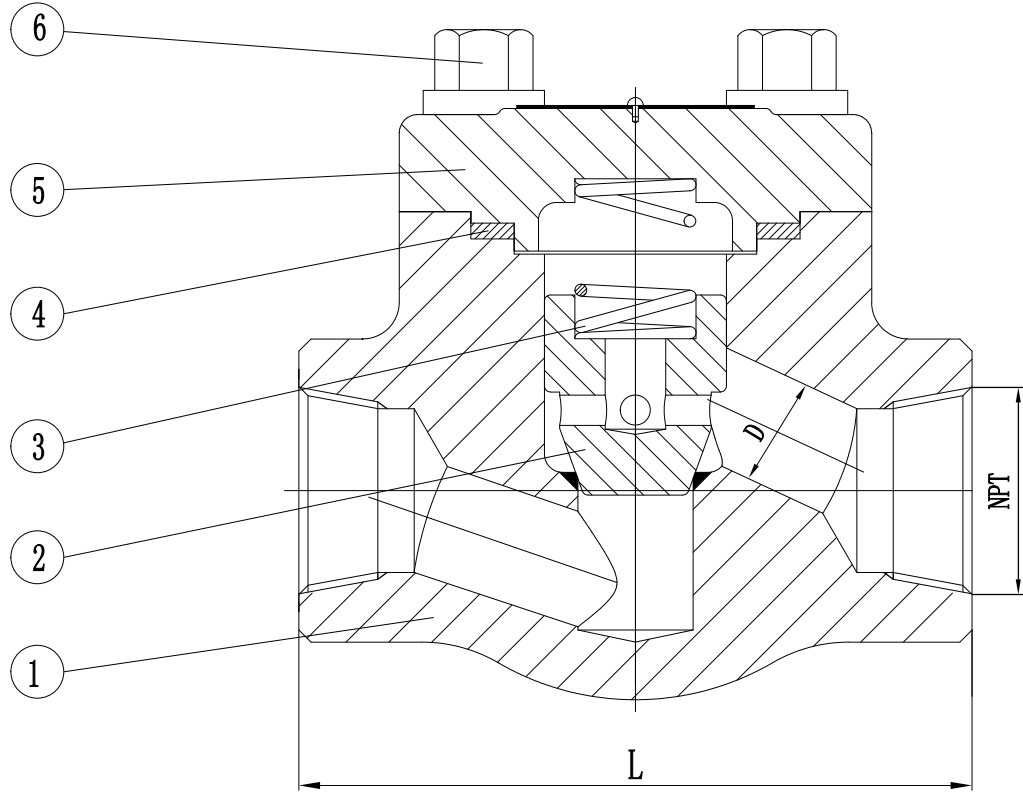

dimensions unit:mm

NPS	NPT	D	L
1/2	1/2	10	111
3/4	3/4	13	111
1	1	17	120
1-1/4	1-1/4	22	152
1-1/2	1-1/2	26	172
2	2	34	200

Specification Standard Sheet						
Shell Test Pressure	37.5	MPa				
High Pressure Seal Test	27.5					
Backseat Seal Test	27.5					
Air Test Pressure	0.6					
Applicable Temperature	-29~425° C		2015-11-27			
Applicable Medium	Water, Steam, Oil, etc	NO.	DATE	DESCRIPTION	PRP' D	REV' D
Design and manufacture	API 602	RD1500NPT-A105				
Face to face	ASME B16.34					
Screw end dimension	ANSI B1.20.1					
Pressure test	API 598					
CHECK VALVE	CLASS1500Lb-NPT	ASSEMBLING DRAWING				