

# coudes

séries 3000 - 6000

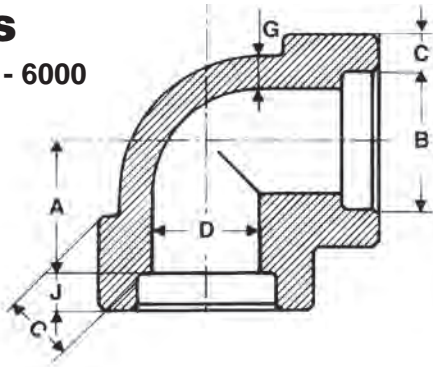

# elbows

class 3000 lb - 6000 lb

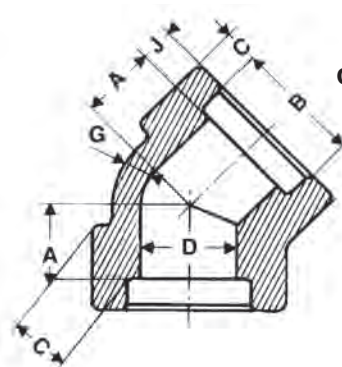

Dimensions B-C-D-G-J, voir caractéristiques dimensionnelles

For dimensions B-C-D-G-J refer to dimensions of S.W. fittings

Emboîtement à souder et dimensions suivant ASME B 16.11 - 2005  
 Socket welding end and dimensions according to ASME B 16.11 - 2005

# tés

tees

séries 3000 - 6000

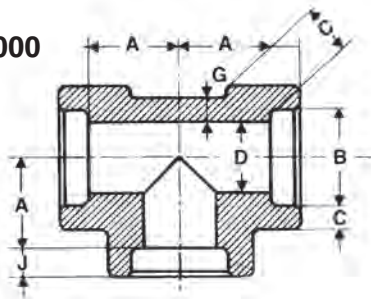

# croix

crosses

class 3000 lb- 6000 lb

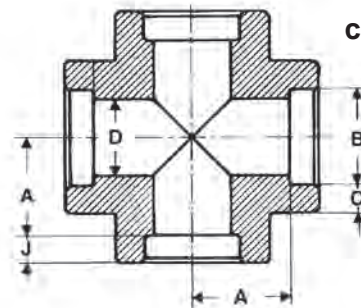

Emboîtement à souder et dimensions suivant ASME B 16.11 - 2005  
 Socket welding end and dimensions according to ASME B 16.11 - 2005

Diamètre nominal Nominal pipe size	Centre au fond de l'emboîtement A - Center to bottom of socket A									
	Coude 90° - Té - Croix				Coude 45°				Tolérances ±	
	3000		6000		3000		6000			
	mm	inches	mm	inches	mm	inches	mm	inches	mm	inches
1/4	11,0	0.44	13,5	0.53	8,0	0.31	8,0	0.31	1,0	0.03
3/8	13,5	0.53	15,5	0.62	8,0	0.31	11,0	0.44	1,5	0.06
1/2	15,5	0.62	19,0	0.75	11,0	0.44	12,5	0.50	1,5	0.06
3/4	19,0	0.75	22,5	0.88	13,0	0.50	14,0	0.56	1,5	0.06
1	22,5	0.88	27,0	1.06	14,0	0.56	17,5	0.69	2,0	0.08
1 1/4	27,0	1.06	32,0	1.25	17,5	0.69	20,5	0.81	2,0	0.08
1 1/2	32,0	1.25	38,0	1.50	20,5	0.81	25,5	1.00	2,0	0.08
2	38,0	1.50	41,0	1.62	25,5	1.00	28,5	1.12	2,0	0.08
2 1/2	41,0	1.62			28,5	1.12			2,5	0.10
3	57,0	2.25			32,0	1.25			2,5	0.10
4	66,5	2.62			41,0	1.62			2,5	0.10