



Ball Valves PN 16/40 AIT & IIT Construction (Carbon Steel and Stainless Steel)



Fig. 516/540

DIN 3357 and Fire Safe

Manufacturing program:

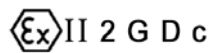

Quality & Environmental Management:





Ball Valves PN 16/40

DN 65 - 200 PN 16

DN 15 - 150 PN 40

Parts and materials

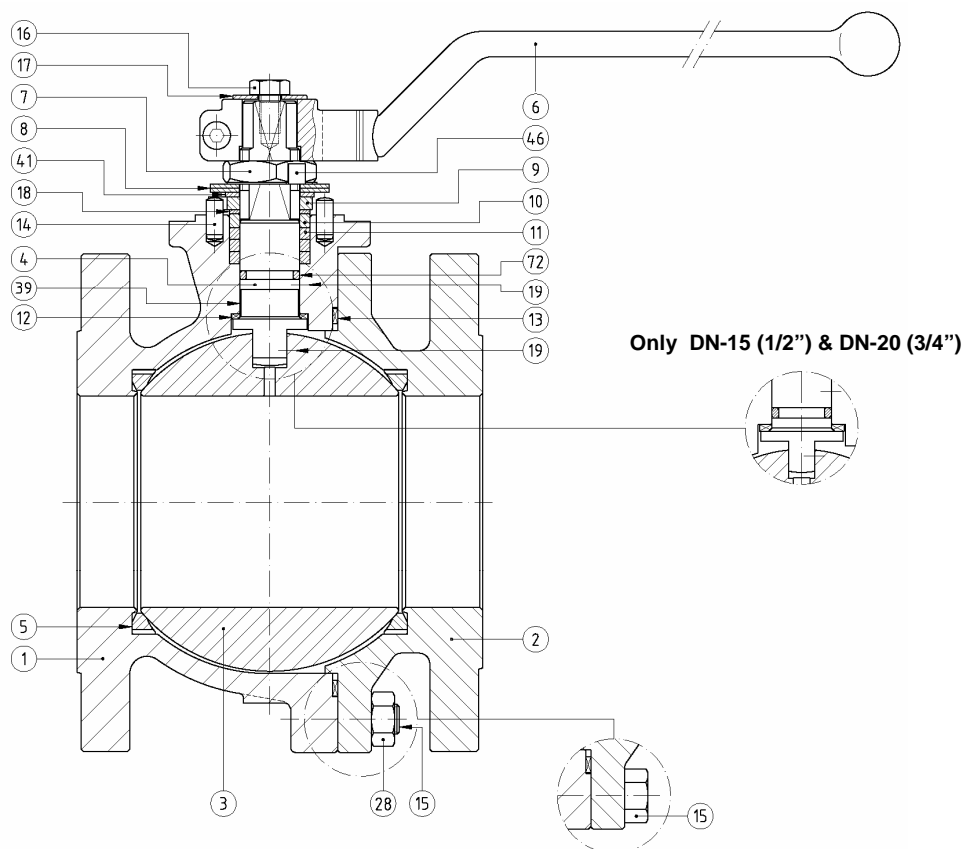

Item	Description	Material	
		AIT	IIT
1	Body	1.0619	1.4408
2	Body connector	1.0619	1.4408
3	Ball	A 351 Gr. CF8M (DN 15 : 25 A 479 Tp.316)	
4	Stem	A 479 Tp.316	
5	Seat ring	PTFE	
6	Wrench	Nodular Iron	
7	Gland nut	Zinc plated carbon steel	AISI 303
8	Disk spring	Carbon St.	E.N.P. Carbon St.
9	Stop plate	Carbon St.	AISI 304
10	Gland	AISI 303	AISI 316
11	Gland packing	Graphite	
12	Stem thrust seal	25% G.F. PTFE	
13	Body connector seal	AISI 316L + PTFE + Graphite	
14	Stop pin	Carbon St.	Stainless St.
15	Bolt (DN 32 to DN 100 Stud)	DIN 933 A4-70 (DN 32 to DN 100 : A4-70)	
16	Bolt	DIN 933 A4-70	
17	Washer	Zinc plated carbon steel	AISI 304
18	Thrust washer	25% G.F. PTFE	
19	Antistatic device	Stainless St.	
28	Nut (DN 32 to DN 100)	DIN 934 A4-70	
39	Stem bushing (DN 25 to DN 200)	25% G.F. PTFE	
41	Spacer (DN 40 to 200)	Carbon St.	AISI 304
46	Washer	AISI 304	
72	"O" Ring	FKM	
89	Identification plate	Stainless St.	



Ball Valves PN 16/40

DN 65 - 200 PN 16

DN 15 - 150 PN 40

Dimensions

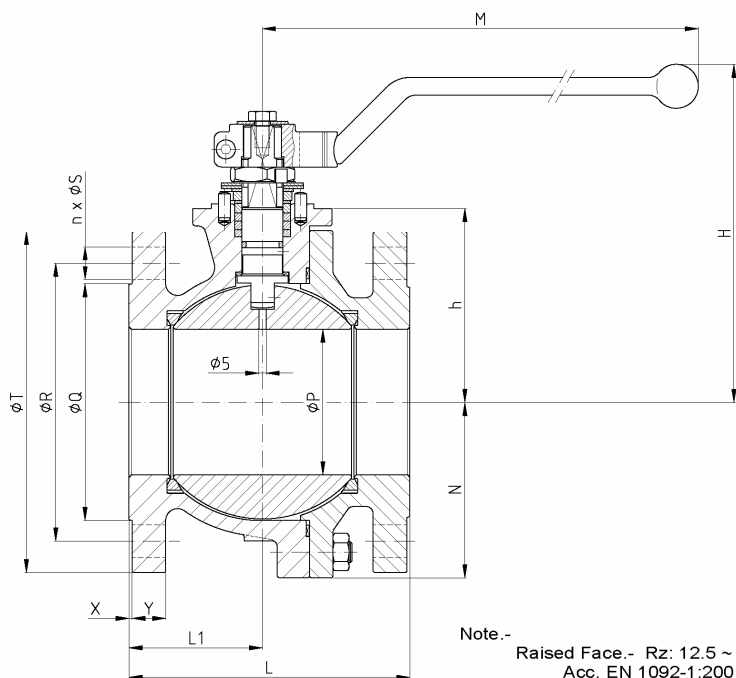

Only DN-15 (1/2") & DN-20 (3/4")

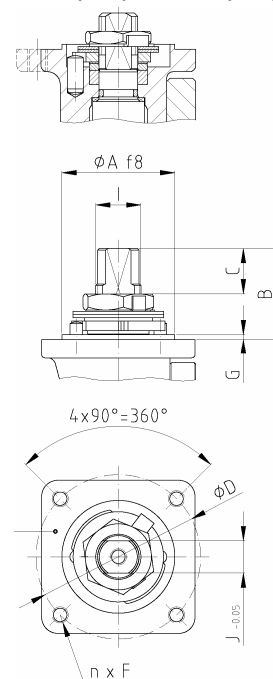

Note.-
Raised Face.- Rz: 12.5 ~ 50
Acc. EN 1092-1:2001

Series 516 (PN 16)

DN	ØP	L	L1	ØQ	ØR	n x ØS	ØT	X	Y	h	N	H	M	WEIGHT
65	65	170	75	122	145	4x18	169	3	15	97	---	169	348	16
80	80	180	81,5	138	160	8x18	207	3	17	111	---	207	445	22
100	100	190	90	158	180	8x18	231	3	17	133	118	231	495	32
125	125	325	120	188	210	8x18	262	3	19	156	137,5	262	698	52,5
150	151	350	135	212	240	8x22	298	3	19	183	160	298	698	76
200	203	400	200	268	295	12x22	352	3	21	233	208	352	868	111

(*) Dimensions in mm and weight in kg.

Series 540 (PN 40)

DN	ØP	L	L1	ØQ	ØR	n x ØS	ØT	X	Y	h	N	H	M	WEIGHT
15	15	115	53	45	65	4x14	97	2	14	46	---	97	224	2,8
20	20	120	52	58	75	4x14	104	2	16	53	---	104	224	3,6
25	25	125	52	68	85	4x14	117	2	16	58	---	117	224	5
32	32	130	54	80	100	4x18	131	2	16	66,5	---	131	287	7
40	40	140	55	88	110	4x18	148	3	15	76	---	148	315	9
50	50	150	61	102	125	4x18	155	3	17	83,5	---	155	315	12
65	65	170	75	122	145	8x18	169	3	19	97	---	169	348	17
80	80	180	81,5	138	160	8x18	207	3	21	111	---	207	445	23
100	100	190	90	162	190	8x22	231	3	21	133	118	231	495	35
125	125	325	120	188	220	8x26	262	3	23	156	137,5	262	698	57
150	151	350	135	218	250	8x26	298	3	25	183	160	298	698	83,5

(*) Dimensions in mm and weight in kg.

Actuator connection

DN	ISO 5211	ØA	B	C	ØD	n x F	G	I	J
15	F05	35	11,5	5,7	50	4x M6	1,5	M12x1.5	9
20	F05	35	15	9,2	50	4x M6	1,5	M12x1.5	9
25	F05	35	24	10,2	50	4xM6	1,5	M12x1.5	9
32	F05	35	32	12,2	50	4x M6	1,5	M16x1.5	12
40	F07	55	39,5	16,2	70	4x M8	3	M18x1.5	13
50	F07	55	41,5	18,2	70	4x M8	3	M18x1.5	13
65	F07	55	44	18,1	70	4xM8	3	M22x1.5	16
80	F10	70	44,5	18,7	102	4xM10	3	M25x1.5	18
100	F10	70	56,5	28,5	102	4xM10	3	M28x1.5	20
125	F12	85	56	27,6	125	4xM12	3	M35x2	25
150	F12	85	66	35,2	125	4xM12	3	M40x1.5	29
200	F14	100	70	36	140	4xM16	4	M45x2	32

(*) Dimensions in mm

Ball Valves PN 16/40

DN 65 - 200 PN 16

DN 15 - 150 PN 40

General Characteristics, Torque & KV, P&T Rating

GENERAL CHARACTERISTICS	Fig.516/540 Series SFF	S plit Body	F loating Ball	F ull Bore
DESIGN STANDARDS				
Valves design	DIN 3357	EN 1983		
Body design	DIN 3840			
Shell thickness	BS 5351			
Flanges	DIN 2501	EN 1092-1		
Face to face dimensions	DIN 3202 F18	EN 558-1 Series 27		
Actuator mounting flange	ISO 5211	DIN 3337		
Shell finishing quality	MSS SP 55			
Marking	BS 5351	EN 19	CE - PED	
TESTS AND CERTIFICATES				
Quality Assurance	ISO 9001	CE-PED		
Fire Safe certification	BS 6755 Part 2	ISO 10497: 2004		
Pressure testing	DIN 3230	BS 6755 Part 1	EN 12266	NF E 29-203
Other	ISO 14001	ATEX		

Torque Values in Nm

VALVE SIZE	AT DIFFERENTIAL PRESSURE		VALVE SIZE	AT DIFFERENTIAL PRESSURE	
	16 bar	40 bar		16 bar	40 bar
DN 15		10	DN 65	55	80
DN 20		14	DN 80	85	130
DN 25		16	DN 100	130	150
DN 32		25	DN 125	180	240
DN 40		30	DN 150	250	480
DN 50		55	DN 200	580	

Kv Values in m³/h

DN 15	DN 20	DN 25	DN 32	DN 40	DN 50
20	40	75	130	170	270
DN 65	DN 80	DN 100	DN 125	DN 150	DN 200
550	1000	1650	3000	4200	9000

Pressure-Temperature

