



**BONETTI**®

Piston Valves



# INDEX

	Page		Page
Rating .....	2	- Flanged Ends	
General Information .....	3	- to DIN - PN 16 – DN 15÷50	
Construction Details .....	4-5	reduced bore .....	14
<b>Straight Pattern</b>		- to DIN - PN 40 – DN 15÷50	
- Female Screwed Ends - PN 16.....	6	reduced bore .....	15
- Female Screwed Ends - PN 40/63, API 602.....	7	- to ASME Class 150 lb – DN 1/2"÷6" .....	16
- Socket Weld Ends (SW) - API 602 - 800 lb .....	8	- to ASME Class 300 lb – DN 1/2"÷6" .....	17
- Butt Weld Ends (BW) - API 602 - 800 lb .....	9	<b>Actuated Valves</b> .....	18
- Flanged Ends		<b>Flow Coefficient</b> .....	19
- to DIN - PN 16 – DN 10÷150 .....	10	<b>Valve Rings</b> .....	20
- to DIN - PN 16 – DN 65÷200 .....	11	<b>Conversion Table</b> .....	23
- to DIN - PN 40 – DN 10÷50 .....	12		
- to DIN - PN 40 – DN 65÷200 .....	13		

## FIGURE NUMBER INDEX

Fig.	Page	Fig.	Page	Fig.	Page	Fig.	Page	Fig.	Page	Fig.	Page
1001	20	1018	6	1023	16	1053	16	1075	14	1080	12
1003	20	1020	5	1024	17	1061	2	1076	15	1206	18
1004	4	1020.1	5	1039	17	1063	20	1077	7	1207	18
1009	20	1021	11	1045	10	1071	20	1078	8	1208	18
1010	10	1022	13	1046	4	1072	20	1079	9		

**Fig. 1061 - RATING for the Materials mentioned in this Bulletin**

Max. Operating TEMPERATURE to DIN  °C	Max. Operating PRESSURE to				
	DIN 2401 Class PN 16	DIN 2401 Class PN 16	DIN 2401 Class PN 40	DIN 2401 Class PN 40	DIN 2401 Class PN 63
	Mater. Sched. G bar	Mater. Sched. GS bar	Mater. Sched. GS bar	Mater. Sched. FS - F - M/H bar	Mater. Sched. FS - M/H bar
-10 +20	16	16	40	40	63
120	16	16	38	40	63
200	13	13	33	35	50
250	11	12	32	32	45
300	10	11	28	28	40
350	=	10	24	24	36
400	=	=	=	21	32

Max. Operating TEMPERATURE to ASME and API  °C	Max. Operating PRESSURE to					
	ASME Class 150 Gr. 1.1	ASME Class 150 Gr. 2.2	ASME Class 300 Gr. 1.1	ASME Class 300 Gr. 2.2	API Class 800 Gr. 1.1	API Class 800 Gr. 2.2
	bar	bar	bar	bar	bar	bar
-29 +38	19.6	19.0	51.1	49.6	136.2	132.4
100	17.7	16.2	46.4	42.2	136.0	112.5
200	14.0	13.7	43.8	35.7	130.0	95.1
250	12.1	12.1	41.7	33.4	123.0	89.1
300	10.2	10.2	38.7	31.6	112.0	84.5
350	8.4	8.4	37.0	30.4	98.0	81.1
400	6.5	6.5	34.5	29.1	82.5	77.6
425	5.6	5.6	28.8	28.7	71.5	76.4

Max. Operating Conditions for Gr. 1.1 are related to valves of Carbon Steel (Mat. Sched. FS, F); for Gr. 2.2 to valves of Austenitic Stainless Steel (Mat. Sched. M/H).



# BONETTI® Piston Valves

## GENERAL INFORMATION

Tightness in piston valves is obtained by a piston, operated by a handwheel and a screwed spindle, moving through two packing rings. With piston high-positioned and held by the only upper valve ring (ensuring tightness to environment), the valve is open. With piston low-positioned and held also by the lower valve ring (ensuring inside tightness between valve inlet and outlet), the valve is closed. We have consequently a "soft seated" valve.

The contact between piston and rings (sealing effect) is suitably assured by means of the stud bolts with Belleville washers compensating pressure and temperature variations.

Typical feature of piston valves - compared with globe valves - is the piston always held at least by one ring. Therefore no vibrations during closing and opening operations, too.

The main feature of piston valve is that the two cylindrical seating surfaces (bottom valve ring and piston) come in contact only when the flow is already almost cutoff. A property, unique in BONETTI® piston valves: with valve completely open and piston completely reinserted in the upper valve ring, piston is protected against erosive/corrosive actions and depositing of foreign matter.

Piston valves - contrary to globe valves - are bidirectional, that is they can be installed on process line in both flowing directions; the most common installation is however with inlet of pressure fluid below valve piston.

Since no metallic sealing surfaces are present, there is a perfect interchangeability of pieces and each new spare can be immediately fitted without need of any adaptation to other existing pieces. Therefore easy in line (not under pressure) maintenance feasible by not specialized personnel, making valve like new.

## OPERATING RANGE

Engineering companies have been using successfully piston valves for more than 70 years. Their first application - still widespread - was with low/medium pressure steam.

Later on these valves have conformed to a range of requirements in the industrial sector and are used on process lines containing the most different fluids such as steam, superheated water, heat transfer fluid, ammonia, L.P.G., hydrocarbons, acids, alkali, etc.

The perfect tightness and the durable stability, ensured by our new patented graphite reinforced joints, have extended more and more the application of BONETTI® piston valves with harmful and inflammable fluids.

Our valves, thanks to the materials of their joints, are suitable for temperatures higher than 550°C. Therefore the limitation is not due to seating material but to body material and to the other pressure retaining parts (utilization with body of carbon steel is limited to 425°C).

## DESIGN

Piston valves are usually straight pattern valves with their spindle perpendicular to process line.

The present design is the result of our experience begun in 1926. Our last patterns have made a remarkable progress as to quality of joints and to the new valves DN 65 and larger sizes, for mean and high pressure showing balanced piston, rising nonrotating spindle. See details on page 5, where the valves Type BVe are described ("e" means balanced piston).

## OPERATIONS

Piston valves are shutoff valves. By replacement of the standard Lantern Bush with the Regulating Lantern the valves operate as manual/automatic Flow Control Valves. Since the piston is always held by the upper valve ring, no vibrations can occur.

The Piston Flow Control Valves contrary to Globe Flow control valves are perfectly seal tight. A very interesting operative function of the piston valves is of regulating for modulating service (see details on Page 18).

## RATINGS

The max operating Pressures, related to the max operating Temperatures per PN, are shown in the Table of Fig. 1061 on page 2 for orientation only. The max operating conditions are anyhow those recommended by the pertinent Control Organization on installation.

In case of heavy service with pipes exposed to shocks, vibrations, repeated stresses, condensate hammering etc., and with harmful fluids, patterns with body of steel, even for limited operating conditions, shall be selected.

When ordering or enquiring, the valve heaviest operating conditions (kind of fluid, pressure, temperature), shall be advised.

## MATERIAL SCHEDULES

For "Material Schedule" we mean the material quality of the valve components.

All valves can have some external parts (not in contact with fluid) in copper alloys. Exclusion of copper and its alloys shall be specially requested. Material Schedule Denomination shall be followed, in this case, by "H"; e.g. "G/H", "FS/H", "F/H".

Fig. 1062 - Material Schedules

Material Schedule	Materials	
	Body	Piston
G	Cast iron	Stainless steel
GS	Nodular iron	Stainless steel
FS	Forged steel	Stainless steel
F	Cast steel	Stainless steel
M/H	Stainless steel	Stainless steel

## SIZES (DN)

Standard sizes are DN 10 (3/8") through DN 200 (8").

## CONNECTIONS

Pipe connections are:

- flanged to UNI (DIN, AFNOR etc.)
- flanged to ANSI B 16.5, Classes 150 and 300 lb
- female screwed
- socket weld
- butt weld

## ACTUATED VALVES

BONETTI® Piston Valves of any DN, PN, Material Schedule can be equipped with pneumatic, hydraulic or electric actuator for remote control. See details on page 18.

## MAINTENANCE

Maintenance of Piston Valves is very easy and can be made while the valve is in position, but not in service and when fluid is escaping to atmosphere.

## SHIPPING PREPARATION

Our valves are supplied after passing the prescribed dimensional and functional test. All valves are protected by polythene closures on connections and external painting for storage and shipping purposes. Wooden containers are recommended for overseas shipments.

## QUALIFICATION

BONETTI® Piston Valves have been qualified according to:

- API 6 FA and BS 6775: Fire Safe
- TA Luft: German Clean Air, TÜV Mannheim
- Druckbehälterverordnung § 22: for railway and road tankers down to -40°C, TÜV München
- others.

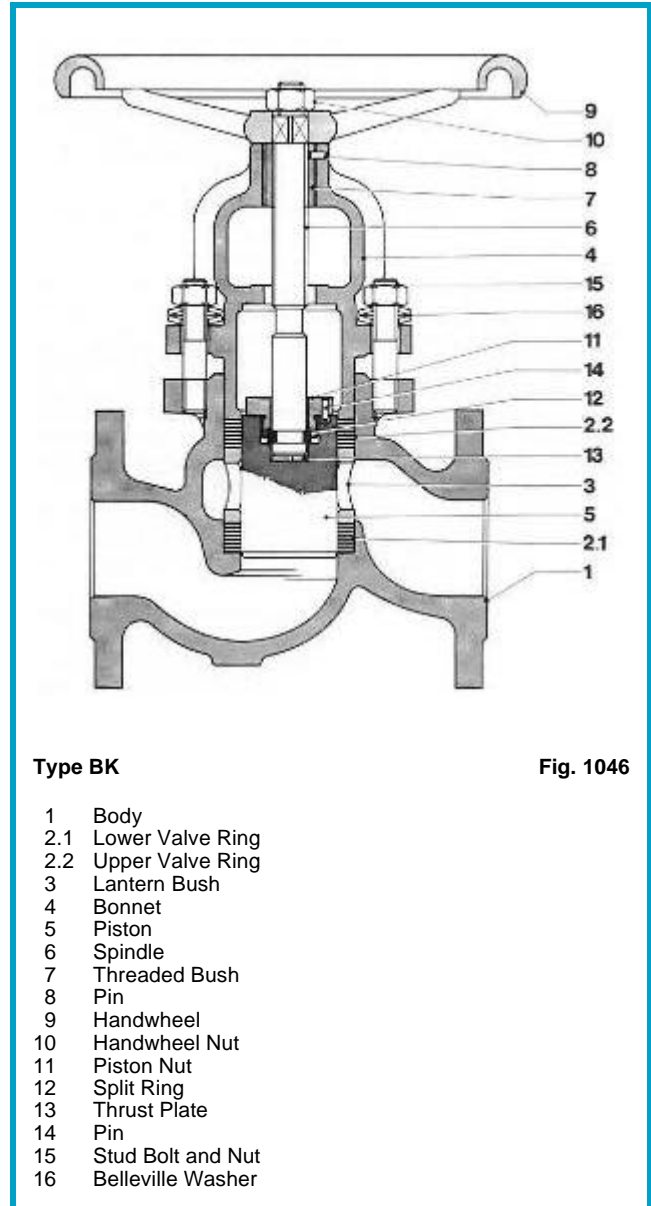
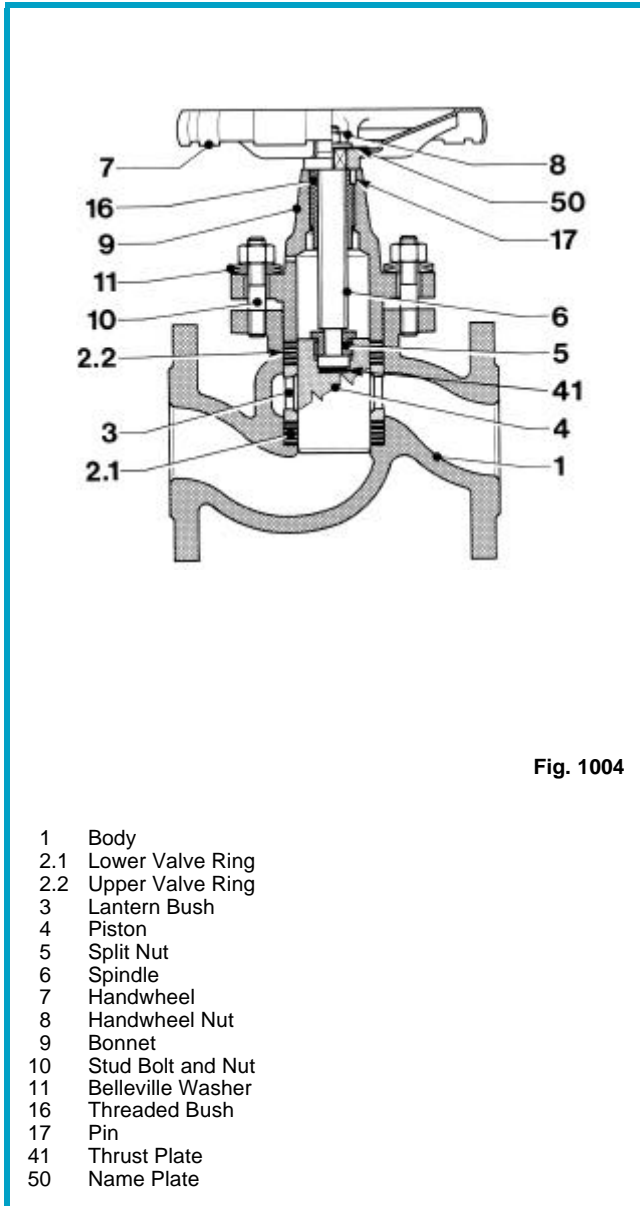

Fig. 1004 shows the simplest pattern of BONETTI® piston valves. Valve consists of a Body (1) where internally are fitted the Lower Valve Ring (2.1) ensuring upstream-downstream tightness, the Lantern Bush (3, Spacer between valve rings) and the Upper Valve Ring (2.2) ensuring tightness to environment. The two valve rings are adequately compressed by the Stud Bolts and Nuts (10) and by the Belleville Washers (11) which compensate expansion due to temperature variation.

The Piston (4) is axially operated by the Handwheel (7) and by the Spindle (6). With piston high-positioned and contacting the upper valve ring, the valve is open. With piston low-positioned and contacting both valve rings, valve is closed.

The opening stroke ends when the Split Nut (5) contacts the Bonnet (9); the closing stroke ends when the Handwheel (7) contacts the Bonnet (9). The BONETTI® piston valves are manufactured according to Fig. 1004:

- sizes DN 10 through DN 50, for PN 16 and PN 40
- sizes DN 65 through DN 150, for PN 16.

The valves of this pattern are fitted with non-balanced piston and are denominated BVn, where "n" means "non-balanced".

All valves are fitted with antifriction threaded bush in the bonnet and thrust plate between spindle and piston.

Fig. 1046 shows a BONETTI® piston valve type BK, essentially with the same design as the one of Fig. 1004, but suitable for mean/high pressure and for DN 65 through 150.

The coupling between screwed Spindle (6) and Piston (5) is obtained by means of a Split Ring (12) and a Piston Nut (11).

Axial thrust for valve closing is operated by a Thrust Plate (13).

The overall dimensions of Fig. 1046 valves are identical to those of the other valve having same DN and PN, as to body length and flanges.

The deviating dimensions are:

DN	65	80	100	125	150
G (mm)	320	365	420	470	530
H (mm)	390	445	515	575	655
V (mm)	250	300	350	350	400

These valves are specially suitable for railway and road tankers transporting L.P.G., ammonia and hydrocarbons. Most present tankers are equipped with BONETTI® piston valves Type BK.

Approved by TÜV.

# BONETTI® Piston Valves

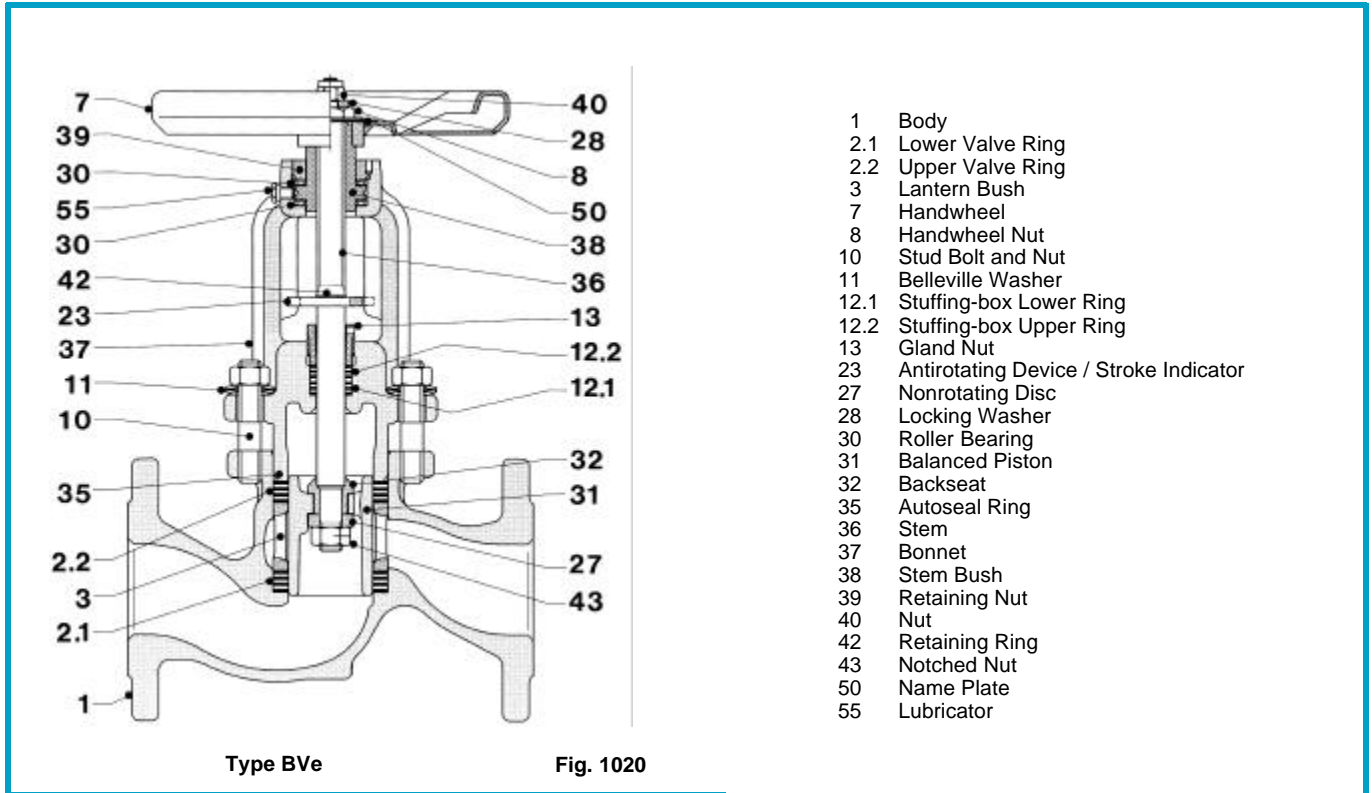

- 1 Body
- 2.1 Lower Valve Ring
- 2.2 Upper Valve Ring
- 3 Lantern Bush
- 7 Handwheel
- 8 Handwheel Nut
- 10 Stud Bolt and Nut
- 11 Belleville Washer
- 12.1 Stuffing-box Lower Ring
- 12.2 Stuffing-box Upper Ring
- 13 Gland Nut
- 23 Antirotating Device / Stroke Indicator
- 27 Nonrotating Disc
- 28 Locking Washer
- 30 Roller Bearing
- 31 Balanced Piston
- 32 Backseat
- 35 Autoseal Ring
- 36 Stem
- 37 Bonnet
- 38 Stem Bush
- 39 Retaining Nut
- 40 Nut
- 42 Retaining Ring
- 43 Notched Nut
- 50 Name Plate
- 55 Lubricator

Fig. 1020 shows a BONETTI® piston valve Type BVe with balanced piston ("e" means "balanced") with rising nonrotating stem. This pattern is required when the thrust against piston (at fairly high operating pressure and with large bore size) reaches so high values that valve operation becomes difficult. The fluid pressure in the balanced-piston valve is released also against the Bonnet (37), equipped with a standard Gland Nut (13) and Rings (12.1 and 12.2).

In this absolutely new pattern of standard piston valves:

- the Screwed Stem (36) is rising and nonrotating, the Antirotating Device (23) is used as a Stroke Indicator too,
- a perfect backseating is obtained by the Backseat (32) wedging between Stem (36) and Bonnet (37) with axial nonrotating motion,
- torque is reduced by two Roller Bearings (30),
- valve tightness between Body (1) and Bonnet (37) is also ensured by an additional Autoseal Ring (35), pressure seal type.

A perfect and durable tightness is obtained in this way. We avoid in this way fitting of a third ring (similar to the two others) which would take up a considerable part of the compressive stress exerted by the Stud Bolts and would hinder its transmission to the Lower Sealing Valve Ring (2.1).

These valves are usually equipped with special graphite rings showing the following main advantages:

- elimination of asbestos (ecology, health),
- resistance to nearly all usual fluids,
- remarkable temperature stability and therefore extension of operating range towards high temperatures, since limits do not depend on valve ring material but on quality of body metallic material,
- reduced friction coefficient and consequently longer life of both rings and other valve elements (screwed stem, stem bush, etc.).

PTFE valve rings can be fitted on request and for special applications.

BONETTI® piston valves are manufactured in accordance with the Fig. 1020, that is of Type BVe:

- size DN 65 through DN 200 for PN 16
- size DN 65 through DN 200: for PN 40, ASME 150 lb, ASME 300 lb.

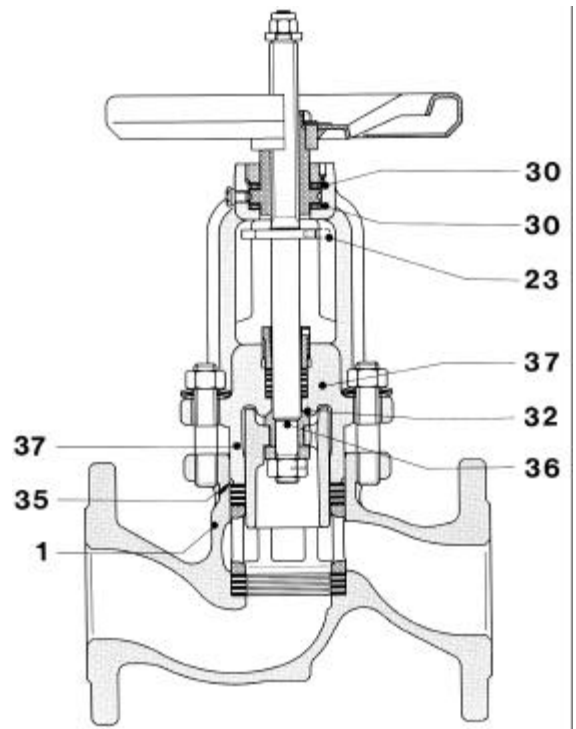

**Fig. 1020.1**

# BONETTI® Piston Valves – Cast Iron

## Stop Valves

### Female Screwed Ends

Rating: DIN 2401 - PN 16

Size 3/8" to 2"

- 1 Standard female screwed ends to B.S.P. (DIN 2999).
- 2 Length of body (A) to DIN 3202 - M9 - (except 1.1/2", 2" and type B V R).
- 3 Standard Material Schedule: G - PN 16.
- 4 Pressure - Temperature Rating on page 2.

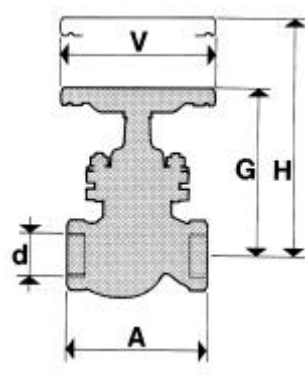

Fig. 1018

Type	DN inches	Fig.	Mater. Sched.	B.S.P. Thread d inches	Dimensions				Weight kg	Valve Rings (see page 20)		
					A mm	G mm	H mm	V mm		d mm	D mm	h mm
BV	3/8"	1018	G	3/8"	100	110	140	95	1,3	15	23,5	9
BV	1/2"	1018	G	1/2"	100	110	140	95	1,3	15	23,5	9
BV	3/4"	1018	G	3/4"	120	135	170	115	2,1	20	30	10
BV	1"	1018	G	1"	135	150	185	115	3,1	25	38	12
BV	1.1/4"	1018	G	1.1/4"	160	170	215	150	5,0	30	45	15
BV	1.1/2"	1018	G	1.1/2"	175	195	250	150	7,0	40	58	16
BV	2"	1018	G	2"	195	225	285	150	10,9	50	70	17
BVR	3/4"	1018	G	3/4"	100	110	140	95	1,4	15	23,5	9
BVR	1"	1018	G	1"	120	135	170	115	2,3	20	30	10

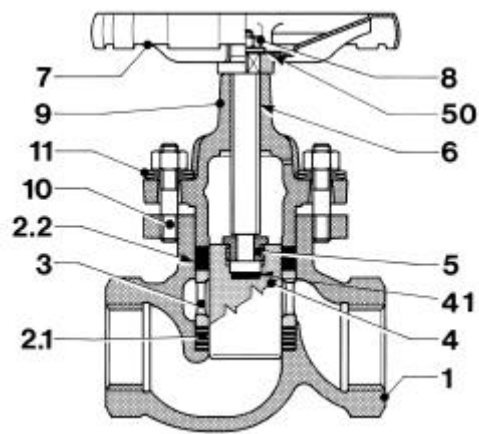

Fig. 1018

Part	Part Material for Material Schedule G
1 Body	GG 25 DIN 1691
2.1 Lower Valve Ring	Graphite T1
2.2 Upper Valve Ring	Graphite T4
3 Lantern Bush	Carbon Steel / GG 25 DIN 1691 ★
4 Piston	ASTM A582 - XM 34
5 Split Nut	● Fe37 + H.T.
6 Spindle	C30
7 Handwheel	Carbon Steel
8 Handwheel Nut	5.6 - 5-2
9 Bonnet	GG 25 DIN 1691
10 Stud Bolt and Nut	5.6 - 5-2
11 Belleville Washer	50 Cr V4
4.1 Thrust Plate	■ AISI 420 H.T.
50 Name Plate	Aluminium

● not existing for d = 15 and 20 mm

★ depending upon Size  
■ for Size 1.1/4" and larger, only



# BONETTI® Piston Valves – Steel

## Stop Valves

### Female Screwed Ends

Rating: API 602 - 800 lb

DIN 2401 - PN 40/63

Size 1/4" to 2"

- Standard female screwed ends to
  - B.S.P. (DIN 2999)
  - NPT - ANSI B2.1.
- Length of body (A) to DIN 3202 - M9, type BVR except.
- Standard Material Schedules: FS, F, M/H.
- Pressure - Temperature Rating on page 2.  
Size 2" BV type valves limited to 600 lb.

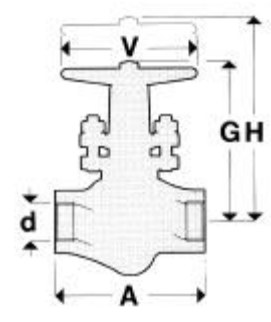

Fig. 1077

Type	DN inches	Fig.	Mater. Sched.	B.S.P. Thread d inches	Dimensions				Weight kg	Valve Rings (see page 20)		
					A mm	G mm	H mm	V mm		d mm	D mm	h mm
BV	3/8"	1077	FS - M/H	3/8"	100	110	140	95	1,9	15	23,5	9
BV	1/2"	1077	FS - M/H	1/2"	100	110	140	95	1,9	15	23,5	9
BV	3/4"	1077	FS - M:H	3/4"	120	135	170	115	3,3	20	30	10
BV	1"	1077	FS - M/H	1"	135	150	185	150	4,7	25	38	12
BV	1.1/4"	1077	FS - M/H	1.1/4"	160	170	215	150	7,1	30	45	15
BV	1.1/2"	1077	FS - M/H	1.1/2"	185	195	250	150	11,0	40	58	16
BV	2"	1077	F - M/H	2"	220	225	285	200	12,7	50	70	17
BVR	1/4"	1077	FS - M/H	1/4"	85	90	109	75	1,2	10	18	6
BVR	3/8"	1077	FS - M/H	3/8"	85	90	109	75	1,2	10	18	6
BVR	1/2"	1077	FS - M/H	1/2"	85	90	109	75	1,2	10	18	6
BVR	3/4"	1077	FS - M/H	3/4"	100	110	140	95	1,8	15	23,5	9
BVR	1"	1077	FS - M/H	1"	120	135	170	115	3,2	20	30	10
BVR	1.1/4"	1077	FS - M/H	1.1/4"	135	150	185	150	4,9	25	38	12
BVR	1.1/2"	1077	FS - M/H	1.1/2"	160	170	215	150	6,8	30	45	15
BVR	2"	1077	FS - M/H	2"	185	195	250	150	10,2	40	58	16

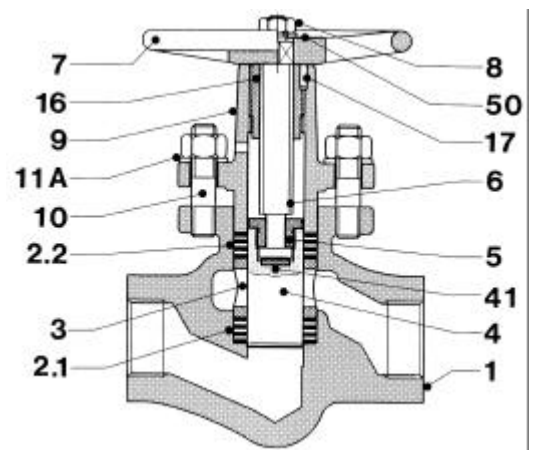

Fig. 1077

Part	Part Material for Material Schedule	
	FS - F	M/H
1 Body	ASTM A105 ★ ASTM A216 WCB ★	ASTM A182 F316 ★ ASTM A351 CF8M ★
2.1 Lower Valve Ring	Graphite T1	Graphite T1
2.2 Upper Valve Ring	Graphite T1	Graphite T1
3 Lantern Bush	Carbon Steel ★ GG 25 DIN 1691 ★	ASTM A479 Tp.316
4 Piston	ASTM A582 - XM 34	ASTM A479 Tp.316
5 Split Nut	● Fe37 + H.T.	Fe37 + H.T.
6 Spindle	A479 Tp410	A479 Tp410
7 Handwheel	Carbon Steel	Carbon Steel
8 Handwheel Nut	5-2	5-2
9 Bonnet	ASTM A105	ASTM A105
10 Stud Bolt and Nut	A193 B7 - A194 2H	A193 B7 - A194 2H
11A Washer	Carbon Steel	Carbon Steel
16 Threaded Bush	▲ ASTM A439 D2	ASTM A439 D2
17 Pin	▲ Carbon Steel	Carbon Steel
41 Thrust Plate	■ AISI 420 H.T.	AISI 420 H.T.
50 Name Plate	Aluminium	Aluminium

● not existing for d = 10, 15, 20 mm      ★ depending upon Size  
▲ for d = 30 mm and larger, only      ■ for d = 30 mm and larger, only



# BONETTI® Piston Valves – Steel

## Stop Valves

### Socket Weld Ends - SW

Rating: API 602 - 800 lb

DIN 2401 - PN 40/63

### Size 1/4" to 2"

- 1 Socket Weld Ends to ANSI B16.11.  
Minimum wall thickness of socket welding is 1,25 larger than nominal thickness of pipe having rating equal to valve rating.
- 2 End-to-End Dimension (A1) is not binding.
- 3 Standard Material Schedules: FS, F, M/H.
- 4 Pressure - Temperature Rating on page 2.  
**Size 2" BV type Valves limited to 600 lb.**

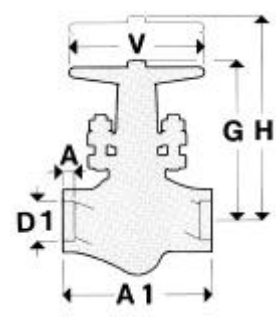

Fig. 1078

Type	DN inches	Fig.	Mater. Sched.	SW Ends.		Dimensions				Weight kg	Valve Rings (see page 20)		
				A mm	D1 mm	A1 mm	G mm	H mm	V mm		d mm	D mm	h mm
BV	3/8"	1078	FS - M/H	9,53	17,53	100	110	140	95	1,9	15	23,5	9
BV	1/2"	1078	FS - M/H	9,53	21,72	100	110	140	95	1,9	15	23,5	9
BV	3/4"	1078	FS - M/H	12,70	27,06	120	135	170	115	3,3	20	30	10
BV	1"	1078	FS - M/H	12,70	33,79	135	150	185	150	4,7	25	38	12
BV	1.1/4"	1078	FS - M/H	12,70	42,55	160	170	215	150	7,1	30	45	15
BV	1.1/2"	1078	FS - M/H	12,70	48,65	185	195	250	150	11,0	40	58	16
BV	2"	1078	F - M/H	15,88	61,12	220	225	285	200	12,7	50	70	17
BVR	1/4"	1078	FS - M/H	9,53	14,10	85	90	109	75	1,2	10	18	6
BVR	3/8"	1078	FS - M/H	9,53	17,53	85	90	109	75	1,2	10	18	6
BVR	1/2"	1078	FS - M/H	9,53	21,72	85	90	109	75	1,2	10	18	6
BVR	3/4"	1078	FS - M/H	12,70	27,06	100	110	140	95	1,8	15	23,5	9
BVR	1"	1078	FS - M/H	12,70	33,79	120	135	170	115	3,2	20	30	10
BVR	1.1/4"	1078	FS - M/H	12,70	42,55	135	150	185	150	4,9	25	38	12
BVR	1.1/2"	1078	FS - M/H	12,70	48,65	160	170	215	150	6,8	30	45	15
BVR	2"	1077	FS - M/H	15,88	61,12	185	195	250	150	10,2	40	58	16

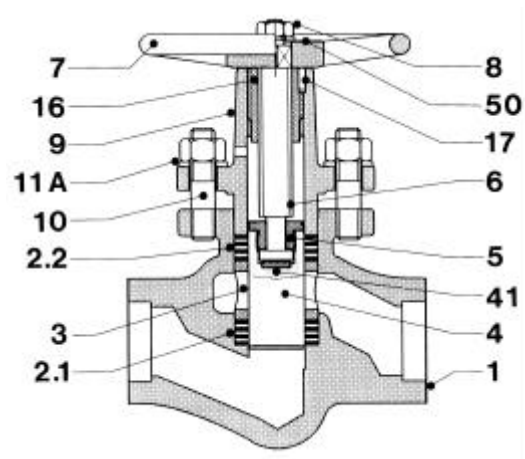

Fig. 1078

Part	Part Material for Material Schedule	
	FS - F	M/H
1 Body	ASTM A105 ★ ASTM A216 WCB ★	ASTM A182 F316 ★ ASTM A351 CF8M ★
2.1 Lower Valve Ring	Graphite T1	Graphite T1
2.2 Upper Valve Ring	Graphite T1	Graphite T1
3 Lantern Bush	Carbon Steel ★ GG 25 DIN 1691 ★	ASTM A479 Tp.316
4 Piston	ASTM A582 - XM 34	ASTM A479 Tp.316
5 Split Nut	● Fe37 + H.T.	Fe37 + H.T.
6 Spindle	▲ A479 Tp410	A479 Tp410
7 Handwheel	Carbon Steel	Carbon Steel
8 Handwheel Nut	5-2	5-2
9 Bonnet	ASTM A105	ASTM A105
10 Stud Bolt and Nut	▲ A193 B7 - A194 2H	▲ A193 B7 - A194 2H
11A Washer	Carbon Steel	Carbon Steel
16 Threaded Bush	▲ ASTM A439 D2	▲ ASTM A439 D2
17 Pin	▲ Carbon Steel	Carbon Steel
41 Thrust Plate	■ AISI 420 H.T.	■ AISI 420 H.T.
50 Name Plate	Aluminium	Aluminium

● not existing for d = 10, 15, 20 mm  
▲ for d = 30 mm and larger, only

★ depending upon Size  
■ for d = 30 mm and larger, only





# BONETTI® Piston Valves – Steel

## Stop Valves

### Butt Weld Ends - BW

Rating: API 602 - 800 lb

DIN 2401 - PN 40/63

### Size 1/4" to 2"

- Butt Weld Ends to ANSI B16.25 and pipe Sched. 160, or DIN 3239.  
When ordering, please indicate sizes of pipe to be welded to valve (outside and inside diameter).
- End-to-End Dimension (A2) is not binding.
- Standard Material Schedules: FS, F, M/H.
- Pressure - Temperature Rating on page 2.  
**Size 2" BV type Valves limited to 600 lb.**

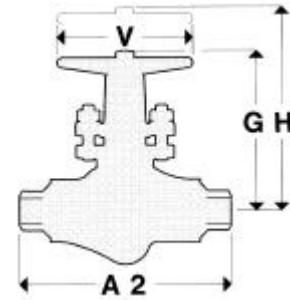

Fig. 1079

Type	DN inches	Fig.	Mater. Sched.	BW Ends			Dimensions				Weight kg	Valve Rings (see page 20)		
				d1 mm	d2 mm	d3 mm	A2 mm	G mm	H mm	V mm		d mm	D mm	h mm
BV	3/8"	1079	FS - M/H	10,7	13,9	17,1	100	110	140	95	1,9	15	23,5	9
BV	1/2"	1079	FS - M/H	11,8	15,0	21,3	100	110	140	95	1,9	15	23,5	9
BV	3/4"	1079	FS - M/H	15,6	18,8	26,7	120	135	170	115	3,4	20	30	10
BV	1"	1079	FS - M/H	20,7	23,9	33,4	135	150	185	150	4,8	25	38	12
BV	1.1/4"	1079	FS - M/H	29,5	32,7	42,2	160	170	215	150	7,3	30	45	15
BV	1.1/2"	1079	FS - M/H	34,0	37,2	48,3	185	195	250	150	11,5	40	58	16
BV	2"	1079	F - M/H	42,8	46,0	60,3	220	225	285	200	13,7	50	70	17
BVR	1/4"	1079	FS - M/H	7,7	10,9	13,7	85	90	109	75	1,2	10	18	6
BVR	3/8"	1079	FS - M/H	10,7	13,9	17,1	85	90	109	75	1,2	10	18	6
BVR	1/2"	1079	FS - M/H	11,8	15,0	21,3	85	90	109	75	1,2	10	18	6
BVR	3/4"	1079	FS - M/H	15,6	18,8	26,7	100	110	140	95	1,9	15	23,5	9
BVR	1"	1079	FS - M/H	20,7	23,9	33,4	120	135	170	115	3,5	20	30	10
BVR	1.1/4"	1079	FS - M/H	29,5	32,7	42,2	135	150	185	150	5,3	25	38	12
BVR	1.1/2"	1079	FS - M/H	34,0	37,2	48,3	160	170	215	150	7,6	30	45	15
BVR	2"	1079	FS - M/H	42,8	46,0	60,3	185	195	250	150	11,6	40	58	16

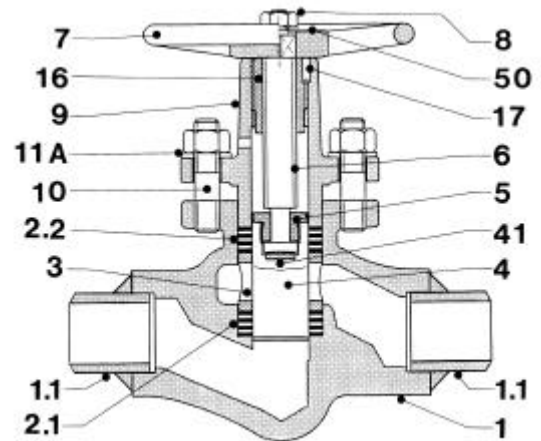
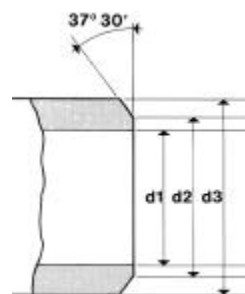

Fig. 1079

Part	Part Material for Material Schedule	
	FS - F	M/H
1 Body	ASTM A105 ★ ASTM A216 WCB ★	ASTM A182 F316 ★ ASTM A351 CF8M ★
1.1 Stud End	ASTM A106	ASTM A312 Tp.316
2.1 Lower Valve Ring	Graphite T1	Graphite T1
2.2 Upper Valve Ring	Graphite T1	Graphite T1
3 Lantern Bush	Carbon Steel ★ GG 25 DIN 1691 ★	ASTM A479 Tp.316
4 Piston	ASTM A582 - XM 34	ASTM A479 Tp.316
5 Split Nut	● Fe37 + H.T.	Fe37 + H.T.
6 Spindle	A479 Tp410	A479 Tp410
7 Handwheel	Carbon Steel	Carbon Steel
8 Handwheel Nut	5-2	5-2
9 Bonnet	ASTM A105	ASTM A105
10 Stud Bolt and Nut	A193 B7 - A194 2H	A193 B7 - A194 2H
11A Washer	Carbon Steel	Carbon Steel
16 Threaded Bush	▲ ASTM A439 D2	ASTM A439 D2
17 Pin	▲ Carbon Steel	Carbon Steel
41 Thrust Plate	■ AISI 420 H.T.	AISI 420 H.T.
50 Name Plate	Aluminium	Aluminium

● not existing for d = 10, 15, 20 mm  
▲ for d = 30 mm and larger, only

★ depending upon Size  
■ for d = 30 mm and larger, only



# BONETTI® Piston Valves - Cast Iron

## Stop Valves

Flanged Ends to DIN 2533 - PN 16

Rating: DIN 2401 - PN 16

Size DN 10 to DN 150

- 1 Standard Flanges are Raised Face, drilled.
- 2 Face-to-Face Dimension (A) to DIN 3202 - F1.
- 3 Standard Material Schedule: G - PN 16.
- 4 Pressure - Temperature Rating on page 2.

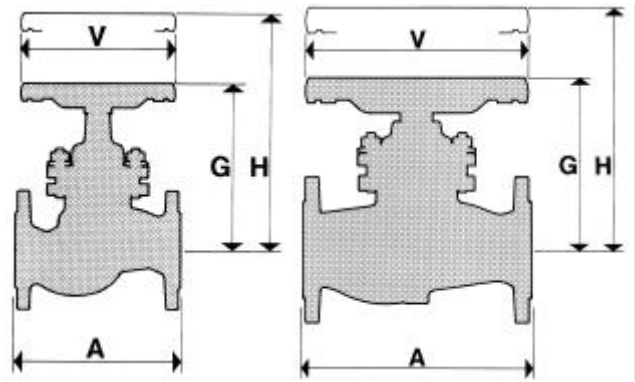

Fig. 1010

Fig. 1045

Type	DN mm	Fig.	Mater. Sched.	Dimensions				Flange Dimensions					Weight kg	Valve Rings (see page 20)		
				A mm	G mm	H mm	V mm	Outs. Dia. mm	Thick. mm	No. of Holes No.	Dia. of Holes mm	Dia. of Bolt Circle mm		d mm	D mm	h mm
BV	10	1010	G	120	110	140	95	90	14	4	14	60	2,3	15	23,5	9
BV	15	1010	G	130	110	140	95	95	14	4	14	65	2,5	15	23,5	9
BV	20	1010	G	150	135	170	115	105	16	4	14	75	3,8	20	30	10
BV	25	1010	G	160	150	185	125	115	16	4	14	85	5,3	25	38	12
BV	32	1010	G	180	170	215	150	140	18	4	18	100	7,7	30	45	15
BV	40	1010	G	200	195	250	150	150	18	4	18	110	11,3	40	58	16
BV	50	1010	G	230	225	285	200	165	20	4	18	125	15,4	50	70	17
BVn	65	1045	G	290	210	260	300	185	20	4	18	145	21,0	60	82	16
BVn	80	1045	G	310	230	290	300	200	22	8	18	160	28,0	70	94	19
BVn	100	1045	G	350	275	350	300	220	24	8	18	180	41,0	90	112	20
BVn	125	1045	G	400	310	395	400	250	26	8	18	210	65,0	110	135	22
BVn	150	1045	G	480	340	440	400	285	26	8	22	240	92,0	130	155	23

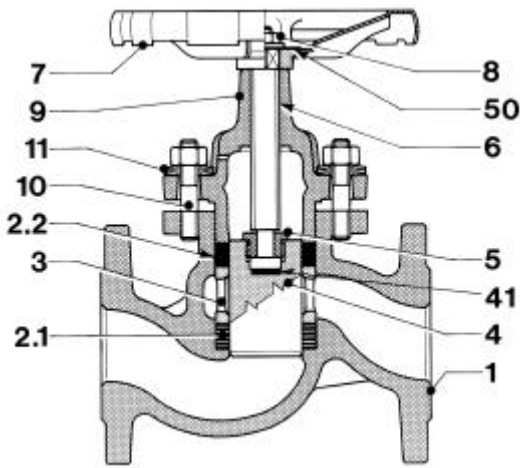

Fig. 1010

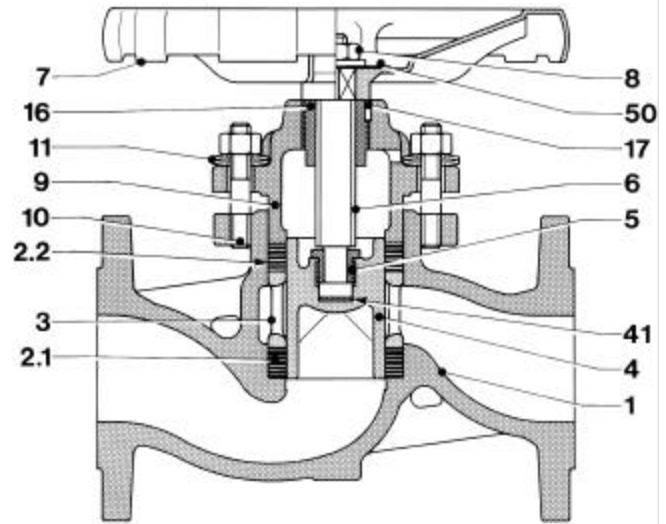

Fig. 1045

Part	Part Material for Material Schedule G
1 Body	GG 25 DIN 1691
2.1 Lower Valve Ring	Graphite T1
2.2 Upper Valve Ring	Graphite T4 / Graphite T1 ▲
3 Lantern Bush	Carbon Steel / GG 25 DIN 1691 ★
4 Piston	ASTM A582 - XM 34 ★ G-X 70 Cr Mo 29 2 ★
5 Split Nut	● Fe37 + H.T.
6 Spindle	C30
7 Handwheel	Carbon Steel
8 Handwheel Nut	5-2
9 Bonnet	GG 25 DIN 1691
10 Stud Bolt and Nut	5.6 - 5-2
11 Belleville Washer	50 Cr V4
16 Threaded Bush	▲ OT 58
17 Pin	▲ Carbon Steel
41 Thrust Plate	■ AISI 420 H.T.
50 Name Plate	Aluminium

● not existing for DN 10, 15, 20 mm

★ depending upon Size

▲ for Size 65 and larger only

■ for Size 32 and larger, only



# BONETTI® Piston Valves – Cast Iron, Nodular Iron

## Stop Valves – Type BVe

Flanged Ends to DIN 2533 - PN 16

Rating: DIN 2401 - PN 16

Size DN 65 to DN 200

- 1 Standard Flanges are Raised Face, drilled.
- 2 Face-to-Face Dimension (A) to DIN 3202 - F1.
- 3 Standard Material Schedule: G - PN 16, GS - PN 16.
- 4 Pressure - Temperature Rating on page 2.

These DN 200 valves are designed and suitable for PN 16.  
Some Countries accept DN 200 and larger sized valves of cast iron for lower PN, only. We suggest to examine carefully the relevant standards in force.

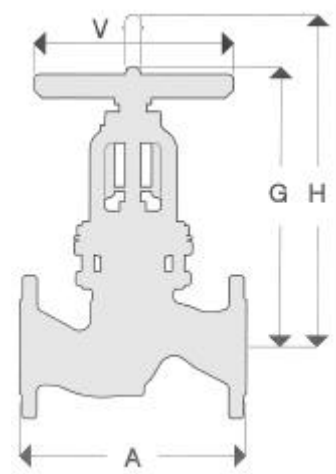

Fig. 1021

Type	DN mm	Fig.	Mater. Sched.	Dimensions				Flange Dimensions				Weight kg	Valve Rings (see page 20)			Stuffing-box Rings (see page 20)			
				A mm	G mm	H mm	V mm	Outs. Dia. mm	Thick. mm	No. of Holes No.	Dia. of Holes mm		Dia. of Bolt Circle mm	d mm	D mm	h mm	d mm	D mm	h mm
BVe	65	1021	G - GS	290	340	395	250	185	20	4	18	145	23,5	60	82	16	20	30	10
BVe	80	1021	G - GS	310	370	430	250	200	22	8	18	160	31,0	70	94	19	20	30	10
BVe	100	1021	G - GS	350	415	490	300	220	24	8	18	180	43,0	90	112	20	20	30	10
BVe	125	1021	G - GS	400	460	545	350	250	26	8	18	210	65,0	110	135	22	25	38	12
BVe	150	1021	G - GS	480	495	590	350	285	26	8	22	240	91,0	130	155	23	25	38	12
BVe	200	1021	G - GS	600	580	695	400	340	30	12	22	295	175,0	170	200	15	25	38	12

Part	Part Material for Material Schedule	
	G	GS
1 Body	GG 25 DIN 1691	GGG-40.3 DIN 1693
2.1 Lower Valve Ring	Graphite T1	Graphite T1
2.2 Upper Valve Ring	Graphite T1	Graphite T1
3 Lantern Bush	GG 25 DIN 1691	GG 25 DIN 1691
7 Handwheel	Carbon Steel	Carbon Steel
8 Handwheel Nut	Carbon Steel	Carbon Steel
10 Stud Bolt and Nut	5.6 - 5-2	5.6 - 5-2
11 Belleville Washer	50 Cr V4	50 Cr V4
12.1 Stuff.-box Lower Ring	Graphite T1	Graphite T1
12.2 Stuff.-box Upper Ring	Graphite T1	Graphite T1
13 Gland Nut	Carbon Steel	Carbon Steel
23 Antirrotating Device	Carbon Steel	Carbon Steel
Stroke Indicator		
27 Nonrotating Disc	Carbon Steel	Carbon Steel
28 Locking Washer	ASTM A182 F6	ASTM A182 F6
30 Roller Bearing	Alloy Steel	Alloy Steel
31 Balanced Piston	ASTM A582 XM34	ASTM A582 XM34
32 Backseat	ASTM A182 F6	ASTM A182 F6
35 Autoseal Ring	Graphite T3	Graphite T3
36 Stem	ASTM A479 Tp.410 c.3	ASTM A479 Tp.410 c.3
37 Bonnet	GG25 DIN 1691	GGG-40.3 DIN 1693
38 Stem Bush	ASTM A439 D2 / GGG NiCr	ASTM A439 D2 / GGG NiCr
39 Retaining Nut	Carbon Steel	Carbon Steel
40 Nut	Carbon Steel	Carbon Steel
42 Retaining Ring	Stainless Steel	Stainless Steel
43 Notched Nut	Carbon Steel	Carbon Steel
50 Name Plate	Aluminium	Aluminium
55 Lubricator	1/8" BSP	1/8" BSP

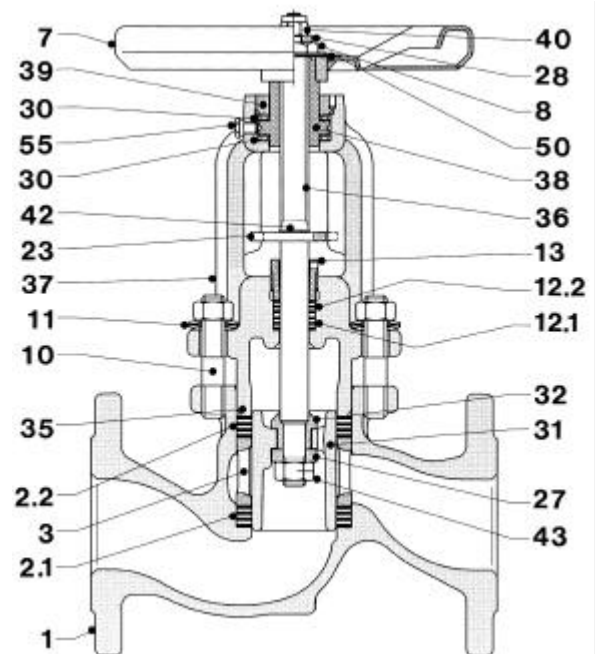

Fig. 1021

### Stop Valves

Flanged Ends to DIN 2545 - PN 40

Rating: DIN 2401 - PN 40

Size DN 10 to DN 50

- Standard Flanges are Raised Face, drilled.
- On request instead of Raised Face flanges can have following finishings:
  - large female to DIN 2513
  - groove to DIN 2512
- Face-to-Face Dimension (A) to DIN 3202 - F1.
- Standard Material Schedules: FS - PN 40, F - PN 40, M/H - PN 40, GS - PN 40.
- Pressure - Temperature Rating on page 2.

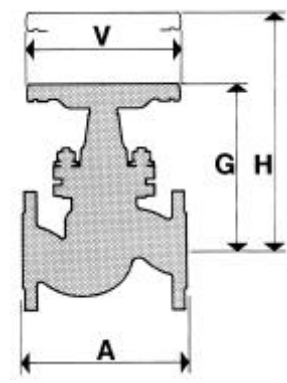

Fig. 1080

Type	DN mm	Fig.	Mater. Sched.	Dimensions				Flange Dimensions					Weight kg	Valve Rings (see page 20)		
				A mm	G mm	H mm	V mm	Outs. Dia. mm	Thick. mm	No. of Holes No.	Dia. of Holes mm	Dia. of Bolt Circle mm		d mm	D mm	h mm
BV	10	1080	FS - M/H - GS	120	110	140	95	90	16	4	14	60	2,6	15	23,5	9
BV	15	1080	FS - M/H - GS	130	110	140	95	95	16	4	14	65	2,9	15	23,5	9
BV	20	1080	FS - M/H - GS	150	135	170	115	105	18	4	14	75	4,4	20	30	10
BV	25	1080	FS - M/H - GS	160	150	185	125	115	18	4	14	85	6,1	25	38	12
BV	32	1080	F - M/H - GS	180	170	215	150	140	18	4	18	100	9,2	30	45	15
BV	40	1080	F - M/H - GS	200	195	250	150	150	18	4	18	110	12,2	40	58	16
BV	50	1080	F - M/H - GS	230	225	285	200	165	20	4	18	125	17,1	50	70	17

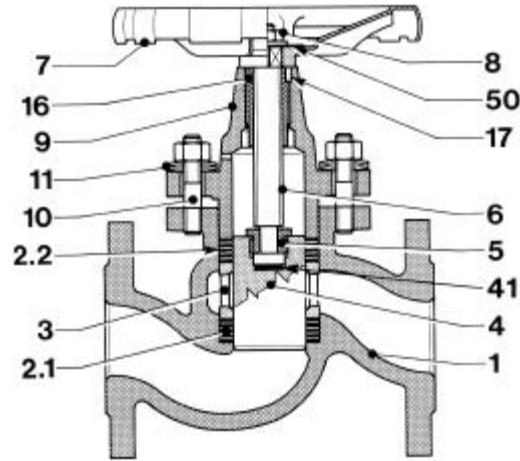

Fig. 1080

Part	Part Material for Material Schedule		
	FS - F	M/H	GS
1 Body	C22.8 ★ GS - C 25 ★	X5 Cr Ni Mo 17 22 2 ★ G - X6 Cr Ni Mo 18 10 ★	GGG-40.3 DIN 1693
2.1 Lower Valve Ring	Graphite T1	Graphite T1	Graphite T1
2.2 Upper Valve Ring	Graphite T1	Graphite T1	Graphite T1
3 Lantern Bush	Carbon Steel. / GG 25 ★	X5 Cr Ni Mo 17 22 2	Carbon Steel. / GG 25 ★
4 Piston	ASTM A582 - XM 34	X5 Cr Ni Mo 17 22 2	ASTM A582 - XM 34
5 Split Nut	● Fe37 + H.T.	Fe37 + H.T.	Fe37 + H.T.
6 Spindle	A479 Tp410	A479 Tp410	A479 Tp410
7 Handwheel	Carbon Steel	Carbon Steel	Carbon Steel
8 Handwheel Nut	5-2	5-2	5-2
9 Bonnet	C22.8 / ASTM A105	C22.8 / ASTM A105	GGG-40.3 DIN 1693
10 Stud Bolt and Nut	5.6 - 5-2	5.6 - 5-2	5.6 - 5-2
11 Belleve Washer	50 Cr V4	50 Cr V4	50 Cr V4
16 Threaded Bush	▲ OT 58	ASTM A439 D2	OT 58
17 Pin	▲ Carbon Steel	Carbon Steel	Carbon Steel
41 Thrust Plate	■ AISI 420 H.T.	AISI 420 H.T.	AISI 420 H.T.
50 Name Plate	Aluminium	Aluminium	Aluminium

● not existing for DN 10, 15, 20 mm

▲ for Size 32 and larger only

★ depending upon Size

■ for Size 32 and larger, only

# BONETTI® Piston Valves – Steel, Nodular Iron

**Stop Valves – Type BVe**  
**Flanged Ends to DIN 2545 - PN 40**  
**Rating: DIN 2401 - PN 40**  
**Size DN 65 to DN 200**

- 1 Standard Flanges are Raised Face, drilled.
- 2 On request instead of Raised Face flanges can have following finishings:  
 - large female to DIN 2513  
 - groove to DIN 2512.
- 3 Face-to-Face Dimension (A) to DIN 3202 - F1.
- 4 Standard Material Schedules: F - PN 40, M/H - PN 40, GS - PN 40.
- 5 Pressure - Temperature Rating on page 2.

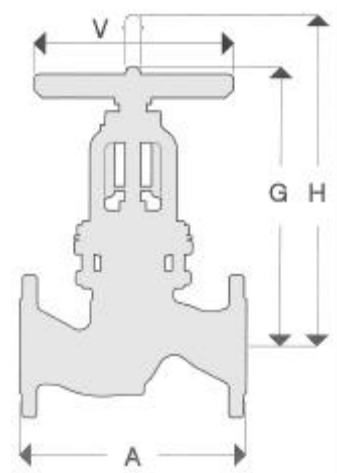

Fig. 1022

Type	DN	Fig.	Mater. Sched.	Dimensions				Flange Dimensions				Weight	Valve Rings (see page 20)			Stuffing-box Rings (see page 20)			
				A	G	H	V	Outs. Dia.	Thick.	No. of Holes	Dia of Holes		Dia of Bolt Circle	d	D	h	d	D	h
	mm			mm	mm	mm	mm	mm	mm	No.	mm	mm	kg	mm	mm	mm	mm	mm	mm
BVe	65	1022	F - M/H - GS	290	345	400	250	185	22	8	18	145	26	60	82	16	20	30	10
BVe	80	1022	F - M/H - GS	310	375	435	250	200	24	8	18	160	33	70	94	19	20	30	10
BVe	100	1022	F - M/H - GS	350	415	490	300	235	24	8	22	190	50	90	112	20	20	30	10
BVe	125	1022	F - M/H - GS	400	460	545	350	270	26	8	25	220	80	110	135	22	25	38	12
BVe	150	1022	F - M/H - GS	480	495	590	350	300	28	8	25	250	110	130	155	23	25	38	12
BVe	200	1022	F - M/H - GS	600	580	695	400	375	34	12	29	320	190	170	200	15	25	38	12

Part	Part Material for Material Schedule		
	F	M/H	GS
<b>1 Body</b>	GS - C 25 / ASTM A216 WCB	G - X6 Cr Ni Mo 18 10 / ASTM A351 CF8M	GGG-40.3 DIN 1693
<b>2.1 Lower Valve Ring</b>	Graphite T1	Graphite T1	Graphite T1
<b>2.2 Upper Valve Ring</b>	Graphite T1	Graphite T1	Graphite T1
<b>3 Lantern Bush</b>	GG 25 DIN 1691	X5 Cr Ni Mo 18 10 / ASTM A182 F316	GG 25 DIN 1691
<b>7 Handwheel</b>	Carbon Steel	Carbon Steel	Carbon Steel
<b>8 Handwheel Nut</b>	Carbon Steel	Carbon Steel	Carbon Steel
<b>10 Stud Bolt and Nut</b>	5.6 - 5-2	5.6 - 5-2	5.6 - 5-2
<b>11 Belleville Washer</b>	50 Cr V4	50 Cr V4	50 Cr V4
<b>12.1 Stuff.-box Lower Ring</b>	Graphite T1	Graphite T1	Graphite T1
<b>12.2 Stuff.-box Upper Ring</b>	Graphite T1	Graphite T1	Graphite T1
<b>13 Gland Nut</b>	Carbon Steel	Stainless Steel	Carbon Steel
<b>23 Antirotating Device Stroke Indicator</b>	Carbon Steel	Stainless Steel	Carbon Steel
<b>27 Nonrotating Disc</b>	Carbon Steel	ASTM A182 F316	Carbon Steel
<b>28 Locking Washer</b>	ASTM A182 F6	ASTM A182 F6	ASTM A182 F6
<b>30 Roller Bearing</b>	Alloy Steel	Alloy Steel	Alloy Steel
<b>31 Balanced Piston</b>	ASTM A582 - XM 34	X5 Cr Ni Mo 17 12 2 / ASTM A479 Tp.316	ASTM A582 - XM 34
<b>32 Backseat</b>	ASTM A182 F6	ASTM A182 F316	ASTM A182 F6
<b>35 Autoseal Ring</b>	Graphite T3	Graphite T3	Graphite T3
<b>36 Stem</b>	ASTM A479 Tp.410 c.3	ASTM A564 T.630 / X5 Cr Ni Cu Nb 17 4	ASTM A479 Tp.410 c.3
<b>37 Bonnet</b>	GS - C 25 / ASTM A216 WCB	G - X6 Cr Ni Mo 18 10 / ASTM A351 CF8M	GGG-40.3 DIN 1693
<b>38 Stem Bush</b>	ASTM A439 D2 / GGG NiCr	ASTM A439 D2 / GGG NiCr	ASTM A439 D2 / GGG NiCr
<b>39 Retaining Nut</b>	Carbon Steel	Carbon Steel	Carbon Steel
<b>40 Nut</b>	Carbon Steel	Carbon Steel	Carbon Steel
<b>42 Retaining Ring</b>	Stainless Steel	Stainless Steel	Stainless Steel
<b>43 Notched Nut</b>	Carbon Steel	Stainless Steel T.316	Carbon Steel
<b>50 Name Plate</b>	Aluminium	Aluminium	Aluminium
<b>55 Lubricator</b>	1/8" BSP	1/8" BSP	1/8" BSP

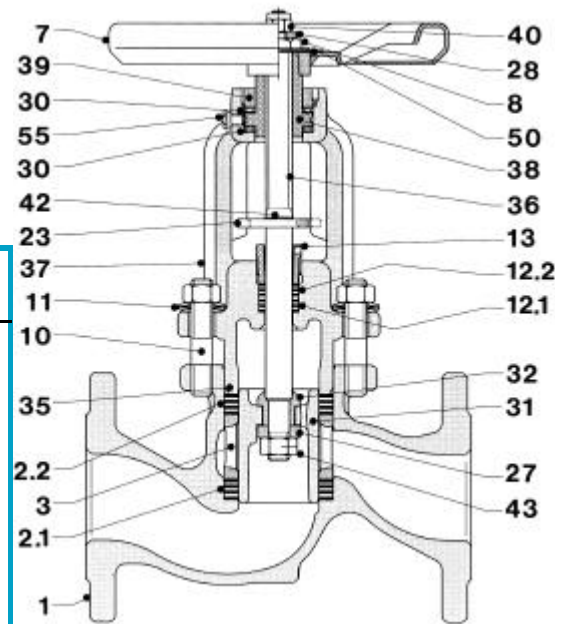

Fig. 1022

# BONETTI® Piston Valves – Cast Iron

Stop Valves, Reduced Bore, Type BVR  
 Flanged Ends to DIN 2533 - PN 16  
 Rating: DIN 2401 - PN 16  
 Size DN 15 to DN 50

- 1 Standard Flanges are Raised Face, drilled.
- 2 Face-to-Face Dimension (A) to DIN 3202 - F1.
- 3 Standard Material Schedule: G - PN 16.
- 4 Pressure - Temperature Rating on page 2.

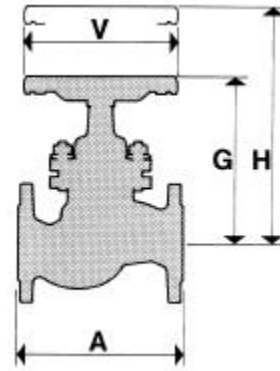

Fig. 1075

Type	DN mm	Fig.	Mater. Sched.	Dimensions				Flange Dimensions					Weight kg	Valve Rings (see page 20)		
				A mm	G mm	H mm	V mm	Outs. Dia. mm	Thick. mm	No. of Holes No.	Dia. of Holes mm	Dia. of Bolt Circle mm		d mm	D mm	h mm
BVR	15	1075	G	130	90	108	75	95	14	4	14	65	2,2	10	18	6
BVR	20	1075	G	150	110	140	95	105	16	4	14	75	3,2	15	23,5	9
BVR	25	1075	G	160	135	170	115	115	16	4	14	85	4,5	20	30	10
BVR	32	1075	G	180	150	185	125	140	18	4	18	100	6,8	25	38	12
BVR	40	1075	G	200	170	215	150	150	18	4	18	110	8,6	30	45	15
BVR	50	1075	G	230	195	250	150	165	20	4	18	125	12,2	40	58	16

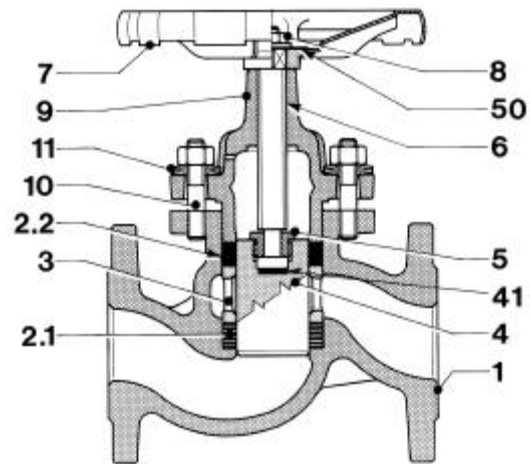

Fig. 1075

Part	Part Material for Material Schedule G
1 Body	GG 25 DIN 1691
2.1 Lower Valve Ring	Graphite T1
2.2 Upper Valve Ring	Graphite T4
3 Lantern Bush	Carbon Steel / GG 25 DIN 1691 ★
4 Piston	ASTM A582 - XM 34 ★ G-X 70 Cr Mo 29 2 ★
5 Split Nut	● Fe37 + H.T.
6 Spindle	C30
7 Handwheel	Carbon Steel
8 Handwheel Nut	5-2
9 Bonnet	GG 25 DIN 1691
10 Stud Bolt and Nut	5.6 - 5-2
11 Belleville Washer	50 Cr V4
41 Thrust Plate	■ AISI 420 H.T.
50 Name Plate	Aluminium

● not existing for DN 15, 20, 25 mm

★ depending upon Size  
 ■ for Size 40 and larger, only

# BONETTI® Piston Valves – Steel

**Stop Valves, Reduced Bore, Type BVR**  
**Flanged Ends to DIN 2545 - PN 40**  
**Rating: DIN 2401 - PN 40**  
**Size DN 15 to DN 50**

- 1 Standard Flanges are Raised Face, drilled.
- 2 On request instead of Raised Face flanges can have following finishings:
  - large female to DIN 2513
  - groove to DIN 2512
- 3 Face-to-Face Dimension (A) to DIN 3202 - F1.
- 4 Standard Material Schedules: FS - PN 40, F - PN 40, M/H - PN 40.
- 5 Pressure - Temperature Rating on page 2.

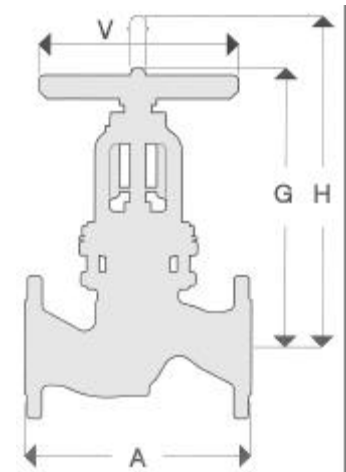

Fig. 1076

Type	DN mm	Fig.	Mater. Sched.	Dimensions				Flange Dimensions					Weight kg	Valve Rings (see page 20)		
				A mm	G mm	H mm	V mm	Outs. Dia. mm	Thick. mm	No. of Holes No.	Dia. of Holes mm	Dia. of Bolt Circle mm		d mm	D mm	h mm
BVR	15	1076	FS - M/H	130	90	108	75	95	16	4	14	65	2,6	10	18	6
BVR	20	1076	FS - M/H	150	110	140	95	105	18	4	14	75	3,8	15	23,5	9
BVR	25	1076	F - M/H	160	135	170	115	115	18	4	14	85	5,3	20	30	10
BVR	32	1076	F - M/H	180	150	185	125	140	18	4	18	100	8,3	25	38	12
BVR	40	1076	F - M/H	200	170	210	150	150	18	4	18	110	10,2	30	45	15
BVR	50	1076	F - M/H	230	195	250	150	165	20	4	18	125	14,0	40	58	16

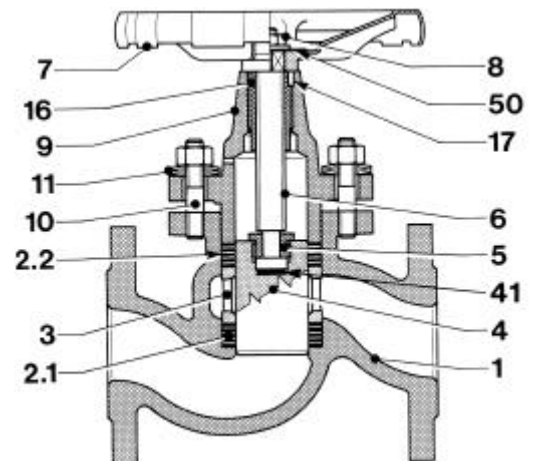

Fig. 1076

Part	Part Material for Material Schedule	
	FS - F	M/H
1 Body	C22.8 ★ GS - C 25 ★	X5 Cr Ni Mo 17 22 2 ★ G - X6 Cr Ni Mo 18 10 ★
2.1 Lower Valve Ring	Graphite T1	Graphite T1
2.2 Upper Valve Ring	Graphite T1	Graphite T1
3 Lantern Bush	Carbon Steel. / GG 25 ★	X5 Cr Ni Mo 17 22 2
4 Piston	ASTM A582 - XM 34	X5 Cr Ni Mo 17 22 2
5 Split Nut	● Fe37 + H.T.	Fe37 + H.T.
6 Spindle	A479 Tp410	A479 Tp410
7 Handwheel	Carbon Steel	Carbon Steel
8 Handwheel Nut	5-2	5-2
9 Bonnet	C22.8 / ASTM A105	C22.8 / ASTM A105
10 Stud Bolt and Nut	5.6 - 5-2	5.6 - 5-2
11 Belleville Washer	50 Cr V4	50 Cr V4
16 Threaded Bush	▲ OT 58	ASTM A439 D2
17 Pin	▲ Carbon Steel	Carbon Steel
41 Thrust Plate	■ AISI 420 H.T.	AISI 420 H.T.
50 Name Plate	Aluminium	Aluminium

● not existing for DN 15, 20, 25 mm

★ depending upon Size

▲ for Size 40 and larger only

■ for Size 40 and larger, only



# BONETTI® Piston Valves – Steel

## Stop Valves – Flanged Ends to ASME B16.5 - 150 lb Rating: ASME Class 150 – Size 1/2" to 6"

- 1 Flanges are according to ASME/ANSI B16.5 - 1988 Class 150 lb, Raised Face, drilled.
- 2 Face-to-Face Dimension (A) to ASME/ANSI B16.10 - 1986.
- 3 Standard Material Schedules: FS - 150 lb, F - 150 lb, M/H - 150 lb.
- 4 Pressure - Temperature Rating on page 2.
- 5 Valves sized up to 2" are made according to Fig. 1053. Valves sized 3" and larger are made to Fig. 1023 namely Type BVe, with balanced piston and rising nonrotating stem.

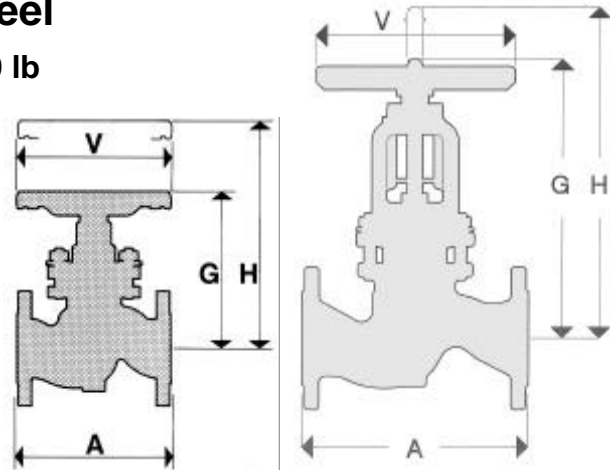

Fig. 1053

Fig. 1023

Type	DN inches	Fig.	Mater. Sched.	Dimensions				Flange Dimensions					Weight kg	Valve Rings (see page 20)			Stuffing-box Rings (see page 20)		
				A	G	H	V	Outs. Dia.	Thick.	No. of Holes	Dia. of Holes	Dia. of Bolt Circle		d	D	h	d	D	h
				mm	mm	mm	mm	mm	mm	No.	mm	mm	kg	mm	mm	mm	mm	mm	mm
BV	1/2"	1053	FS - M/H	108	108	134	95	89,0	11,2	4	16	60,3	2,0	15	23,5	9	=	=	=
BVR	3/4"	1053	FS - M/H	117	108	134	95	98,5	12,7	4	16	69,9	2,5	15	23,5	9	=	=	=
BVR	1"	1053	FS - M/H	127	133	165	115	108,0	14,3	4	16	79,4	4,2	20	30	10	=	=	=
BVR	1.1/2"	1053	F - M/H	165	170	212	150	127,0	17,5	4	16	98,4	8,7	30	45	15	=	=	=
BVR	2"	1053	F - M/H	203	194	245	150	152,0	19,0	4	19	120,0	13,8	40	58	16	=	=	=
BVe	3"	1023	F - M/H	241	375	435	250	190,0	24,0	4	19	152,0	40,0	70	94	19	20	30	10
BVe	4"	1023	F - M/H	292	415	490	300	230,0	24,0	8	19	190,0	50,0	90	112	20	20	30	10
BVe	6"	1023	F - M/H	406	495	590	350	280,0	25,0	8	22	241,0	98,0	130	155	23	25	38	12

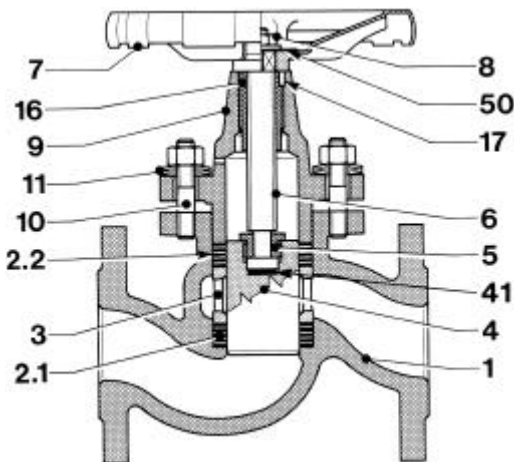

Fig. 1053

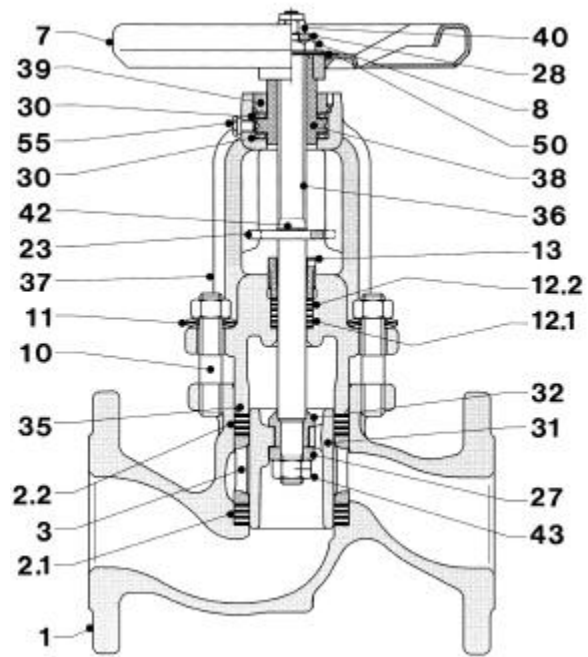

Fig. 1023

Part	Part Material for Material Schedule	
	FS - F	M/H
1 Body	ASTM A105 ★ ASTM A216 WCB ★	ASTM A182 F316 ★ ASTM A351 CF8M ★
2.1 Lower Valve Ring	Graphite T1	Graphite T1
2.2 Upper Valve Ring	Graphite T1	Graphite T1
3 Lantern Bush	GG 25 DIN 1691	ASTM A182 F316
4 Piston	ASTM A582 - XM 34	ASTM A479 T.316
5 Split Nut	Fe37+H.T.	Fe37+H.T.
6 Spindle	ASTM A479 T.410	ASTM A479 T.410
7 Handwheel	Carbon Steel	Carbon Steel
8 Handwheel Nut	5	5
9 Bonnet	ASTM A105 / C22.8	ASTM A105 / C22.8
10 Stud Bolt and Nut	A193 B7 - A194 2H	A193 B7 - A194 2H
11 Belleville Washer	50 Cr V4	50 Cr V4
12.1 Stuff.-box Lower Ring	Graphite T1	Graphite T1
12.2 Stuff.-box Upper Ring	Graphite T1	Graphite T1
13 Gand Nut	Carbon Steel	Stainless Steel
16 Threaded Bush	▲ ASTM A439 D2	ASTM A439 D2
17 Pin	▲ Carbon Steel	Carbon Steel
27 Nonrotating Disc	Carbon Steel	ASTM A182 F316
28 Locking Washer	ASTM A182 F6	ASTM A182 F6
30 Roller Bearing	Alloy Steel	Alloy Steel
31 Balanced Piston	ASTM A582 - XM 34	ASTM A351 CF8M
32 Backseat	ASTM A182 F6	ASTM A182 F316
35 Autoseal Ring	Graphite T3	Graphite T3

Part	Part Material for Material Schedule	
	FS - F	M/H
36 Stem	ASTM A479 T.410 c.3	ASTM A564 T.630
37 Bonnet	ASTM A216 WCB	ASTM A351 CF8M
38 Stem Bush	ASTM A439 D2 / GGG NiCr	ASTM A439 D2 / GGG NiCr
39 Retaining Nut	Carbon Steel	Carbon Steel
40 Nut	Carbon Steel	Carbon Steel
41 Thrust Plate	■ AISI 420 H.T.	AISI 420 H.T.
42 Retaining Ring	C. Steel + ENP	C. Steel+ENP
43 Notched Nut	Carbon Steel	Stainless Steel T.316
50 Name Plate	Aluminium	Aluminium
55 Lubricator	1/8" BSP	1/8" BSP

● not existing for DN 1/2", 3/4", 1"  
▲ for DN 1.1/2" and 2" only

★ depending upon Size  
■ for DN 1.1/2" and 2" only





# BONETTI® Piston Valves – Steel

## Stop Valves – Flanged Ends to ASME B16.5 - 300 lb Rating: ASME Class 300 – Size 1/2" to 6"

- 1 Flanges are according to ASME/ANSI B16.5 - 1988 Class 300 lb, Raised Face, drilled
- 2 Face-to-Face Dimension (A) to ASME/ANSI B16.10 - 1986.
- 3 Standard Material Schedules: FS - 300 lb, F - 300 lb, M/H - 300 lb.
- 4 Pressure - Temperature Rating on page 2.
- 5 Valves sized up to 2" are made according to Fig. 1039. Valves sized 3" and larger are made to Fig. 1024 namely Type BVd, with balanced piston and rising nonrotating stem.

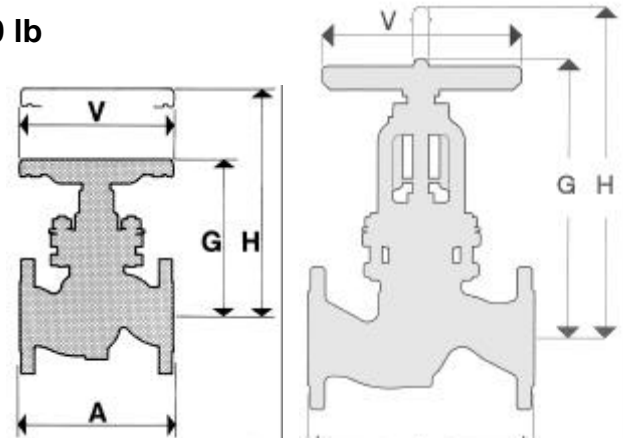

Fig. 1039

Fig. 1024

Type	DN inches	Fig.	Mater. Sched.	Dimensions				Flange Dimensions			Weight kg	Valve Rings (see page 20)			Stuffing-box Rings (see page 20)				
				A	G	H	V	Outs. Dia.	Thick.	No. of Holes		Dia. of Holes	Dia. of Bolt Circle	d	D	h	d	D	h
BV	1/2"	1039	FS - M/H	152	110	140	95	95	14	4	16	67	2,7	15	23,5	9	=	=	=
BV	3/4"	1039	FS - M/H	178	135	170	115	118	16	4	19	83	4,6	20	30	10	=	=	=
BV	1"	1039	FS - M/H	203	150	185	115	124	18	4	19	89	7,0	25	38	12	=	=	=
BV	1.1/2"	1039	F - M/H	228	195	250	150	155	21	4	22	114	14,0	40	58	16	=	=	=
BV	2"	1039	F - M/H	267	225	285	200	165	22	8	19	127	19,0	50	70	17	=	=	=
BVd	3"	1024	F - M/H	317	375	455	300	210	29	8	22	168	50,0	80	105	20	25	38	12
BVd	4"	1024	F - M/H	356	420	515	350	255	32	8	22	200	67,0	100	130	22	30	45	15
BVd	6"	1024	F - M/H	445	530	655	400	318	37	12	22	270	125,0	150	180	28	30	45	15

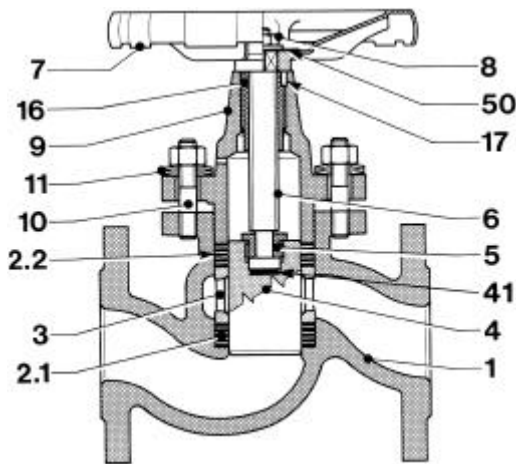

Fig. 1039

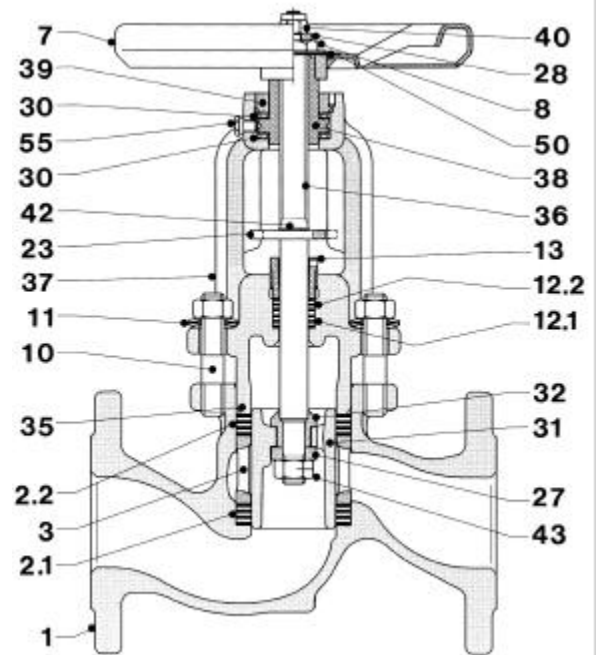

Fig. 1024

Part	Part Material for Material Schedule	
	FS - F	M/H
1 Body	ASTM A105 ★ ASTM A216 WCB ★	ASTM A182 F316 ★ ASTM A351 CF8M ★
2.1 Lower Valve Ring	Graphite T1	Graphite T1
2.2 Upper Valve Ring	Graphite T1	Graphite T1
3 Lantern Bush	GG 25 DIN 1691	ASTM A182 F316
4 Piston	ASTM A582 - XM 34	ASTM A479 T.316
5 Split Nut	Fe37+H.T.	Fe37+H.T.
6 Spindle	ASTM A479 T.410	ASTM A479 T.410
7 Handwheel	Carbon Steel	Carbon Steel
8 Handwheel Nut	5	5
9 Bonnet	ASTM A105 / C22.8	ASTM A105 / C22.8
10 Stud Bolt and Nut	A193 B7 - A194 2H	A193 B7 - A194 2H
11 Belleville Washer	50 Cr V4	50 Cr V4
12.1 Stuff-box Lower Ring	Graphite T1	Graphite T1
12.2 Stuff-box Upper Ring	Graphite T1	Graphite T1
13 Gand Nut	Carbon Steel	Stainless Steel
16 Threaded Bush	ASTM A439 D2	ASTM A439 D2
17 Pin	Carbon Steel	Carbon Steel
23 Antirotating Device	Carbon Steel	Stainless Steel
27 Nonrotating Disc	Carbon Steel	ASTM A182 F316
28 Locking Washer	ASTM A182 F6	ASTM A182 F6
30 Roller Bearing	Alloy Steel	Alloy Steel
31 Balanced Piston	ASTM A582 - XM 34	ASTM A351 CF8M
32 Backseat	ASTM A182 F6	ASTM A182 F316
35 Autoseal Ring	Graphite T3	Graphite T3

Part	Part Material for Material Schedule	
	FS - F	M/H
36 Stem	ASTM A479 T.410 c.3	ASTM A564 T.630
37 Bonnet	ASTM A216 WCB	ASTM A351 CF8M
38 Stem Bush	ASTM A439 D2 / GGG NiCr	ASTM A439 D2 / GGG NiCr
39 Retaining Nut	Carbon Steel	Carbon Steel
40 Nut	Carbon Steel	Carbon Steel
41 Thrust Plate	AISI 420 H.T.	AISI 420 H.T.
42 Retaining Ring	C. Steel + ENP	C. Steel+ENP
43 Notched Nut	Carbon Steel	Stainless Steel T.316
50 Name Plate	Aluminium	Aluminium
55 Lubricator	1/8" BSP	1/8" BSP

● not existing for DN 1/2", 3/4"  
▲ for DN 1.1/2" and 2" only

★ depending upon Size  
■ for DN 1.1/2" and 2" only

# BONETTI® Actuated Piston Valves

All BONETTI® piston valves can be equipped for remote control with:

- electric actuators
- pneumatic actuators
- hydraulic actuators.

## Electrically Actuated Valves (Fig. 1206)

Type "on-off", "inching" and "modulating" electric actuators, tight-seal or explosionproof pattern can be installed on piston valves. These actuators are usually equipped with handwheel for emergency manual operation as well as with control and remote warning unit.

Upon request we supply the following fixtures:

- local remote inverter,
- ancillary limit switches,
- anticondensing resistor,
- inductive, capacitive or resistive position transmitter.

The temperature ambient range for the electric actuator is usually -20°C to +65°C.

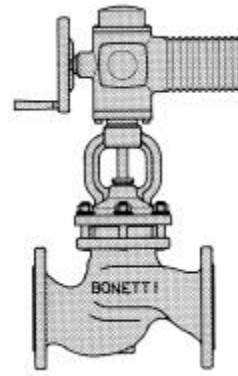

Fig. 1206

## Pneumatically Actuated Valves (Fig. 1207)

Single or double acting pneumatic actuators can be installed on piston valves; single-acting actuators are of two types: "fail-closed" or "fail-open".

Upon request we supply the following fixtures:

- handwheel for emergency manual operation with by-pass circuit for
- double-acting actuators,
- solenoid valves,
- mechanical or proximity limit switches,
- air filters, pressure regulators, pressure gauges, lubricator,
- pneumatic or electropneumatic positioner for Modulating Flow Control Valves.

The temperature ambient range for the pneumatic actuators is usually -20°C to +65°C.

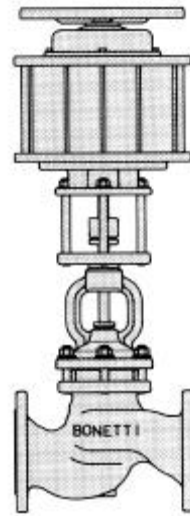

Fig. 1207

## Hydraulically Actuated Valves (Fig. 1208)

Single or double acting hydraulic actuators can be installed on piston valves; single-acting actuators are of two types "fail-closed" or "fail-open".

The hydraulic fluid shall be supplied by a suitable pump, provided by us.

Upon request we supply the following fixtures:

- handwheel for emergency manual operation with by-pass circuit for double-acting actuators,
- solenoid valves,
- mechanical or proximity limit switches,
- electronic positioner with position transmitter, if required, for Modulating Flow Control Valves.

The temperature ambient range for the hydraulic actuators is usually -20°C to +65°C.

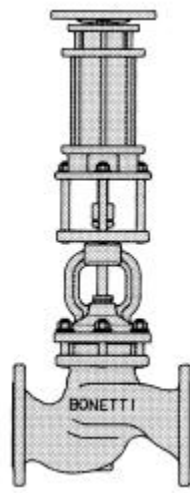

Fig. 1208

## Modulating Flow Control Valves

Piston valves are mostly used as "On-Off" Globe Valves.

As already said on page 3, our valves are suitable for use as Modulating Valves.

The flow path of BONETTI® Piston Valves is excellent for control of flow rate too, even with the standard lantern bush, a component which basically is not designed for flow control.

The Modulating Flow Control Pattern is fitted with multihole lantern bush having an equal-percentage characteristic (upon request: linear or quick opening).

We would point out:

- the Flow Control Pattern is tight sealed, when closing, like all BONETTI® Piston Valves, therefore it is not necessary to fit additional shutoff valves;
- even with high pressure differential, our Piston Flow Control Valves do not cause vibrations/noise thanks to their perfectly guided piston - contrary to the control valves with contoured plug.

Our Piston Modulating Valves are equipped with actuators operated by means of signals coming from process controllers.

In order to submit a correct quotation, the special data sheets produced by us should be filled up.

In many cases following data are enough:

- kind of fluid
- upstream and downstream pressure
- operating pressure
- flow rate
- type of controlling signal.

# Flow Coefficient

On theoretical and experimental elements some equations have been fixed which enable the correlation, each given valve, of flow rate with pressure drop depending on kind of fluid, inlet pressure and temperature.

These equations show a parameter, constant within some limits, depending exclusively on type and dimensions of valve and obtained by means of laboratory tests. This parameter is valid for the whole series of equal valves and for all operating conditions.

This parameter, known as **Flow Coefficient**, corresponds to the volume of water under standard conditions flowing through a valve under a unit pressure drop.

In consideration of the different present unit system as well as of the dimensional and nondimensional factors which have been applied in order to get numerical values, practical for calculations, there are various measurement units for flow coefficient and further factors to introduce into calculating formulas for the various derivating combinations.

Here we report the definitions of the Flow Coefficients most frequently used to select the valve size:

**Cv (American Flow Coefficient)** is the volume of water at 40-100°F in American Gallons per minute which flows through a valve, in the full open position, under 1 psi pressure differential.

**Kv (European Flow Coefficient)** is the volume of water at 5-40°C in Cubic Meters per hour which flows through a valve, in the full open position, under 1 bar pressure differential.

## Flow Coefficient for Stop Valves

DN	Fig.	Cv (Kv)	Fig.	Cv (Kv)
10 3/8"		3,5 (3,5)		
15 1/2"	1010 , 1018	5 (4,5)		
20 3/4"	1039 , 1053	10 (8,5)		
25 1"	1075 , 1076	16 (14,0)		
32 1.1/4"	1077 , 1078	24 (20,5)		
40 1.1/2"	1079 , 1080	38 (32)		
50 2"		58 (50)		
65 2.1/2"		82 (70)		95 (82)
80 3"	1045	120 (105)	1024	150 (130)
100 4"	1021	190 (165)	1046	220 (190)
125 5"	1022	290 (255)		340 (290)
150 6"	1023	420 (360)		515 (440)
200 8"		690 (590)		

For BVR type Valves, select the Cv and Kv values of a valve having nominal bore (DN) one size smaller.

## Flow Coefficient for Flow Control Valves

DN	Fig.	Cv (Kv)	Fig.	Cv (Kv)
10 3/8"		4 (3,5)		
15 1/2"	1010 , 1018	7 (6,0)		
20 3/4"	1039 , 1053	12 (10,5)		
25 1"	1075 , 1076	18 (15,5)		
32 1.1/4"	1077 , 1078	28 (24)		
40 1.1/2"	1079 , 1080	44 (38)		
50 2"		62 (53)		75 (65)
65 2.1/2"		92 (79)		115 (100)
80 3"	1045	140 (120)	1024	210 (180)
100 4"	1021	220 (190)	1046	260 (220)
125 5"	1022	300 (260)		360 (310)
150 6"	1023	510 (440)		
200 8"				

For BVR type Valves, select the Cv and Kv values of a valve having nominal bore (DN) one size smaller.

# BONETTI®

The dimensions of the rings fitted in each valve are indicated in the last columns on the right side of each descriptive table.

The Spare Rings are currently precompressed and their height (h dimension) is lower than the value listed on the tables.

1 The patented BONETTI® Piston Valve Rings consist of metall alloys reinforced lamellar graphite. Their composition, design and manufacturing have been fixed after a long testing period in laboratories and on plants.

The main features of these rings are as follows:

- durable perfect tightness,
- resistance to temperatures up to 550°C,
- resistance to etching of process fluids,
- practically one valve ring type for all fluids. No confusion and reduction of stock,
- low friction coefficient and consequently valve operation with low torques,
- no need of bolts re-tightening during service,
- longer duration than asbestos rings, therefore maintenance-free.

2 For one Piston Valve Fig. 1071 (with non balanced piston) one complete kit of rings consists of:

- 2 Rings (item 2.1 and 2.2) of Reinforced Lamellar Graphite (Fig. 1001).

3 For one Piston Valve Fig. 1072 (with balanced piston) one complete kit of rings consists of:

- 2 Rings (item 2.1 and 2.2) of Reinforced Lamellar Graphite (Fig. 1001)
- 2 Stuffing-Box Rings (item 12.1 and 12.2)
- 1 Autoseal Ring (item 35 - Fig. 1009)

4 We usually supply kits of valve rings, each consisting of the spare valve rings necessary for the complete replacement in given Valve Type and DN.

5 Upon request and for very special applications we supply PTFE Valve Rings with same dimensions as in Fig. 1063.

The Torques of the bonnet Nuts (Item 10) are listed on the table of Fig. 1063.

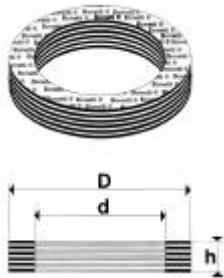
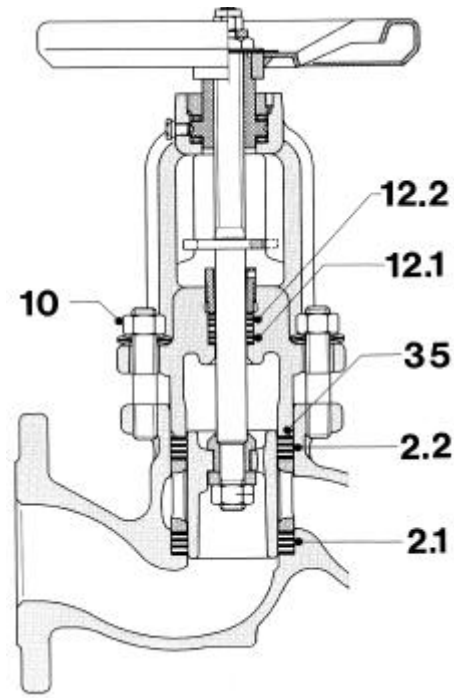
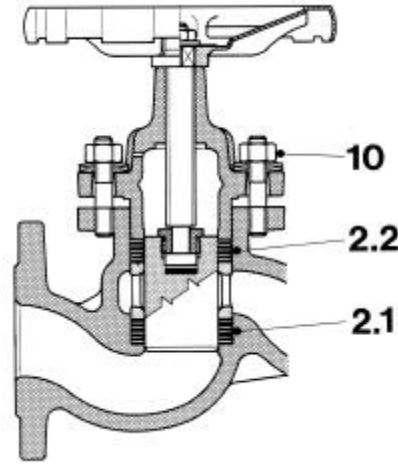

Fig. 1001

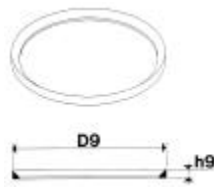

Fig. 1009  
Autoseal Ring

Fig. 1063

Note	For Valve				Dimensions of Rings						Bolting Torque (Note 6)								
											BV - BVR - BVn		BVe		BVd				
	Type	DN	Type	DN	Valve Rings (items 2.1 and 2.2)			Stuffing-box Rings (items 12.1 and 12.2)			Autoseal Ring (item 35)		PN 16 PN 40 150 lb 300 lb	PN 63 800 lb	PN 16	PN 40 150 lb	300 lb		
	mm inches		mm inches	d	D	h	d	D	h	D9	h9	Nm	Nm	Nm	Nm	Nm			
2	BV	10	3/8"	BVR	15	3/8" 1/2"	10	18	6	=	=	=	=	=	3	8			
	BV	15	1/2"	BVR	20	3/4"	15	23,5	9	=	=	=	=	=	3	10			
	BV	20	3/4"	BVR	25	1"	20	30	10	=	=	=	=	=	3	12			
	BV	25	1"	BVR	32	1.1/4"	25	38	12	=	=	=	=	=	3	17			
	BV	32	1.1/4"	BVR	40	1.1/2"	30	45	15	=	=	=	=	=	4	18			
	BV	40	1.1/2"	BVR	50	2"	40	58	16	=	=	=	=	=	5	18			
	BV	50	2"				50	70	17	=	=	=	=	=	5	18			
2	BVn	65					60	82	16	=	=	=	=	=	10				
	BVn	80					70	94	19	=	=	=	=	=	5				
	BVn	100					90	112	20	=	=	=	=	=	5				
	BVn	125					110	135	22	=	=	=	=	=	14				
	BVn	150					130	155	23	=	=	=	=	=	12				
3	BVe	65					60	82	16	20	30	10	82	4,2			12	18	
	BVe	80	3"				70	94	19	20	30	10	94	4,2			8	12	
	BVe	100	4"				90	112	20	20	30	10	112	4,2			8	12	
	BVe	125					110	135	22	25	38	12	135	5,4			18	27	
	BVe	150	6"				130	155	23	25	38	12	155	5,4			16	24	
	BVe	200					170	200	15	25	38	12	200	5,4			40	50	
3	BVd	65/70					70	94	19	25	38	12	94	4,2					-
	BVd	80	3"				80	105	20	25	38	12	105	4,2					14
	BVd	100	4"				100	130	22	30	45	15	130	5,4					14
	BVd	125					125	155	22	30	45	15	155	5,4					-
	BVd	150	6"				150	180	28	30	45	15	180	5,4					28



**Ask for peculiar bulletin of other BONETTI products:**

**G Sleeve packed cocks**

**G Ball valves**

- with actuator,
- for boiler blow down,
- for high temperature (up to 550° C, 1020° F)

**G Bellows seal globe and gate valves for medium and high pressure**

**G CMI-Pasquini globe, gate and check valves, up to 24" and ANSI 4500 lbs.**

- pneumatic actuated check valves, too

**G CMI-Pasquini quick acting automatic 2 and 3-ways valves**

**G Glass level gauges, for any application**

- reflex type
- transparent type
- bicolor type

**G Magnetic level gauge**

- for any application
- of any different material
- with remote indication

**G Remote reading level gauges**

- glass type
- magnetic type



**BONT®**

**BONETTI®**

**CMI PASQUINI**





***IQNet Registration No. IT-3822***

*This is to state that*

**CESARE BONETTI S.p.A.**

**Via Cesare Bonetti, 17**

**I-20024 GARBAGNATE MILANESE (MI)**

*holds the  
Quality System Certificate*

**CISQ/ICIM 0021/2 (valid until 2000-09-20)**

*for the scope specified thereon and for the standard*

**ISO 9001**

*Signed for and on behalf of IQNet*

*Klaus Petrick  
President of IQNet*

1997-09-21

*Date*



*Gianrenzo Prati  
CISQ President*

This document and the underlying certificate are recognized by all IQNet members:

**AENOR Spain AFAQ France AIB-Vinçotte Inter Belgium APCER Portugal BSI-QA United Kingdom  
CISQ Italy DQS Germany DS Denmark ELOT Greece JQA Japan KEMA Netherlands KSA-QA Korea  
NCS Norway NSAI Ireland ÖQS Austria PSB Singapore QAS Australia QMI Canada SFS Finland SII Israel  
SIQ Slovenia SIS Sweden SQS Switzerland**

This document is only valid when presented with the member's certificate above.  
The issuing member indemnifies all other members from any claims arising from the existence of this document.



Conversion Table from °C to °F

°C	°F	°C	°F	°C	°F	°C	°F
-270	-454	165	329	520	968	1100	2012
-260	-436	170	338	525	977	1120	2048
250	-418	17.5	347	530	986	1140	2084
-240	-400	180	356	535	995	1160	2120
230	-382	185	365	540	1004	1180	2156
-220	-364	190	374	545	1013	1200	2192
210	-346	195	383	550	1022	1220	2228
-200	-328	200	392	555	1031	1240	2264
190	-310	205	401	560	1040	1260	2300
-180	-292	210	410	565	1049	1280	2336
170	-274	215	419	570	1058	1300	2372
-160	-256	220	428	575	1067	1320	2408
150	-238	225	437	580	1076	1340	2444
-140	-220	230	446	585	1085	1360	2480
130	-202	235	455	590	1094	1380	2516
-120	-184	240	464	595	1103	1400	2552
110	-166	245	473	600	1112	1420	2588
-100	-148	250	482	605	1121	1440	2624
95	-139	255	491	610	1130	1460	2660
-90	-130	260	500	615	1139	1480	2696
85	-121	265	509	620	1148	1500	2732
-80	-112	270	518	625	1157	1520	2768
-75	-103	275	527	630	1166	1540	2804
-70	-94	280	536	635	1175	1560	2840
-65	-85	285	545	640	1184	1580	2876
-60	-76	290	554	645	1193	1600	2912
-55	-67	295	563	650	1202	1620	2948
50	-58	300	572	655	1211	1640	2984
-45	-49	305	581	660	1220	1660	3020
-40	-40	310	590	665	1229	1680	3056
-35	-31	315	599	670	1238	1700	3092
-30	-22	320	608	675	1247	1750	3182
-25	-13	325	617	680	1256	1800	3272
-20	4	330	626	685	1265	1850	3362
-17,8	0	335	635	690	1274	1900	3452
-15	5	340	644	695	1283	1950	3542
-10	14	345	653	700	1292	2000	3632
-5	23	350	662	710	1310	2050	3722
0	32	355	671	720	1328	2100	3812
5	41	360	680	730	1346	2150	3902
10	50	365	689	740	1364	2200	3992
15	59	370	698	750	1382	2250	4082
20	68	375	707	760	1400	2300	4172
25	77	380	716	770	1418	2350	4262
30	86	385	725	780	1436	2400	4352
35	95	390	734	790	1454	2450	4442
40	104	395	743	800	1472	2500	4532
45	113	400	752	810	1490	2550	4622
50	122	405	761	820	1508	2600	4712
55	131	410	770	830	1526	2650	4802
60	140	415	779	840	1544	2700	4892
65	149	420	788	850	1562	2750	4982
70	158	425	797	860	1580	2800	5072
75	167	430	806	870	1598	2850	5162
80	176	435	815	880	1616	2900	5252
85	185	440	824	890	1634	2950	5342
90	194	445	833	900	1652	3000	5432
95	203	450	842	910	1670		
100	212	455	851	920	1688		
105	221	460	860	930	1706		
110	230	465	869	940	1724		
115	239	470	878	950	1742		
120	248	475	887	960	1760		
125	257	480	896	970	1178		
130	266	485	905	980	1796		
135	275	490	914	990	1814		
140	284	495	923	1000	1832		
145	293	500	932	1020	1868		
150	302	505	941	1040	1904		
155	311	510	950	1060	1940		
160	320	515	959	1080	1976		

Pressure/Temperature Table for Saturated Water Steam

bar	°C
1	99,1
1,5	110,7
2	119,6
2,5	126,7
3	132,8
3,5	138,1
4	142,9
4,5	147,2
5	151,1
5,5	154,7
6	158,0
6,5	161,1
7	164,1
7,5	167,1
8	169,6
8,5	172,2
9	174,5
9,5	176,7
10	179,0
11	183,2
12	187,0
13	190,7
14	194,1
15	197,3
16	200,4
17	203,3
18	206,1
19	208,8
20	211,4
22	216,2
24	220,7
26	225,0
28	228,9
30	232,7
35	241,4
40	249,1
45	256,2
50	262,7
55	268,6
60	274,2
65	279,5
70	284,4
75	289,1
80	293,6
85	297,8
90	301,9
95	305,8
100	309,5
105	313,3
110	316,5
115	319,8
120	323,1
125	326,2
130	329,3
135	332,2
140	335,1
145	337,8
150	340,6
155	343,2
160	345,7
165	348,3
170	350,6
175	353,0
180	355,4
185	357,5
190	359,8
195	361,9
200	364,1
205	366,1
210	368,1
215	370,2
220	372,0
225	374,0

In Milan, in 1905 Cesare Bonetti opened a small shop and manufactured to order any cocks for the local requirement.

In the early twenties this small firm took on a new industrial look and moved towards production and trade of industrial valves only.

Bonetti is, by this time, becoming a well-known company for production of piston valves, sleeve-packed cocks and glass level gauges.

Later the production range, bearing the BONT registered trade-mark includes the new valves for high pressure and temperature meeting the strictest requirements of the most advanced technology, besides double-sealing valves, bellows valves, diaphragm valves, magnetic level gauges.

After two enlargements the company in 1969 moves to the new Garbagnate Milanese Works where Bonetti's

typical trend for research, development and design accuracy has more opportunity to expand.

**Certification according to ISO 9001 / UNI EN 29001.**

Facilities:

Enclosed surface 66,000 sq.m

Offices building (with car parking below) for three stories 2,200 sq.m

Facilities building (mess-hall, locker rooms, sanitary department, etc.) for three stories 2,000 sq.m

Manufacturing shed (including Production Department and general Facilities) 17,500 sq.m



Conec. S/M/A 2839/93

This catalogue is exclusive property of Cesare Bonetti S.p.A. Any unauthorized reproduction, in total or in part, of this catalogue shall be prosecuted. Products and data sheets on this catalogue reflect current standard production. Cesare Bonetti S.p.A. reserves the right to carry out amendments to products and materials.

Amendments or modifications to drawings and materials can be done also to comply with particular Customer's request or technical specifications.

## Branch Offices in Foreign Countries

<b>Germany</b>	<b>Bonetti Armaturen GmbH</b>	In den Fritzenstücker 4 - D 65549 LIMBURG / LAHN Tel. (06431) 7 20 41 Fax (06431) 7 20 66
<b>Australia - New Zealand</b>	<b>Bonetti Australia Pty Ltd</b>	136 Union Street (P.O. Box 170) BRUNSWICK, 3056 (Australia) Tel. (03) 3874311 - Fax (03) 3880698

Ask for information about our International Network of Technical Sale Representatives.



# CESARE BONETTI S.p.A.

I 20024 GARBAGNATE MILANESE (Italy)  
Via Cesare Bonetti 17

Telephone: +39 -029956462 -029957261 -029958313 -0299072.1  
Telex: 330080 BONET I - Telefax: +39-029952483  
Internet: <http://www.cesare-bonetti.it>  
E-mail: [bont.post@cesare-bonetti.it](mailto:bont.post@cesare-bonetti.it)