

Performance Specifications Table

Nominal pressure Class	6000PSI	
Body testing	62.1	MPa
Seal testing	45.5	
Operating temperature		
Applicable media:	water, Steam, Oil, Power Station	

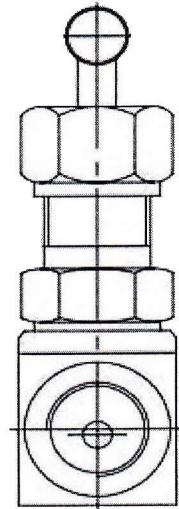
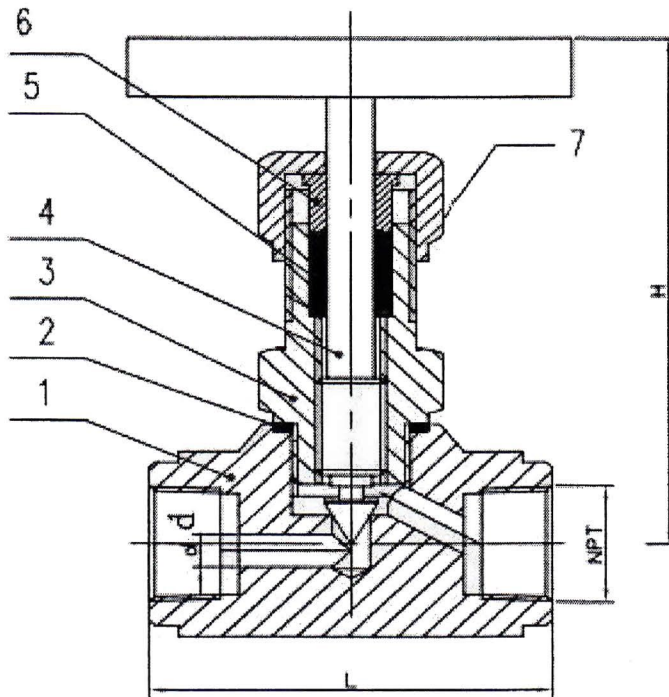

NOTES:

- 1.THREADED END:ASME B1.20.1-1983,
- 2.DESIGNED BY:ASME B16.34;
- 3.TESTED AND CHECKED BY:API 598;
- 4.FACE TO FACE END:DIN3202 M4-1994.

7	GLAND NUT	A182 F316
6	GLAND	A182 F316
5	PACKING GLAND	GRAPHITE
4	PACKING GASKET	A182 F316
3	CAP	A182 F316
2	GASKET	GRAPHITE
1	BODY	A182 F316

DIMENSION LIST

NPS	d	G	L
1/4"	5	1/4"-18NPT	54
3/8"	5	3/8"-18NPT	56
1/2"	6	1/2"-14NPT	63
3/4"	7	3/4"-14NPT	70
1"	10	1"-11.5NPT	90
1-1/4"	13	1-1/4"-11.5NPT	93
1-1/2"	18	1-1/2"-11.5NPT	103
2"	22	2"-11.5NPT	131

NO	PART NAME	MATERIAL
----	-----------	----------

ST400 NPT S316 (GR)