



# Table of Contents

---

## Mann-Tek design

Dry Disconnect.....	4 - 5
Dry Aviation.....	6 - 7
Dry Gas.....	8 - 9
Ratings & Options.....	10 - 11

## Cam & Groove design

Dry Disconnect.....	12 - 15
Actuator style.....	26

## Bayonet design

Dry Disconnect.....	16 - 17
---------------------	---------

## Safety Break-Aways

Industrial version (breaking bolt design).....	18 - 19
Marine version (breaking bolt design).....	20 - 21
Connection combinations & Options.....	22 - 23
How it works.....	24
Ratings & Kits.....	24 - 25

## API fittings

Coupler.....	27
--------------	----

---

## Hose Coupling Safety

- Use Dixon couplings, retention devices and accessory products only for their intended service.
- All recommendations of the Hose Manufacturer, and the Coupling Manufacturer, must be employed with regards to Size, Temperature, Application, Media, and Pressure when selecting the components for a hose assembly.
- All finished hose assemblies should be tested in accordance with the Rubber Manufacturers Association recommendations.
- All hose assemblies should be thoroughly inspected prior to each use to ensure they are undamaged, and properly coupled.
- Use safety clips on couplings, and King Safety Cables on assemblies where required by the manufacturer, as well as State and Federal regulations. (OSHA regulations may be viewed in full on the OSHA website, [www.osha.gov](http://www.osha.gov).)
- Under no circumstances should the assembly working pressure or working temperature exceed the working pressure or working temperature of the lowest rated component (coupling, clamp, ferrule, or hose).
- Call Dixon (800.355.1991) for advice on couplings, retention devices, and accessories for your application.

## Features & Benefits

Dry disconnect couplings are designed for the quick and spill free connection and disconnection of hoses and pipelines when transferring expensive hazardous product that is costly to clean up, reprocess or dispose of. Dry disconnects are used by producers of ink, adhesives, fatty acids, pharmaceuticals, liquid soaps, petroleum, chemicals, agricultural and a wide variety of common caustic and specialty acids.



- easy to handle - push and turn - free flow, turn and pull - closed
- time saving - no need to drain hoses or pipe systems
- economical - no loss or spillage of liquids at connection or disconnection
- safety - the valve cannot be opened until the unit is coupled
- environment friendly - accidental spillage eliminated when properly used
- safe and reliable - due to rugged construction
- product life - uncomplicated design and high quality materials ensures long product life
- selectivity - To avoid product contamination caused by connecting a coupler to the wrong adapter, selective versions of the adapters are available. Contact the factory for further information.
- produced according to NATO standard STANAG 3756 and ATOFINA SGM 2049.TUY.C.
- compatible with Mann-Tek, Avery Hardoll and Todo-matic® and any other product produced according to NATO standard STANAG 3756
- Working Pressure -
  - aluminum: **300 PSI** up to 4"
  - brass/ gunmetal \*: **300 PSI** up to 4"
  - stainless steel: **360 PSI**
- Optional seals:
  - EPDM
  - NBR - nitrile
  - Kalrez®
  - Chemraz®
  - Perlast®

\* produced to U.S. government bronze specification G

## How It Works

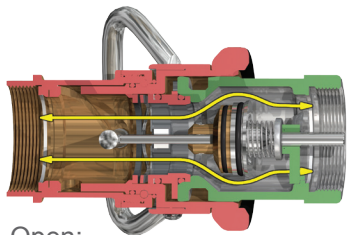

Open:

- Push and turn  
it's coupled - full flow

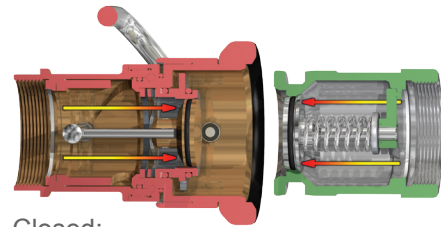

Closed:

- Turn and pull  
it's released - no spillage

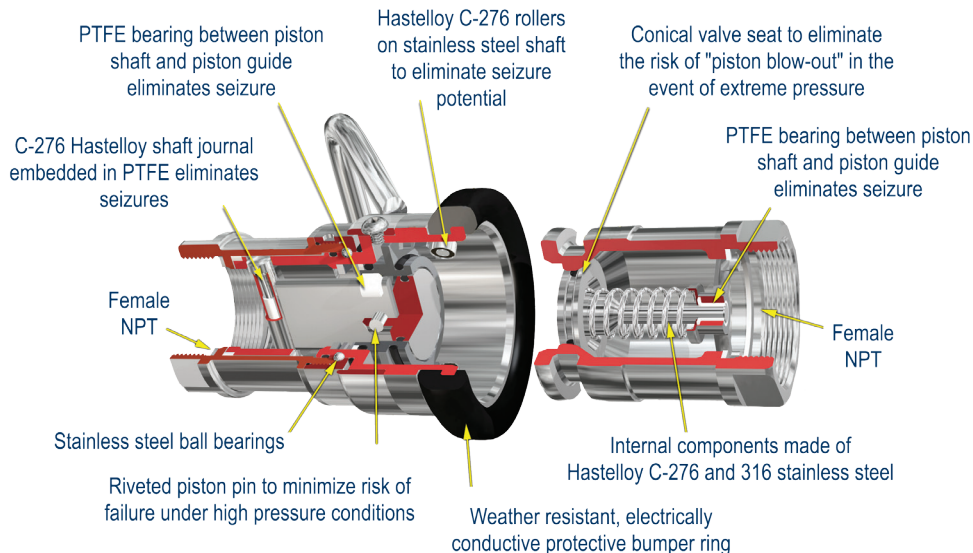

DDC200SS pictured

## Dry Disconnects Coupler - Hose Unit



female NPT x coupler - aluminum  
¾" and 1" design



female NPT x coupler - brass  
1½" and 2" design



female NPT x coupler - stainless steel  
3" design



female NPT x coupler - aluminum  
4" design

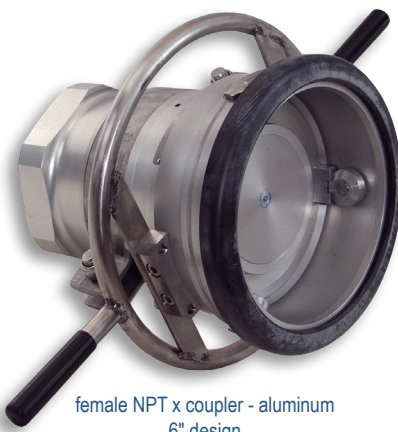

female NPT x coupler - aluminum  
6" design

- coupler has built-in swivel
- stainless steel ball bearings
- shaft journal is stainless steel embedded in PTFE to eliminate seizure
- riveted piston pin to minimize the risk for failure under extreme pressure conditions
- the protective ring is a specially formulated, weather resistant and electrically conductive rubber compound
- stainless steel couplers: rollers are Hastelloy C276 on the stainless steel shaft
- aluminum and brass couplers: rollers are aluminum-bronze on the stainless steel shaft
- for information on repair kits visit us on-line at [www.dixonvalve.com](http://www.dixonvalve.com)

### dry quick disconnect couplers x female NPT with Viton® seals

Female NPT	Body Size	316 Stainless Steel	Anodized Aluminum	Brass / Gunmetal *
¾"	56 mm	<b>DDC075SS</b>	<b>DDC075AL</b>	<b>DDC075BR</b>
1"	56 mm	<b>DDC100SS</b>	<b>DDC100AL</b>	<b>DDC100BR</b>
1½"	70 mm	<b>DDC150SS</b>	<b>DDC150AL</b>	<b>DDC150BR</b>
2"	70 mm	<b>DDC200SS</b>	<b>DDC200AL</b>	<b>DDC200BR</b>
3"	105 mm	<b>DDC300SS105</b>	<b>DDC300AL105</b>	<b>DDC300GM105</b>
3"	119 mm	<b>DDC300SS</b>	<b>DDC300AL</b>	<b>DDC300GM</b>
4"	164 mm	<b>DDC400SS</b>	<b>DDC400AL</b>	<b>DDC400GM</b>
6"	238 mm	<b>DDC600SS</b>	<b>DDC600AL</b>	---

\* produced to U.S. government bronze specification G

### Dust Plugs for Couplers



composite plug

- Composite (Polyeten PE-HD 300) plugs provide good protection against corrosion and withstands hot and cold environments.

Size	Body Size	Polyeten PE-HD 300
¾" and 1"	56 mm	<b>DDDP075</b>
1½" and 2"	70 mm	<b>DDDP150</b>
3"	105 mm	<b>DDDP300105</b>
3"	119 mm	<b>DDDP300</b>
4"	164 mm	<b>DDDP400</b>
6"	238 mm	<b>DDDP600</b> <sup>1</sup>

<sup>1</sup> 6" dust plug is aluminum

## Dry Disconnects Tank Unit

- adapter is usually installed on the tank or manifold
- conical valve seat reduces the risk for "piston blow out"
- PTFE bearings between the piston shaft and the piston guide eliminate the risk for seizure
- for information on repair kits visit us on-line at [www.dixonvalve.com](http://www.dixonvalve.com)

### dry quick disconnect adapters x female NPT with Viton® seals

Female NPT	Body Size	316 Stainless Steel	Anodized Aluminum	Brass / Gunmetal *
¾"	56 mm	<b>DDA075SS</b>	<b>DDA075AL</b>	<b>DDA075BR</b>
1"	56 mm	<b>DDA100SS</b>	<b>DDA100AL</b>	<b>DDA100BR</b>
1½"	70 mm	<b>DDA150SS</b>	<b>DDA150AL</b>	<b>DDA150BR</b>
2"	70 mm	<b>DDA200SS</b>	<b>DDA200AL</b>	<b>DDA200BR</b>
3"	105 mm	<b>DDA300SS105</b>	<b>DDA300AL105</b>	<b>DDA300GM105</b>
3"	119 mm	<b>DDA300SS</b>	<b>DDA300AL</b>	<b>DDA300GM</b>
4"	164 mm	<b>DDA400SS</b>	<b>DDA400AL</b>	<b>DDA400GM</b>
6"	238 mm	<b>DDA600SS</b>	<b>DDA600AL</b>	---

\* produced to U.S. government bronze specification G

### dry quick disconnect adapters x 150# ASA flange with Viton® seals

150# ASA	Body Size	316 Stainless Steel	Anodized Aluminum	Brass / Gunmetal *
¾"	56 mm	<b>DDA075SSFL</b>	---	---
1"	56 mm	<b>DDA100SSFL</b>	<b>DDA100ALFL</b>	<b>DDA100BRFL</b>
1½"	70 mm	<b>DDA150SSFL</b>	<b>DDA150ALFL</b>	<b>DDA150BRFL</b>
2"	70 mm	<b>DDA200SSFL</b>	<b>DDA200ALFL</b>	<b>DDA200BRFL</b>
3"	105 mm	<b>DDA300SS105FL</b>	<b>DDA300AL105FL</b>	<b>DDA300GM105FL</b>
3"	119 mm	<b>DDA300SSFL</b>	<b>DDA300ALFL</b>	<b>DDA300GMFL</b>
4"	164 mm	<b>DDA400SSFL</b>	<b>DDA400ALFL</b>	<b>DDA400GMFL</b>
6"	238 mm	<b>DDA600SSFL</b>	<b>DDA600ALFL</b>	---

\* produced to U.S. government bronze specification G

### dry quick disconnect adapters x TTMA flange with Viton® seals

TTMA	Body Size	Anodized Aluminum
3"	105 mm	<b>DDA300AL105TTMA</b>
3"	119 mm	<b>DDA300AL119TTMA</b>
4"	164 mm	<b>DDA400AL164TTMA</b>

#### Construction:

- aluminum adapter - aluminum poppet, stainless steel internal parts
- stainless steel adapter - stainless steel poppet, stainless steel internal parts
- brass / gunmetal \* adapter - brass poppet, brass and stainless steel internal parts

\* produced to U.S. government bronze specification G



adapter x female NPT - DDA100BR

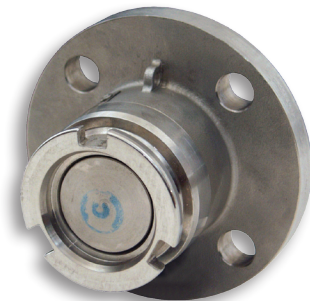

adapter x 150# ASA flange - DDA200SSFL

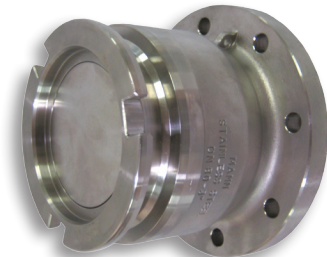

adapter x TTMA flange - DDA300AL119TTMA

## Dust Caps for Adapters

- Composite (Polyeten PE-HD 300) caps provide good protection against corrosion and withstands hot and cold environments.

### dust caps for adapters

Size	Body Size	Polyeten PE-HD 300	Rubber
¾" and 1"	56 mm	<b>DDDC075</b>	---
1½" and 2"	70 mm	<b>DDDC150</b>	<b>DGDC200</b>
3"	105 mm	<b>DDDC300105</b>	<b>DGDC300</b>
3"	119 mm	<b>DDDC300</b>	---
4"	164 mm	<b>DDDC400</b>	---
6"	238 mm	<b>DDDC600</b> <sup>1</sup>	---

<sup>1</sup> 6" dust cap is aluminum



composite cap



rubber cap

# Dry Aviation Couplings

## Hose Unit

Dry aviation couplings are designed for use in aviation refueling systems. Manufactured to accept the international standard 2½" point bayonet, hose end refueling nozzles according to: ISO45 / MS24484 / STANAG 3105 / British Aerospace Spec. 2C14. **They are not configured for under-wing refueling.**

### Technical Information:

- body: high strength aluminum
- coupling ring: gunmetal
- bayonet flange and inner parts: stainless steel, aluminum
- all wetted parts are aluminum and stainless steel
- **150 PSI** working pressure
- stainless steel ball bearings
- gunmetal (*produced to U.S. government bronze specification G*) coupling ring minimizes the risk of seizure
- stainless steel shaft journal embedded in PTFE eliminates seizure
- PTFE bearings between the driving plate and the piston guide eliminate the risk of seizure
- riveted piston pin minimizes the risk of failure under extreme pressure conditions
- the protective ring is a specially formulated, weather resistant and electrically conductive rubber compound



female NPT x coupler - DAC250AL

### aviation couplers x female NPT with Viton® seals

Female NPT	Body Size	Aluminum
2½"	ISO 45	<b>DAC250AL</b>
3"	ISO 45	<b>DAC300AL</b>

### aviation couplers x female BSP with Viton® seals

Female BSP	Body Size	Aluminum
2½"	ISO 45	<b>DAC250ALBSP</b>
3"	ISO 45	<b>DAC300ALBSP</b>

## Sight Flow Indicators

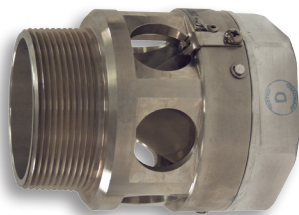

sight flow indicator - ASFI25T25B

- filter / screen can be inspected through the sight glass
- filter / screen is easily removed if cleaning is required
- screen is 100 mesh

### aviation sight flow indicator with filter / screen

Female Thread	Male Thread	Aluminum
2½" NPT	2½" BSP	<b>ASFI25T25B</b>
3" NPT	3" BSP	<b>ASFI30T30B</b>
2½" NPT	2½" NPT	<b>ASFI25T25T</b>
3" NPT	3" NPT	<b>ASFI30T30T</b>

## Dust Plug for Couplers



composite plug

- Composite (Polyeten PE-HD 300) plug provides good protection against corrosion and withstands hot and cold environments.

### composite dust plug for couplers

Size	Body Size	Polyeten PE-HD 300
2½"	ISO 45	<b>DADP250</b>

## Dry Aviation Couplings Adapter - Tank Unit

Dry aviation couplings are designed for use in aviation refueling systems. Manufactured to accept the international standard 2½" point bayonet, hose end refueling nozzles according to: ISO45 / MS24484 / STANAG 3105 / British Aerospace Spec. 2C14. **They are not configured for under-wing refueling.**

- gunmetal coupling ring minimizes the risk of seizure
- PTFE bearings between the piston shaft and the piston guide eliminate the risk of seizure
- conical valve seat eliminates the risk of "piston blow out" when extreme pressure is used

### Technical Information:

- body: high strength aluminum
- bayonet flange and inner parts: stainless steel, aluminum
- all wetted parts are aluminum and stainless steel
- coupling ring: gunmetal
- **150 PSI** working pressure at ambient temperature (70°F)

### aviation adapters x female NPT with Viton® seals

Female NPT	Body Size	Aluminum
2½"	ISO 45	<b>DAA250AL</b>
3"	ISO 45	<b>DAA300AL</b>

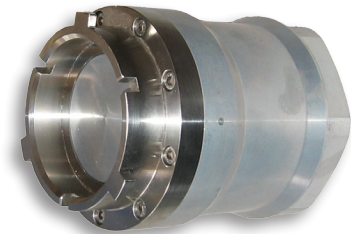

adapter x female NPT - DAA250AL

### aviation adapters x 150# ASA flange with Viton® seals

Female BSP	Body Size	Aluminum
2½"	ISO 45	<b>DAA250ALFL</b>
3"	ISO 45	<b>DAA300ALFL</b>

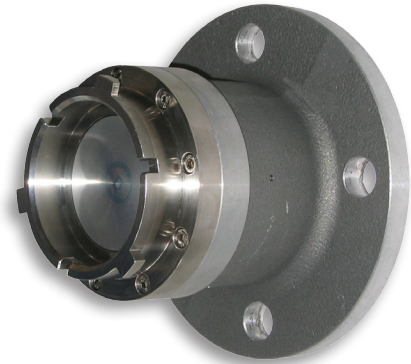

adapter x 150# ASA flange - DAA250ALFL

## Dust Cap for Adapter

- Composite (Polyeten PE-HD 300) cap provides good protection against corrosion and withstands hot and cold environments.

### composite dust caps for adapters

Size	Body Size	Polyeten PE-HD 300
2½"	ISO 45	<b>DADC250</b>

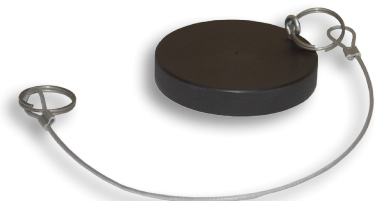

composite cap

# Dry Gas Couplings

## Hose Unit

Dry gas couplings are designed for safe loading and discharge of bulk delivery trucks and rail cars. They are quick and easy to connect and can be connected to a tank unit with pressures up to **225 PSI**. If the pressure is higher you can equip the couplings with a pressure relief valve. The easy to connect pressure relief valve dissipates trapped fluid pressure into the hose coupler without spillage. The primary application of dry gas couplings is in the handling of LPG - Propane and Butane.

### Technical Information:

- stainless steel and brass / gunmetal  
*(produced to U.S. government bronze specification G)*
- Viton® seals
- female NPT and ASA flanges
- **360 PSI** working pressure at ambient temperature (70°F)

- safe handling of LPG
- easy to use and saves time
- reliable and easy to maintain
- can be coupled against higher pressure
- minimizes the risk of cold burns
- minimizes spillage and product loss
- minimizes health risks
- keeps the environment free of hazardous vapors and liquids

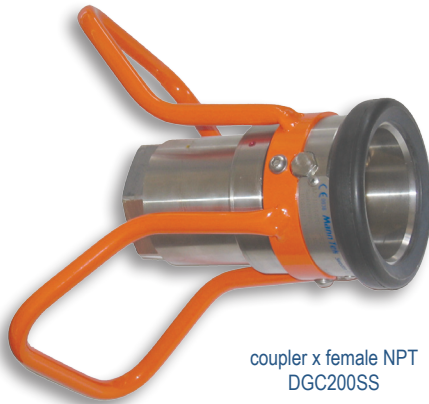

### dry gas couplers x female NPT with Viton® seals

Female NPT	Body Size	Stainless Steel
1"	56 mm	<b>DGC100SS</b>
2"	71 mm	<b>DGC200SS</b>
3"	119 mm	<b>DGC300SS</b>

## Dust Plugs for Couplers

- Composite (Polyeten PE-HD 300) plugs provide good protection against corrosion and withstand hot and cold environments



### composite dust plugs for couplers

Size	Body Size	Polyeten PE-HD 300
1"	56 mm	<b>DGDP100</b>
2"	71 mm	<b>DGDP200</b>
3"	119 mm	<b>DGDP300</b>



## Dry Gas Couplings Tank Unit

Dry gas couplings are designed for safe loading and discharge of bulk delivery trucks and rail cars. They are quick and easy to connect and can be connected to a tank unit with pressures up to **225 PSI**. If the pressure is higher you can equip the couplings with a pressure relief valve. The easy to connect pressure relief valve dissipates trapped fluid pressure into the hose coupler without spillage. The primary application of dry gas couplings is in the handling of LPG - Propane and Butane.

- safe handling of LPG
- easy to use and saves time
- reliable and easy to maintain
- can be coupled to a tank unit with pressures up to **225 PSI**
- minimizes the risk of cold burns
- minimizes spillage and product loss
- minimizes health risks
- keeps the environment free of hazardous vapors and liquids

### Technical Information:

- stainless steel and brass / gunmetal  
*(produced to U.S. government bronze specification G)*
- Viton® seals
- female NPT, female ACME thread and ASA flanges
- **360 PSI** working pressure

### dry gas adapters x female NPT with Viton® seals

Female NPT	Body Size	Stainless Steel
1"	56 mm	<b>DGA100SS</b>
2"	71 mm	<b>DGA200SS</b>
3"	119 mm	<b>DGA300SS</b>

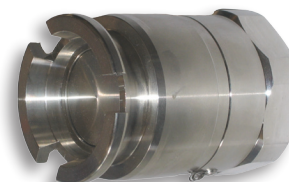

adapter x female NPT - DGA200SS

### dry gas adapters x female ACME thread with Viton® seals

Female ACME	Body Size	Stainless Steel
1¼"	56 mm	<b>DGA100SS175</b>
3¼"	71 mm	<b>DGA200SS325</b>

### dry gas adapters x 150# ASA flange with Viton® seals

150# ASA	Body Size	Stainless Steel
1"	56 mm	<b>DGA100SSFL</b>
2"	71 mm	<b>DGA200SSFL</b>
3"	119 mm	<b>DGA300SSFL</b>

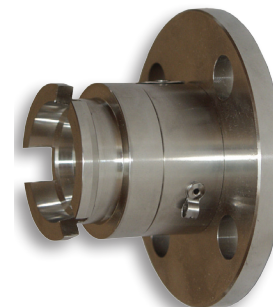

adapter x 150# ASA flange - DGA200SSFL

## Dust Caps

### dust caps for adapters

Size	Body Size	Polyeten PE-HD 300	Rubber
1"	56 mm	<b>DGDC100</b>	---
2"	71 mm	---	<b>DGDC200</b>
3"	119 mm	---	<b>DGDC300</b>



rubber cap

# Dry Disconnect Couplings

Flow Rate

Media: Water Temp: 60° F

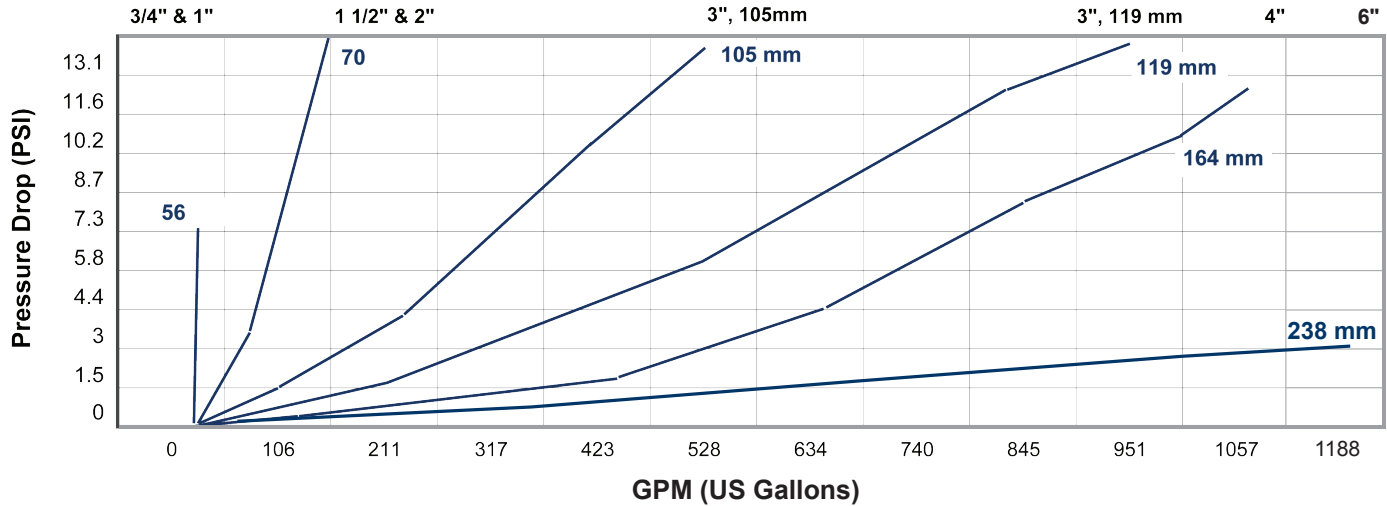

## Spillage on Disconnection

The test was made by coupling and uncoupling 10 times under pressures between one (1) and ten (10) bars. The result we got is a total spillage over 10 coupling cycles and an average spillage on each coupling cycle. The test was carried out with water under ambient temperature.

Size	Socket diameter	Total spill 10 cycles	Average spill 1 cycle
1" – DN 25	56 mm	1 ml	0,1 ml
2" – DN 50	70 mm	3 ml	0,3 ml
2½" – DN 65	105 mm	8 ml	0,8 ml
3" – DN 80	119 mm	10 ml	1,0 ml
4" – DN 100	164 mm	35 ml	3,5 ml

## Options for Hose and Tank Units



### Electronic Sensors

**Electronic Sensors** detect the position of the driving plate inside of the hose unit.

No modification on the tank is required. This makes it possible to identify if the hose unit is connected to a tank unit and if they are in an open position.



## Dry Disconnect Couplings Options for Hose and Tank Units

### Locking Devices

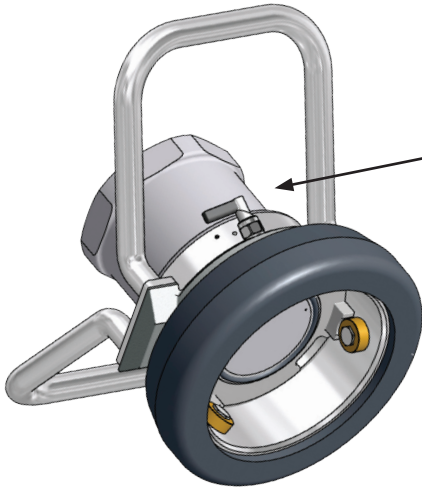

4" Hose unit with locking device

**Locking Devices** eliminate the unintentional disconnection when subjected to vibration from transfer pumps



2" Hose unit with locking device

### Selectivity Options

**Selectivity** versions of Hose and Tank units are available to prevent the accidental mixing of media.

The Tank units are furnished with slots and the Hose unit with pins that interlock upon connection.

The number of selectivity options are possible depending on coupling size.

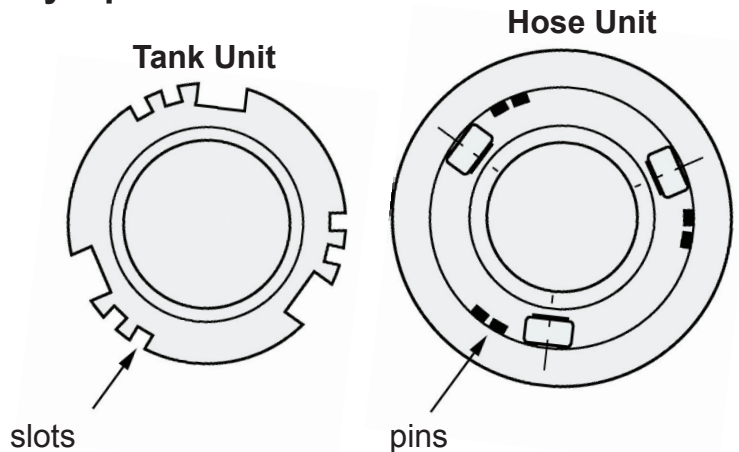

### Handle Options

Optional handles are available for 1"-4" Hose couplers. *2" Hose unit shown.*

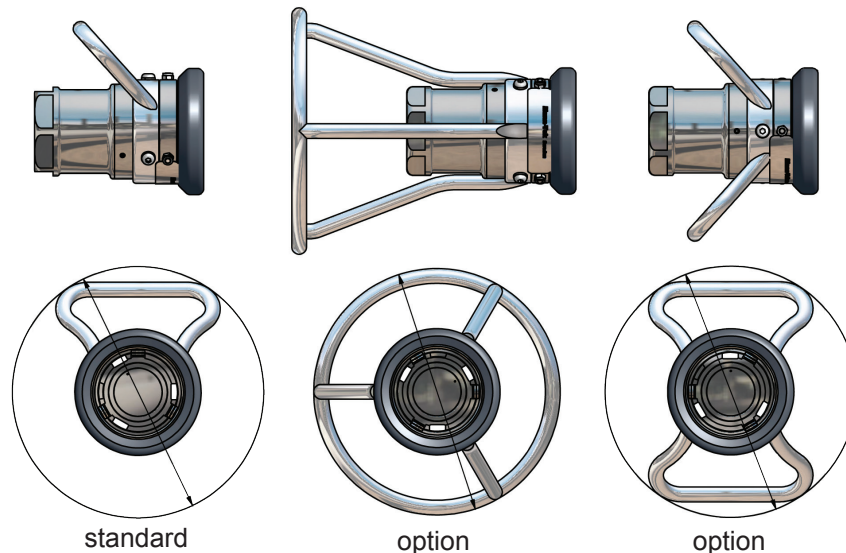

standard

option

option

# Dry Break Cam & Groove Style Dry Disconnect Couplings

## Couplers

- dry disconnect coupler has automatic closing poppet assembly
- heavy duty stainless steel crank and link provide long service life
- stainless steel handle allows product exposure to corrosive chemicals or washdown service
- strong handle attachment prevents bending of crank assembly
- **fully interchangeable with Kamvalok (OPW trademark) style fittings**
- aluminum fittings have stainless steel<sup>1</sup> internals
- for pressure ratings at other temperatures, contact the factory
- Boss-Lock cam arms standard on all fittings, provide high security from accidental opening due to vibration or snagging
- large paddle type cam arms standard on 3" fittings, allow for an easy grip
- for information on repair kits visit us on-line at [www.szalaikft.hu](http://www.szalaikft.hu)

Must be used with a DBA style adapter for coupler to operate.

Adapter sold separately.

(see next page)

**SAFETY**  
**ALERT**

- <sup>1</sup> stainless steel corrosion resistance is comparable to 304 stainless steel
- <sup>2</sup> Kalrez<sup>®</sup> gasket, main seal O-ring and handle O-ring. PTFE seals on cylinder assembly, stuffing box, and seal under poppet screw.

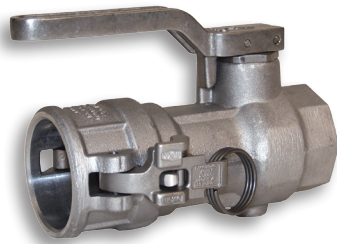

coupler x female NPT - DBC71-200



coupler x female NPT - DBC61-300

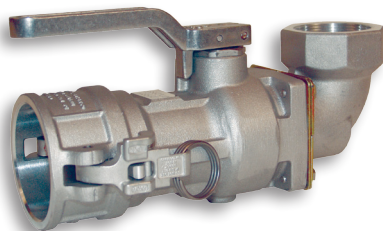

coupler x 90° swivel female NPT - DSB61-200



locking kit - DBCL200



dust plug - G200-DP-AL

### coupler x female NPT

Female NPT	Coupler Size	Seal Material	Aluminum		Stainless Steel <sup>1</sup>	
			New #	OPW #	New #	OPW #
1½"	2"	Buna	<b>DBC61-150</b>	1711D-AL15/1761	<b>DBC71-150</b>	1771D-SS15
2"	2½"		<b>DBC61-200</b>	1711D-AL20/1761	<b>DBC71-200</b>	1771D-SS20
3"	4"		<b>DBC61-300</b>	1711D-AL30	<b>DBC71-300</b>	1771D-SS30
1½"	2"	Viton <sup>®</sup>	<b>DBC62-150</b>	1712D-AL15/1762	<b>DBC72-150</b>	1772D-SS15
2"	2½"		<b>DBC62-200</b>	1712D-AL20/1762	<b>DBC72-200</b>	1772D-SS20
3"	4"		<b>DBC62-300</b>	1712D-AL30	<b>DBC72-300</b>	1772D-SS30
1½"	2"	PTFE Encap. Silicone and Kalrez <sup>®</sup>	<b>DBC63-150</b>	1763D-AL15	<b>DBC73-150</b>	1773D-SS15
2"	2½"		<b>DBC63-200</b>	1763D-AL20	<b>DBC73-200</b>	1773D-SS20
3"	4"		<b>DBC63-300</b>	1763D-AL30	<b>DBC73-300</b>	1773D-SS30
1½"	2"	EPT	<b>DBC64-150</b>	1764D-AL15	<b>DBC74-150</b>	1774D-SS15
2"	2½"		<b>DBC64-200</b>	1764D-AL20	<b>DBC74-200</b>	1774D-SS20
3"	4"		<b>DBC64-300</b>	1764D-AL30	<b>DBC74-300</b>	<b>1774D-SS30</b>
1½"	2"	Kalrez <sup>®</sup> and PTFE	---	---	<b>DBC76-150</b>	1776D-SS15
2"	2½"		<b>DBC66-200</b>	1766D-AL20	<b>DBC76-200</b>	1776D-SS20
3"	4"		---	---	<b>DBC76-300</b>	1776D-SS30
1½"	2"	PTFE Encap. Viton <sup>®</sup> and Kalrez <sup>®</sup>	<b>DBC67-150</b>	1777D-AL15	<b>DBC77-150</b>	1777D-SS15
2"	2½"		<b>DBC67-200</b>	1777D-AL20	<b>DBC77-200</b>	1777D-SS20
3"	4"		<b>DBC67-300</b>	1777D-AL30	<b>DBC77-300</b>	1777D-SS30
3"	4"	Viton <sup>®</sup> B	<b>DBC69-300</b>	1769D-AL30	<b>DBC79-300</b>	1779D-SS30

### greaseless coupler x female NPT

Female NPT	Coupler Size	Seal Material	Aluminum	Stainless Steel
1½"	2"	PTFE Encap. Viton <sup>®</sup> and Kalrez <sup>®</sup>	<b>DBC67-150-GL</b>	<b>DBC77-150-GL</b>
2"	2½"		<b>DBC67-200-GL</b>	<b>DBC77-200-GL</b>
3"	4"		<b>DBC67-300-GL</b>	<b>DBC77-300-GL</b>

### coupler x 90° swivel female NPT

Female NPT	Coupler Size	Seal Material	Aluminum	
			Dixon #	OPW #
2"	2½"	Buna	<b>DBS61-200</b>	1711ES-0200
2"	2½"	Viton <sup>®</sup>	<b>DBS62-200</b>	1712ES-0200
2"	2½"	PTFE Encap. Silicone and Kalrez <sup>®</sup>	<b>DBS63-200</b>	---

### Locking Kit for Couplers

- prevents unintentional opening of poppet assembly

Description	Aluminum
for use with 1½" and 2" cam and groove couplers	<b>DBCL-200</b>
for use with 3" cam and groove couplers	<b>DBCL-300</b>

### Dust Plugs for Couplers

Size	Aluminum	Stainless Steel
2"	<b>G200-DP-AL</b>	<b>G200-DP-SS</b>
2½"	<b>G250-DP-AL</b>	<b>G250-DP-SS</b>
4"	<b>G400-DP-AL</b>	<b>G400-DP-SS</b>

## Dry Break Cam & Groove Style Dry Disconnect Couplings Adapters

Compatible with most cam and groove style dry disconnects, the Bayco dry disconnect helps prevent spillage from normal or accidental disconnects. A spring loaded sealing device is designed to "snap" closed should the valve become disconnected with the poppet open, significantly limiting liquid loss.

- two-piece design for easy rebuilding of adapters
- **fully interchangeable with Kamvalok (OPW trademark) style fittings**
- aluminum fittings have aluminum nose piece and brass piston
- for pressure ratings at other temperatures, contact the factory
- for information on repair kits visit us on-line at [www.szalai.kft.hu](http://www.szalai.kft.hu)

<sup>1</sup> stainless steel corrosion resistance is comparable to 304 stainless steel

### adapter x female NPT

Female NPT	Adapter Size	Seal Material	Aluminum		Stainless Steel <sup>1</sup>	
			New #	OPW #	New #	OPW #
1½"	2"	Buna	<b>DBA11-150</b>	1611AN-AL15	<b>DBA71-150</b>	1671AN-SS15
2"	2½"		<b>DBA11-200</b>	1611AN-AL20	<b>DBA71-200</b>	1671AN-SS20
3"	4"		<b>DBA11-300</b>	1611AN-AL30	<b>DBA71-300</b>	1671AN-SS30
1½"	2"	Viton®	<b>DBA12-150</b>	1612AN-AL15	<b>DBA72-150</b>	1672AN-SS15
2"	2½"		<b>DBA12-200</b>	1612AN-AL20	<b>DBA72-200</b>	1672AN-SS20
3"	4"		<b>DBA12-300</b>	1612AN-AL30	<b>DBA72-300</b>	1672AN-SS30
1½"	2"	PTFE Encap. Silicone	<b>DBA63-150</b>	1613AN-AL15	<b>DBA73-150</b>	1673AN-SS15
2"	2½"		<b>DBA63-200</b>	1613AN-AL20	<b>DBA73-200</b>	1673AN-SS20
3"	4"		<b>DBA63-300</b>	1613AN-AL30	<b>DBA73-300</b>	1673AN-SS30
1½"	2"	EPT	<b>DBA64-150</b>	1614AN-AL15	<b>DBA74-150</b>	1674AN-SS15
2"	2½"		<b>DBA64-200</b>	1614AN-AL20	<b>DBA74-200</b>	1674AN-SS20
3"	4"		<b>DBA64-300</b>	1614AN-AL30	<b>DBA74-300</b>	1674AN-SS30
1½"	2"	Kalrez®	<b>DBA66-150</b>	1616AN-AL15	<b>DBA76-150</b>	1676AN-SS15
2"	2½"		<b>DBA66-200</b>	1616AN-AL20	<b>DBA76-200</b>	1676AN-SS20
3"	4"		<b>DBA66-300</b>	1616AN-AL30	<b>DBA76-300</b>	1676AN-SS30
1½"	2"	PTFE	---	---	<b>DBA77-150</b>	1677AN-SS15
2"	2½"	Encap.	---	---	<b>DBA77-200</b>	1677AN-SS20
3"	4"	Viton®	---	---	<b>DBA77-300</b>	1677AN-SS30
3"	4"	Viton® B	<b>DBA69-300</b>	1619AN-AL30	---	---

### jump size adapter x female NPT

Female NPT	Adapter Size	Seal Material	Aluminum	
			New #	OPW #
2"	2"	Buna	<b>DBA11-1520</b>	---
2"	2"	Viton®	<b>DBA12-1520</b>	---

### adapter x 150# ASA flange

Flange Size	Adapter Size	Seal Material	Stainless Steel <sup>1</sup>	
			New #	OPW #
2"	2"	Viton®	<b>DBAF72-1520</b>	1672ANF-SS15
2"	2½"		<b>DBAF72-200</b>	1672ANF-SS20
3"	4"		<b>DBAF72-300</b>	1672ANF-SS30
2"	2"	PTFE Encap. Silicone	<b>DBAF73-1520</b>	1673ANF-SS15
2"	2½"		<b>DBAF73-200</b>	1673ANF-SS20
3"	4"		<b>DBAF73-300</b>	1673ANF-SS30
2"	2"	EPT	<b>DBAF74-1520</b>	1674ANF-SS15
2"	2½"		<b>DBAF74-200</b>	1674ANF-SS20
3"	4"		<b>DBAF74-300</b>	1674ANF-SS30
2"	2"	Kalrez®	<b>DBAF76-1520</b>	1676ANF-SS15
2"	2½"		<b>DBAF76-200</b>	1676ANF-SS20
3"	4"		<b>DBAF76-300</b>	1676ANF-SS30

### vapor adapter x female NPSM

Female NPSM	Adapter Size	Seal Material	Stainless Steel <sup>1</sup>	
			New #	OPW #
3"	2"	PTFE	<b>DBAV73-2030</b>	2173AVN



adapter x female NPT - DBA71-200



adapter x female NPT - DBA11-300

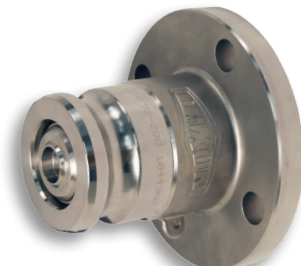

adapter x flange - DBAF71-200



vapor adapter x female NPSM - DBAV73-2030



dust cap 200-DC-AL

### Dust Caps for Adapters

Size	Aluminum	Stainless Steel
2"	<b>G200-DC-AL</b>	<b>G200-DC-SS</b>
2½"	<b>G250-DC-AL</b>	<b>G250-DC-SS</b>
4"	<b>G400-DC-AL</b>	<b>G400-DC-SS</b>

# Dry Break Cam & Groove Style Dry Disconnect Couplings

Flow Chart

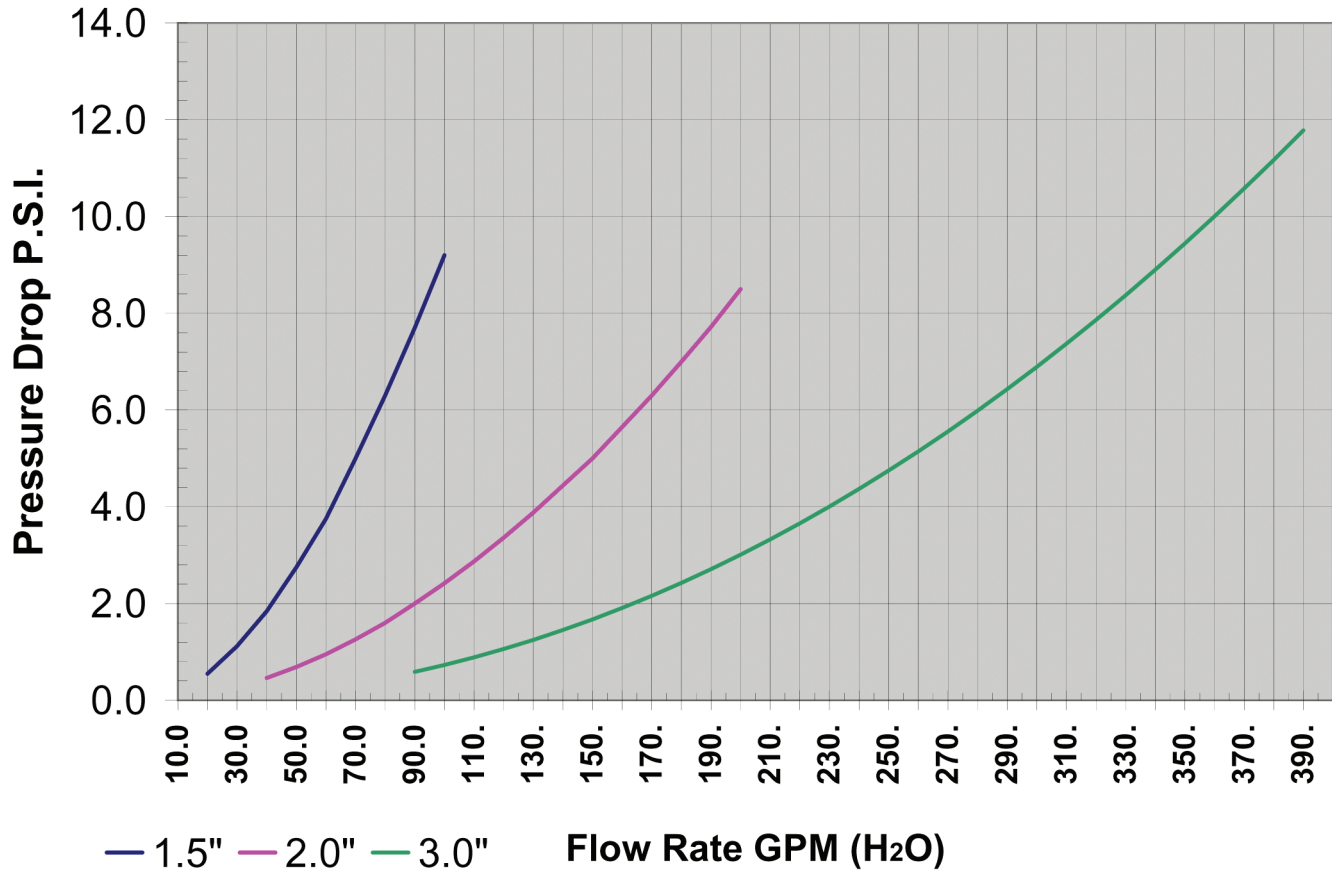

## Dry Break Adapters DBA Series with Female NPT

example part # *DBA72-200*

component material  
seal material  
thread size

Dry Break Adapter with all stainless components, Viton® seals and 2" NPT thread

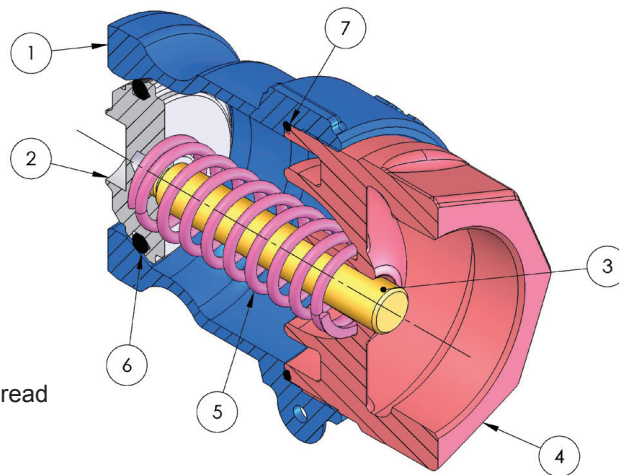

	Item	Description
Components	1	adapter end
	2	poppet
	3	stem
	4	pipe end
	5	spring
Seals	6	poppet O-ring
	7	body O-ring

All metallic parts not listed are stainless steel.  
All non-metallic parts not listed are PTFE.

# Dry Break Cam & Groove Style Dry Disconnect Couplings

## Dry Break Couplers DBC series with Female NPT

example part # *DBC72-200*

component material  
seal material  
thread size

Dry Break Coupler with all stainless components, Viton® seals and 2" NPT thread

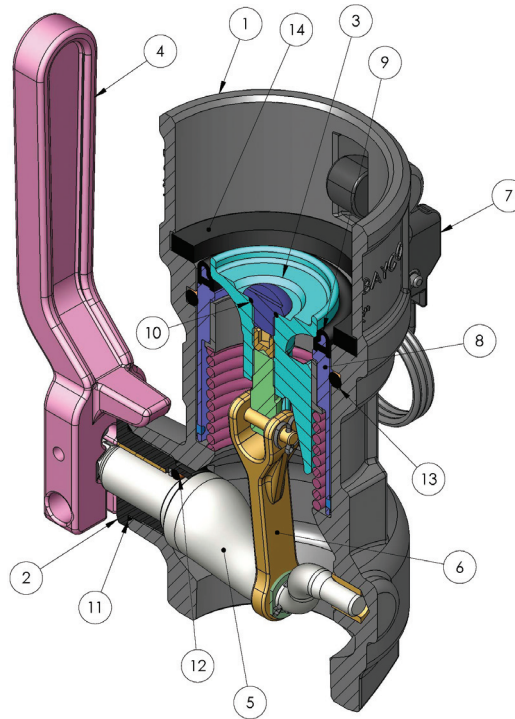

	Item	Description
Components	1	body
	2	stuffing box
	3	poppet
	4	handle
	5	crank
	6	link
	7	cam arm
	8	cylinder
Seals	9	nose seal
	10	screw O-ring
	11	stuffing box seal
	12	crank seal
	13	cylinder seal
	14	gasket

All metallic parts not listed are stainless steel.  
All non-metallic parts not listed are PTFE.

## Dry Break Couplers DBC series with Female NPT

example part # *DBC72-300*

component material  
seal material  
thread size

Dry Break Coupler with all stainless components, Viton® seals and 3" NPT thread

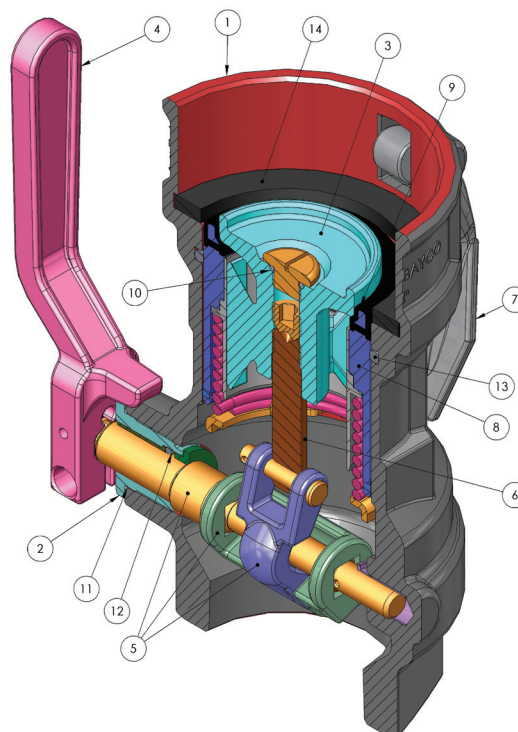

	Item	Description
Components	1	body
	2	stuffing box
	3	poppet
	4	handle
	5	crank
	6	link
	7	cam arm
	8	cylinder
Seals	9	nose seal
	10	screw O-ring
	11	stuffing box seal
	12	crank seal
	13	cylinder seal
	14	gasket

All metallic parts not listed are stainless steel.  
All non-metallic parts not listed are PTFE.

# Bayonet Style Dry Disconnect Couplings



coupler x straight female NPT - BC62-200

Bayco brand BA and BS series bayonet dry disconnect fittings are designed for use in the fuel and lube oil service industry. These fittings are compatible with Emco Wheaton™ Dry Break™, commonly found in these services. The maximum pressure rating for fittings is **85 PSI** at 70°F, for pressure ratings at other temperatures contact Dixon..

- for information on repair kits visit us on-line at [www.dixonvalve.com](http://www.dixonvalve.com)



coupler x straight swivel female NPT - BSS62-300

### bayonet style coupler x straight female NPT

Size	Seal Material	Anodized Aluminum	
		Dixon #	Emco Wheaton™ #
2"	Buna	<b>BC61-200</b>	J72C-ABN0-B
2"	Viton®	<b>BC62-200</b>	J72C-AVN0-B



coupler x 90° swivel female NPT - BS62-200

### bayonet style coupler x straight swivel female NPT

Size	Seal Material	Anodized Aluminum	
		Dixon #	Emco Wheaton™ #
2"	Buna	<b>BSS61-200</b>	J72C-ABN1-B
2"	Viton®	<b>BSS62-200</b>	J72C-AVN1-B
3"	Buna	<b>BSS61-300</b>	J73C-ABN1-B
3"	Viton®	<b>BSS62-300</b>	J73C-AVN1-B



coupler x 90° swivel female NPT - BS62-300

### bayonet style coupler x 90° swivel female NPT

Size	Seal Material	Anodized Aluminum	
		Dixon #	Emco Wheaton™ #
2"	Buna	<b>BS61-200</b>	J72C-ABN2-B
2"	Viton®	<b>BS62-200</b>	J72C-AVN2-B
3"	Buna	<b>BS61-300</b>	J73C-ABN2-B
3"	Viton®	<b>BS62-300</b>	J73C-AVN2-B



dust plug BCP-200

### Dust Plugs for Couplers

Size	Part #
2"	<b>BCP-200</b>
3"	<b>BCP-300</b>

Rubber dust plugs come with stainless steel chains.



## Bayonet Style Dry Disconnect Couplings Adapters

Bayco brand BA and BS series bayonet dry disconnect fittings are designed for use in the fuel and lube oil service industry. These fittings are compatible with Emco Wheaton™ Dry Break™, commonly found in these services. The maximum pressure rating for fittings is **85 PSI** at 70°F, for pressure ratings at other temperatures contact Dixon..

- for information on repair kits visit us on-line at [www.dixonvalve.com](http://www.dixonvalve.com)

### bayonet style adapter x female NPT

Size	Seal Material	Stainless Steel	
		Dixon #	Emco Wheaton™ #
2"	Buna	<b>BA31-200</b>	J72A-BBN0-B / J72A-ABN0-B
2"	Viton®	<b>BA32-200</b>	J72A-BVN0-B / J72A-AVN0-B



adapter x female NPT - BA32-200

### bayonet style adapter x female NPT

Size	Seal Material	Brass	
		Dixon #	Emco Wheaton™ #
3"	Buna	<b>BA31-300</b>	J73A-BBN0-B
3"	Viton®	<b>BA32-300</b>	J73A-BVN0-B

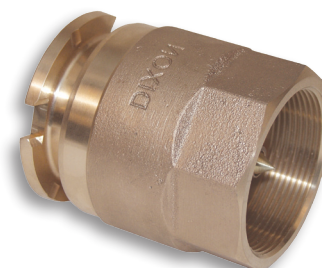

adapter x female NPT - BA31-300

### bayonet style adapter x female NPT

Size	Seal Material	Aluminum	
		Dixon #	Emco Wheaton™ #
3"	Buna	<b>BA61-300</b>	J73A-ABN0-B
3"	Viton®	<b>BA62-300</b>	J73A-AVN0-B



adapter x female NPT - BA62-300

## Dust Caps for Adapters

Size	Body Size	Polyeten PE-HD 300
2"	70mm	<b>DDDC150</b>
3"	105mm	<b>DDDC300105</b>



composite dust cap DDDC300

Size	Body Size	Rubber
2"	71mm	<b>BAC-200</b>
3"	119mm	<b>BAC-300</b>



rubber dust cap BAC-300

Rubber dust plugs come with stainless steel chains.

# Industrial Safety Break-Away Couplings - Breaking Bolt Series

## Advantages



Industrial break-away coupling can be utilized for most industrial product transfer installations.

The industrial SBCouplings are specifically designed to be able to activate with a tensile force being applied at an angle to the plane of the coupling housing, up to 90 degrees.

---

## Key Features

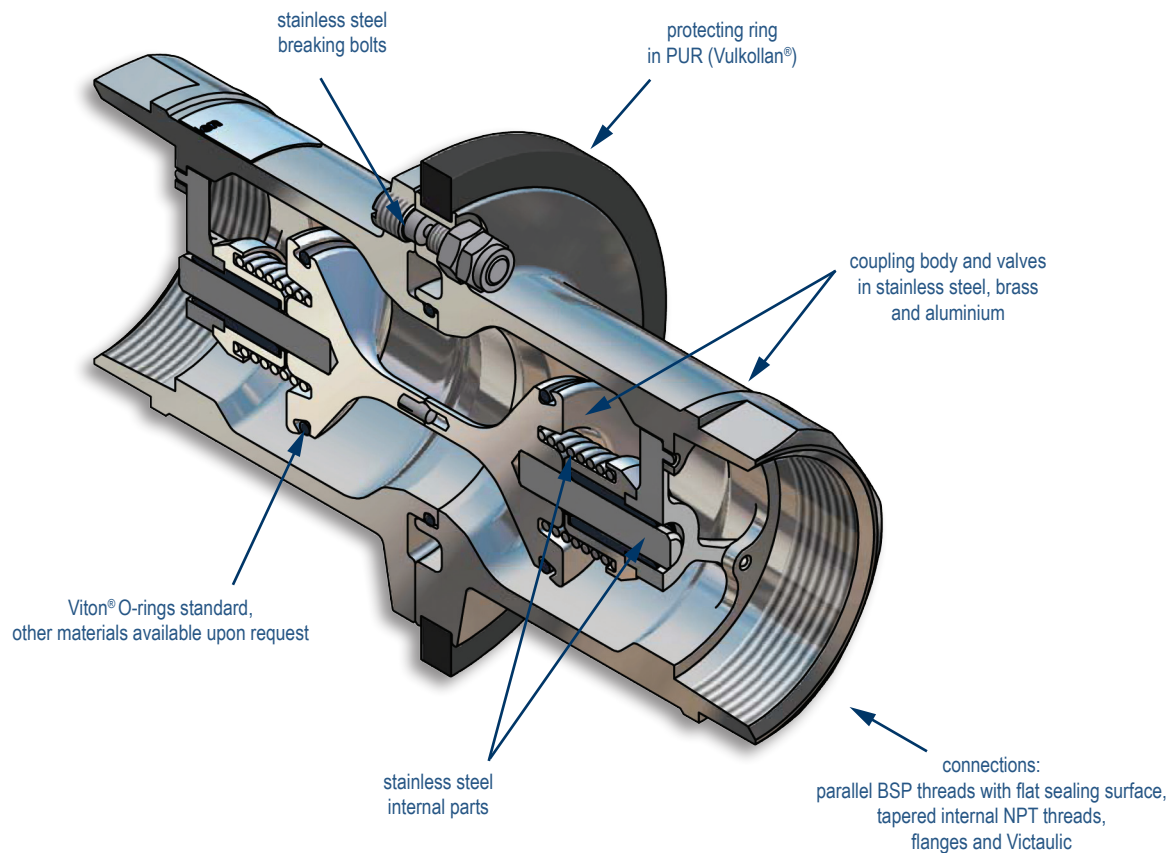

## Safety Break-Away Couplings Industrial Version

The breaking bolt industrial breakaway coupling is designed to minimize spillage and damage associated with drive away and pull away incidents.

- **designed to be installed between a fixed point (pipe, pump, manifold) and a hose**
- coupling automatically senses an excessive load, closes the valves and disconnects (*see page 24*)
- simple dependable mechanism
- high flow rate / low pressure drop
- female NPT is standard, optional ASA/ DIN flanges or male NPT are available
- Viton® is standard seal
- Working pressure: stainless steel **360 PSI** and aluminum **230 PSI** at ambient temperature (70°F)
- for information on repair kits visit us on-line at [www.dixonvalve.com](http://www.dixonvalve.com)

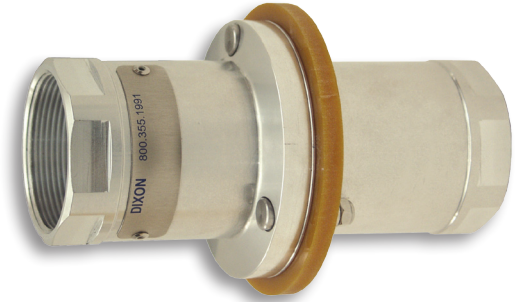

SBC200AL - aluminum

### industrial breaking bolt series

Size	DN	Flow Rate GPM	Width	Length	Weight lbs.		316 Stainless Steel	Aluminum
					SS	AL		
2"	50	<b>200</b>	4.5"	7"	5.7	2.2	<b>SBC200SS</b>	<b>SBC200AL</b>
3"	80	<b>650</b>	6.8"	11"	18.8	7	<b>SBC300SS</b>	<b>SBC300AL</b>
4"	100	<b>800</b>	8.3"	12"	34.1	13	<b>SBC400SS</b>	<b>SBC400AL</b>
5"	125	<b>1100</b>	10.6"	14"	70.4	26.6	<b>SBC500SS</b>	<b>SBC500AL</b>
6"	150	<b>1500</b>	12"	16"	103	37.6	<b>SBC600SS</b>	<b>SBC600AL</b>
6"	150	<b>1500</b>	12.5"	15.1"	110	40	<b>SBC600SSFL **</b>	<b>SBC600ALFL **</b>
8"	200	<b>3700</b>	13.5"	17.7"	157	--	<b>SBC800SSFL **</b>	---

\*\* 150# ASA flange

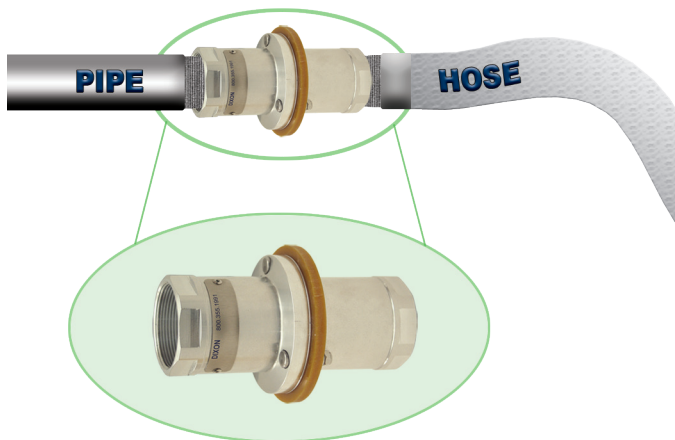

Industrial break-aways are typically installed on a loading arm or manifold and hose assemblies, where at least one side of the coupling is attached to a rigid or fixed point.

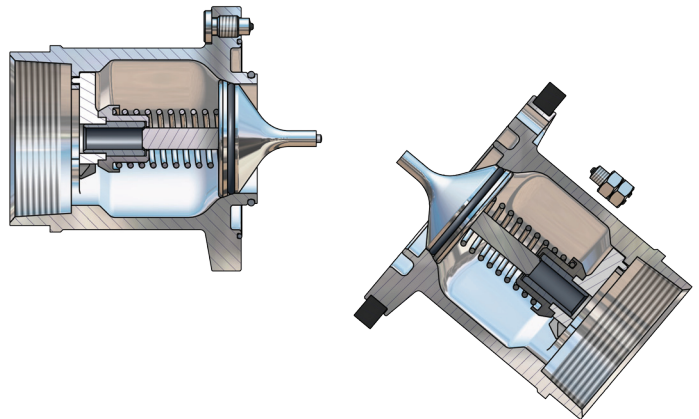

*Release with a tensile force being applied at an angle to the plane of the coupling housing, up to 90 degrees.*

# Marine Safety Break-Away Couplings - Breaking Bolt Series

## Advantages



Marine version of the safety break-away couplings are designed specifically to be installed within a hose string, where the coupling would have a length of hose attached to both sides.

This coupling incorporates the same internal mechanism as our Industrial couplings, but has additional external features that provide increased resistance to torsional and bending moment forces which may be applied to the coupling, preventing premature activation in the unpredictable marine environment.

## Key Features

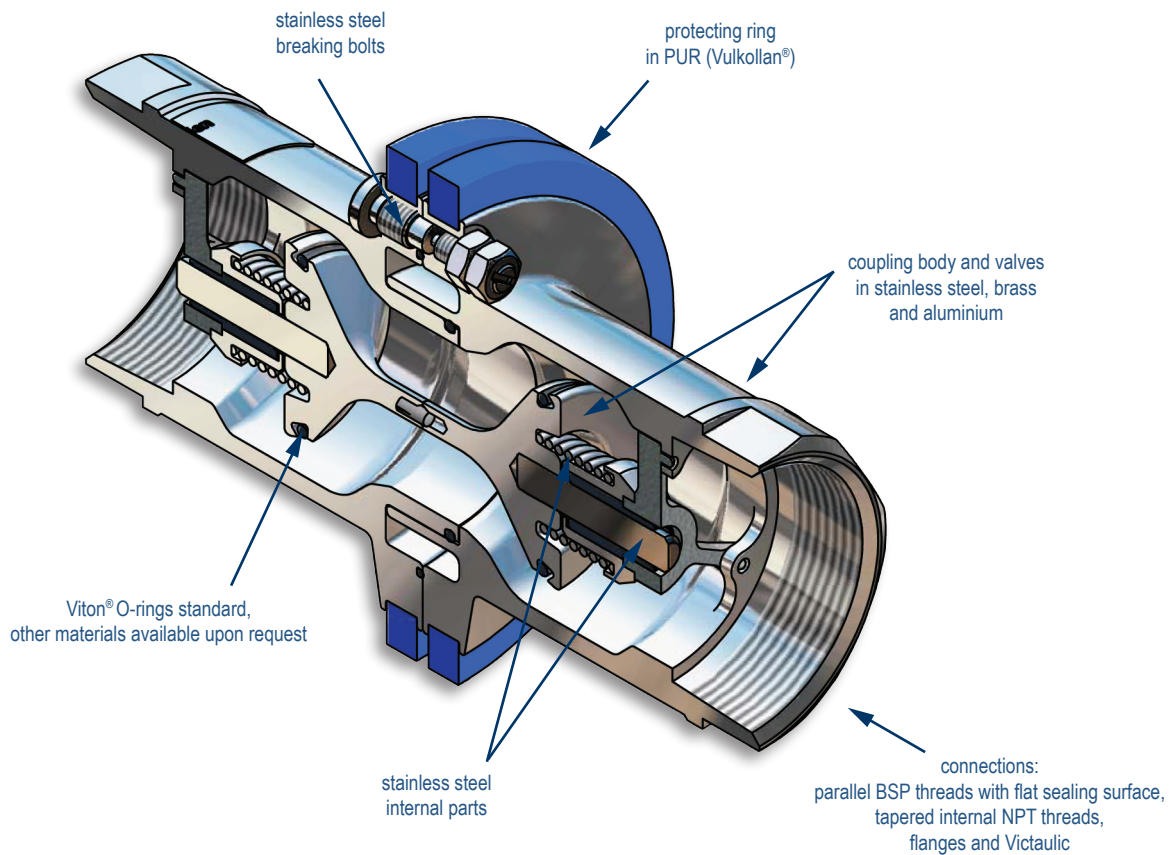

**Safety Break-Away Couplings**  
**Marine Version**

The breaking bolt marine version break-away coupling is designed to minimize spillage and damage associated with pull-away incidents.

- **designed to be installed within a hose string where the coupling will have a length of hose attached to both sides**
- typical applications include: ship-to-offshore platform and ship-to-ship product transfer operations
- coupling automatically senses an excessive load, closes the valves and disconnects (*see page 24*)
- release is executed when force causes bolts to break
- female NPT is standard, optional ASA / DIN flanges or male NPT are available
- Viton® is standard seal
- working pressure of stainless steel is **360 PSI** at ambient temperature (70°F)
- for information on repair kits visit us on-line at [www.dixonvalve.com](http://www.dixonvalve.com)



MSBC300SS - stainless steel

**marine breaking bolt series**

Size	DN	Flow Rate GPM	Width	Length	Weight lbs.	316 Stainless Steel
2"	50	<b>200</b>	4.5"	7"	5.7	<b>MSBC200SS</b>
3"	80	<b>650</b>	6.8"	11"	18.8	<b>MSBC300SS</b>
4"	100	<b>800</b>	8.3"	12"	34.1	<b>MSBC400SS</b>
5"	125	<b>1100</b>	10.6"	14"	70.4	<b>MSBC500SS</b>
6"	150	<b>1500</b>	12"	16"	103	<b>MSBC600SS</b>
6"	150	<b>1500</b>	12.5	15.1	110	<b>MSBC600SSFL</b> **
8"	200	<b>3700</b>	13.5"	17.7"	157	<b>MSBC800SSFL</b> **

\*\* 150# ASA flange

Marine safety break-aways are designed to only release by inline pull and used between two strings of hose.

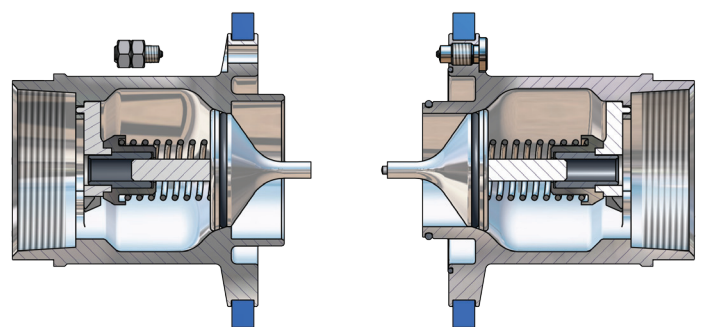
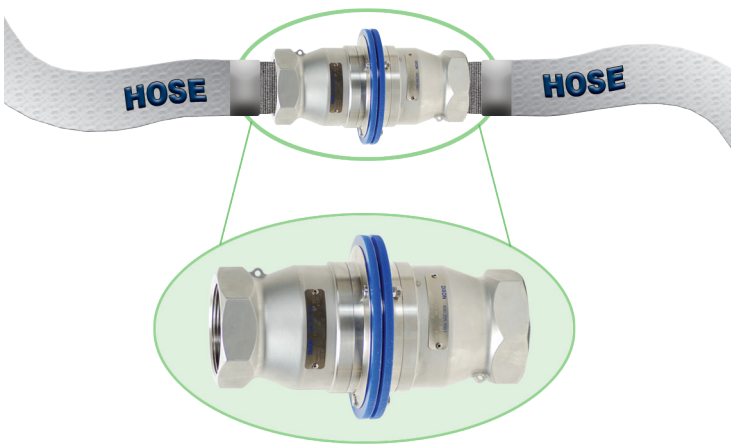

Release by inline pull only.

# Safety Break-Away Couplings - Breaking Bolt Series

## Examples of Connection Combinations

- BSP female thread / BSP female thread
- male thread / male thread
- victaulic / victaulic
- flange / flange
- NPT female thread / NPT female thread
- NPT female thread / NPT male thread (also available with BSP)
- NPT female thread / victaulic
- flange / thread (BSP / NPT female/male or victaulic)

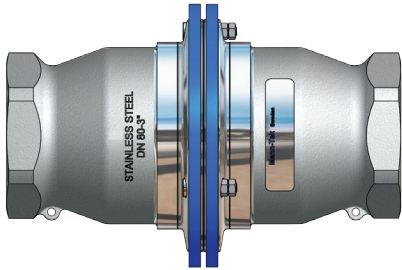

BSP female thread x BSP female thread

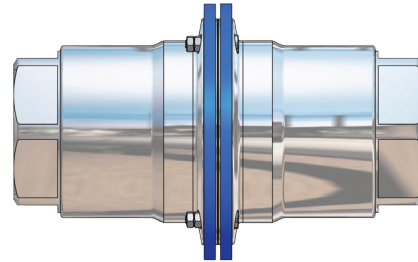

NPT female thread / NPT female thread

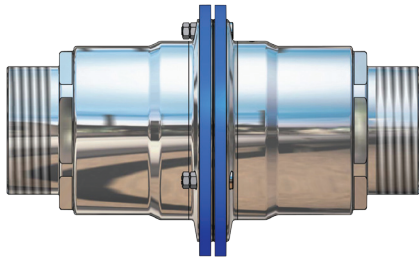

male thread / male thread

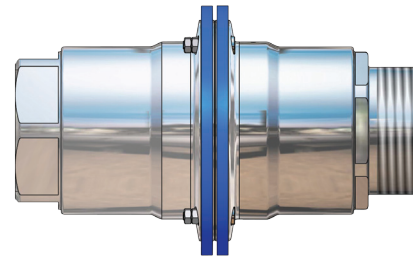

NPT female thread / NPT male thread (also available with BSP)

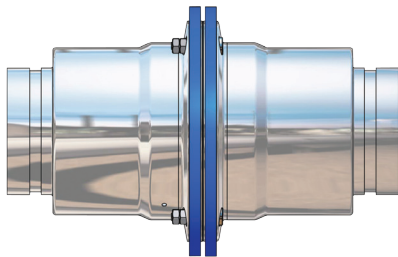

victaulic / victaulic

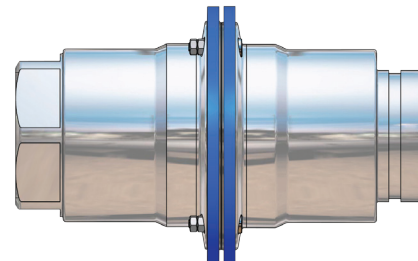

NPT female thread / victaulic

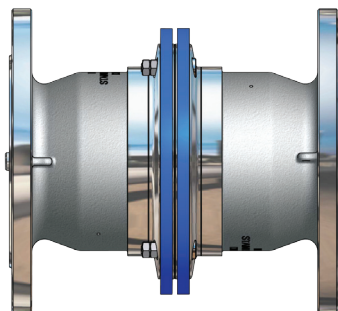

flange / flange

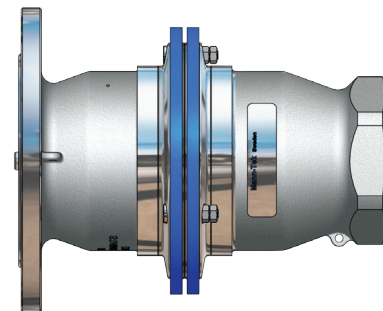

flange / thread (BSP / NPT female / male or victaulic)

## Safety Break-Away Coupling - Options

Where there is a risk of excessive force on the hose due to unexpected movement between the loading and unloading station, combining the dry disconnect coupling or swivel with a safety break away coupling may be a solution.

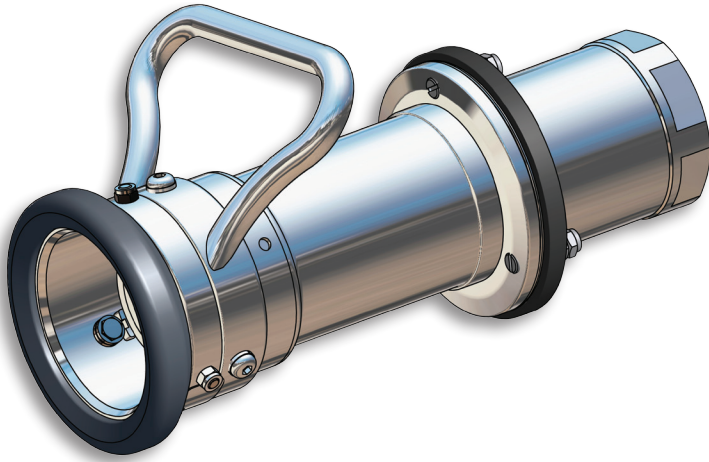

dry disconnect hose unit with break-away integrated



hose swivel with break-away integrated

---

## Non-Closure Design

The non-closure design is an economical alternative which allows the coupling to break away due to pull-away/drive-away incidents thus protecting piping systems and equipment. This design allows spillage of product in these instances due to the lack of valving in the coupling.

Useful in applications where non-hazardous product is being conveyed and where there are no environmental concerns. Available in both Industrial and Marine versions. Consult the factory for more information.

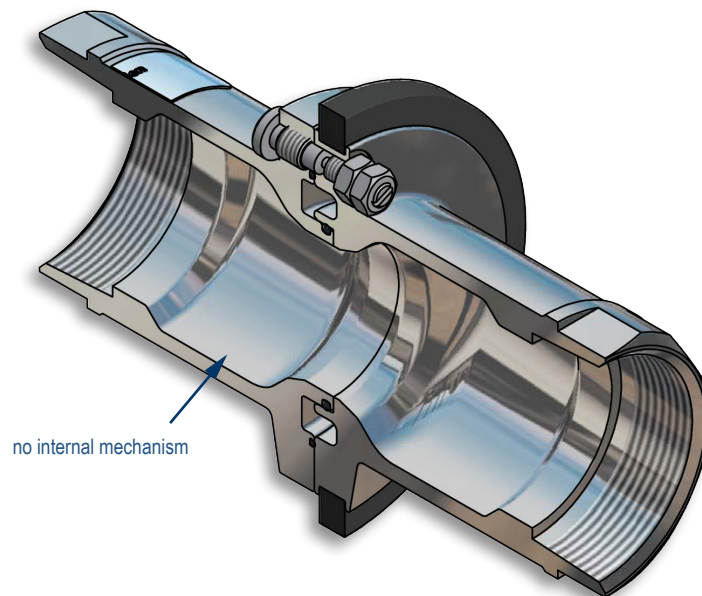

# Safety Break-Away Couplings - Breaking Bolt Series

## How It Works

The SBCouplings, safety break-away couplings, have three external break bolts. In the case of axial tension all of the bolts take up the force corresponding to the break force on the hose with a safety margin.

Non-axial forces concentrate the tension forces more strongly on one bolt, so that the safety break-away coupling reacts in a natural way to the reduction of the hose break forces.

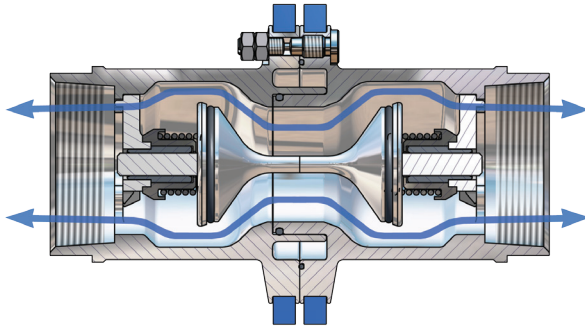

**BEFORE** emergency disconnect

The safety break-away valve consists of two halves, each with a valve that has a o-ring seal.

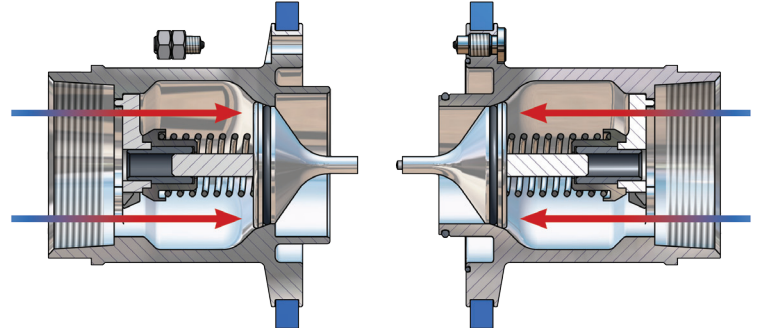

**AFTER** emergency disconnect

When the SBCouplings separate, it allows the valves to close. The two valves close rapidly, minimizing exposure to personnel and the environment.

Break loads for bolts should be based upon information specific to the application such as weight of unsupported hose or pipe and angle of pull associated with the specific application. Contact Dixon regarding specific applications.

### ratings and kits for the standard industrial breaking bolt series

Size	Used On		kN rating	Pounds Force	Kits	
	<i>Stainless Steel</i>	<i>Aluminum</i>			<i>Standard Bolt</i>	<i>Viton® O-ring</i>
2"	SBC200SS	SBC200AL	13 kN	2900	<b>S-N2D-44</b>	<b>O-ND2-01</b>
3"	SBC300SS	SBC300AL	33 kN	7500	<b>S-N4D-44</b>	<b>O-ND4-01</b>
4"	SBC400SS	SBC400AL	52 kN	11,700	<b>S-N5D-44</b>	<b>O-ND5-01</b>
5"	SBC500SS	SBC500AL	81 kN	18,200	<b>S-NVD-44</b>	<b>O-NVD-01</b>
6"	SBC600SS	SBC600AL	92 kN	20,700	<b>S-N6D-44</b>	<b>O-N6D-01</b>
6"	SBC600SSFL	SBC600ALFL	92 kN	20,700	<b>S-N6D-44</b>	<b>O-N6D-01</b>
8"	SBC800SSFL	---	165 kN	37,000	<b>S-N8D-44</b>	<b>O-N8D-01</b>

### ratings and kits for the standard marine breaking bolt series

Size	Used On <i>Stainless Steel</i>	kN rating	Pounds Force	Kits	
				<i>Standard Bolt</i>	<i>Viton® O-ring</i>
2"	MSBC200SS	13 kN	2900	<b>S-N2M-44</b>	<b>O-ND2-01</b>
3"	MSBC300SS	33 kN	7500	<b>S-N4M-44</b>	<b>O-ND4-01</b>
4"	MSBC400SS	52 kN	11,700	<b>S-N5M-44</b>	<b>O-ND5-01</b>
5"	MSBC500SS	81kN	18,200	<b>S-NVM-44</b>	<b>O-NVM-01</b>
6"	MSBC600SS	92 kN	20,700	<b>S-N6M-44</b>	<b>O-N6M-01</b>
6"	MSBC600SSFL	92 kN	20,700	<b>S-N6M-44</b>	<b>O-N6M-01</b>
8"	MSBC800SSFL	165 kN	37,000	<b>S-N8M-44</b>	<b>O-N8M-01</b>



For more information on  
Dry Disconnect Repair Kits,  
Scan with your Smart Phone



## Safety Break-Away Couplings Flow Diagram (Pressure Drop)

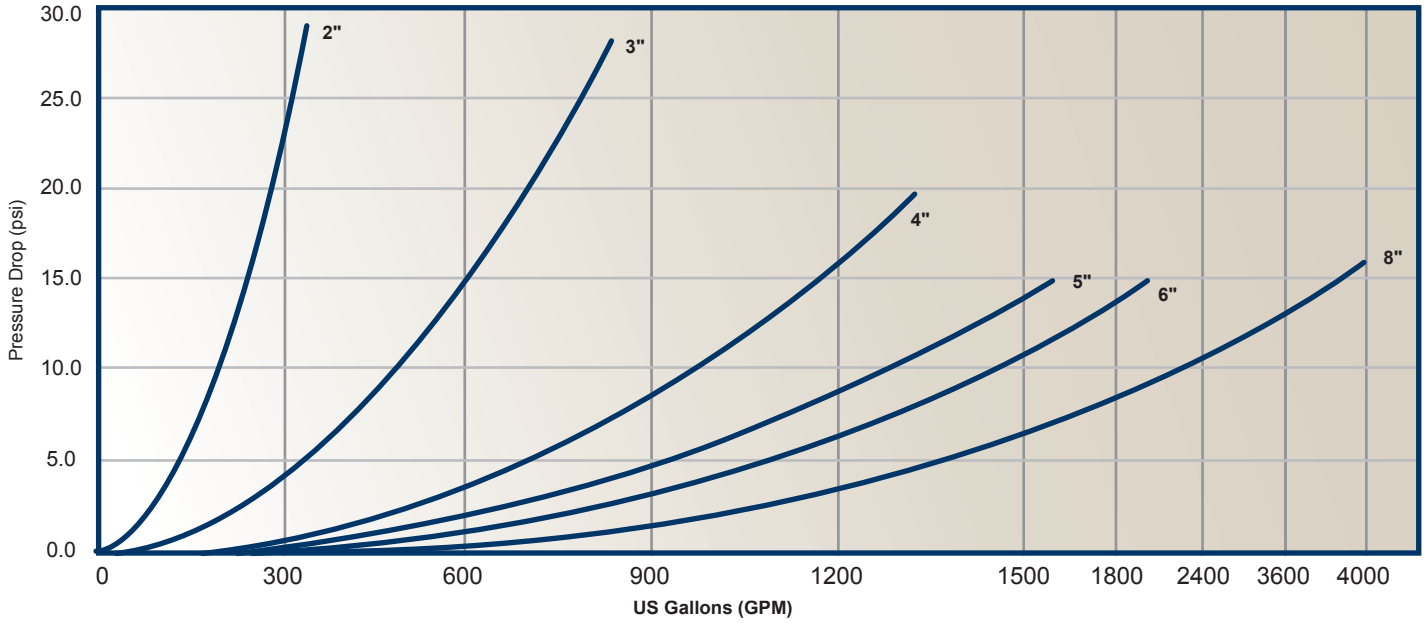

Test Fluid: n-paraffin    Temperature: 70°F    Density: 100 oz/gal    Viscosity: 1,75 cps

### Product Application

products in use at a facility



API couplers

Safety breakaway couplings

## Cam and Groove Actuator Style Fittings couplers

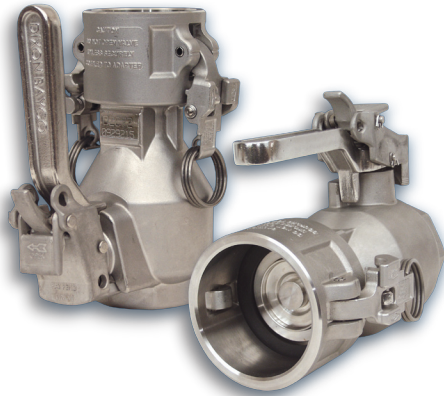

1½" and 2" - stainless steel

The D2C style couplers work with the DBA adapters for applications where automatic closure for the coupler is not desired. This coupler is suited to vapor recovery, suction pump line and applications where it is necessary to easily drain the hose or piping for clean out. It can also be used when product retention in hose or pipe is desired but damage from accidental spill from an open coupler is not a concern.

- 316 stainless steel body
- 304 stainless steel internal components
- EZ Boss-Lock cam arms
- stainless steel locking lever included
- available with Buna, Viton®, Viton-B®, EPDM, PTFE encapsulated Silicone and PTFE encapsulated Viton® seals
- used with poppeted adapter DBA series (*page 13*)

### actuator style couplers

Size	Seal Material	Stainless Steel
1½"	Buna	<b>D2C71-150</b>
2"		<b>D2C71-200</b>
1½"	Viton®	<b>D2C72-150</b>
2"		<b>D2C72-200</b>
1½"	PTFE encapsulated Silicone	<b>D2C73-150</b>
2"		<b>D2C73-200</b>
1½"	EPDM	<b>D2C74-150</b>
2"		<b>D2C74-200</b>
1½"	PTFE encapsulated Viton®	<b>D2C77-150</b>
2"		<b>D2C77-200</b>
1½"	Viton-B®	<b>D2C79-150</b>
2"		<b>D2C79-200</b>

## API Bottom Rack Loading Fittings couplers

Dixon Bayco's API coupler uses a snap on connection where the coupling action is automatic upon contact with the API adapter. The coupler is completely modular so it can be built with various face seal combinations to be compatible with different alternative fuel, performance levels and applications. Two models are available: bonded nose seal and replaceable nose seal.

- 4" TTMA inlet mounting flange
- 5 cam design for easy alignment and tight connection
- ball-end handle for easy, comfortable operation
- no special tools needed for maintenance
- shaft seals can be changed without removing coupler from loading arm
- fully compliant with API RP1004:2003 specifications
- fully interlocked collar can not be opened when connected and can not be disconnected when opened
- one piece bonded nose seal ensures long life and cannot be washed out
- optional replaceable nose seal for quick replacement without removal from loading arm

### Material Specifications:

- body: hard coated anodized AL 356 T6
- shroud: hard coated anodized AL 356 T6 with stainless steel insert
- link, shaft, pin and crank: hardened 17-4PH stainless steel
- cam: CF8M stainless steel
- poppet and bearing: ZA-12
- seal options: Buna, Viton-B®, Viton® GFLT

### Technical Specifications:

- weight: 20 lbs.
- maximum working pressure: **150 PSI**
- peak surge pressure: 350 PSI
- operating temperature:
  - Viton® seals: **-20°F to +400°F**
  - Buna seals: **-20°F to +250°F**
- maximum flow rate: 600 GPM
- pressure drop: 3 to 4 PSI

### API couplers

Seal Material	<i>Bonded Nose Seal #</i>	<i>Replaceable Nose Seal #</i>
Buna	<b>5300</b>	<b>5400</b>
Viton-B®	<b>5300B</b>	<b>5400B</b>
Viton® GFLT	<b>5300G</b>	<b>5400G</b>



bonded nose seal model - 5300

### Chemical Compatibility (Buna seals):

- gasoline
- diesel
- 10% ethanol
- B2 biodiesel blends

### Chemical Compatibility (Viton-B® seals):

- gasoline
- diesel
- jet fuel
- avgas
- 100% ethanol
- 100% methanol
- 100% biodiesel
- any blend of the above fluids



More Information on  
Dry Disconnect Products



Dixon Customer Service



Facebook Page



YouTube Videos

Scan me with your Smart Phone  
Download a free QR-Code 2D barcode reader:  
[mobile-barcodes.com/qr-code-software/](http://mobile-barcodes.com/qr-code-software/)

Dixon is recognized as the premier manufacturer and supplier of hose fittings and accessories spanning a wide range of industrial uses. Dixon's range includes products for food, dairy processing, beverage and brewery, mobile tankers, mining, construction, chemical processing, petroleum, oilfields, refining and manufacturing.

[dixonvalve.com](http://dixonvalve.com) • *Customer Service:* 877.963.4966



*The Right Connection™*

### **Dixon Valve**

800 High Street, Chestertown, MD 21620

Fax: 800.283.4966

