

Szalai és Társa Kft.

PTFE KOMPENZÁTOR

3.1



KOMP1003-PTFE /YFM

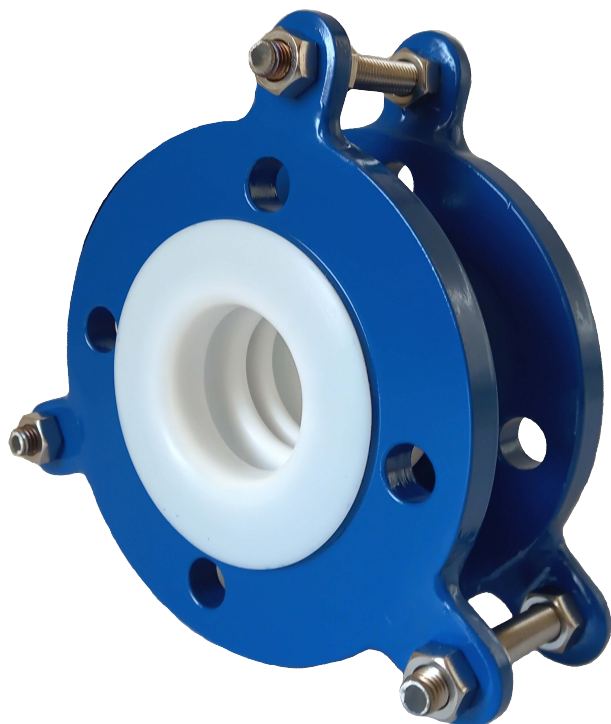

Fő jellemzők:

DN: 25-200
PN: 16/4 bar
T üzemi: -30 +200°C
csatlakozás: DIN karima
egyéb: csak fehér nem
antisztatikus kivitelben

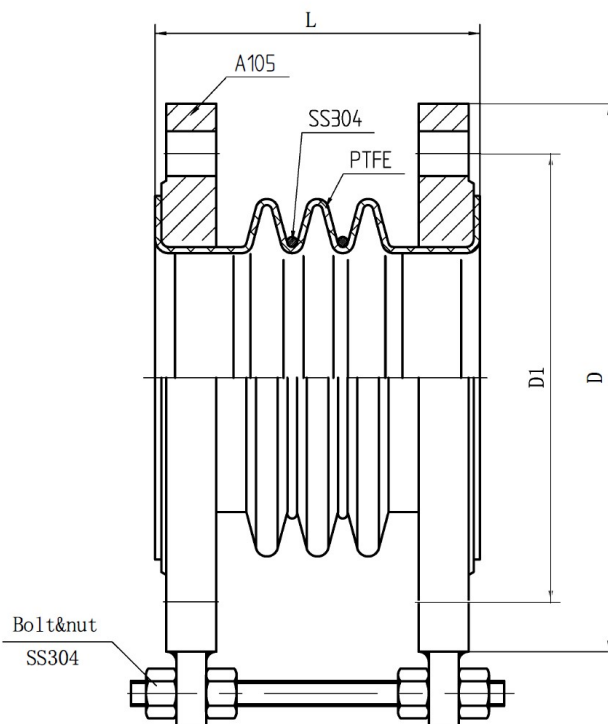
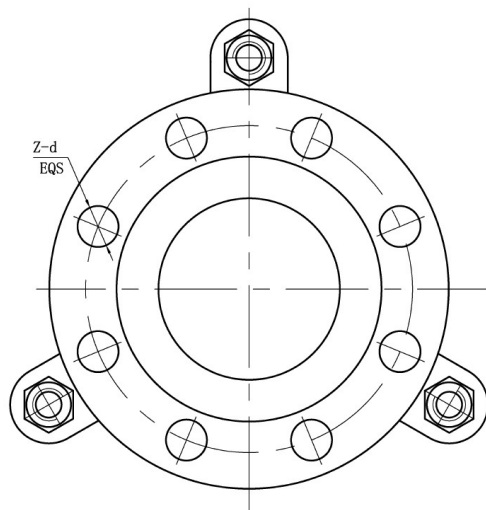

DN	L	D	D1	Z-Ød	rögzítés	Axiális mozgás ΔX (mm)	Laterális mozgás ΔY (mm)	Elfordulás $\Delta \Theta$ (°)	nominális nyomás PN (Mpa)
25	100	115	85	4-Ø14	3	±15	8	25	0.40/-0.09
32	100	140	100	4-Ø18	3	±15	10	25	0.40/-0.09
40	100	150	110	4-Ø18	3	±18	14	25	0.40/-0.09
50	100	165	125	4-Ø18	3	±18	15	25	0.40/-0.09
65	110	185	145	8-Ø18	3	±20	16	25	0.35/-0.09
80	120	200	160	8-Ø18	3	±20	16	25	0.35/-0.09
100	120	220	180	8-Ø18	3	±25	17	20	0.30/-0.09
125	130	250	210	8-Ø18	3	±27	17	18	0.30/-0.09
150	140	285	240	8-Ø22	3	±27	16	15	0.30/-0.09
200	150	340	295	8-Ø22	3	±27	15	13	0.25/-0.09

22-51118-50

fax: (1) 260 2607
tel: (1) 433 3914

raktár: 2360 Gyál, Bánki Donát utca 28.
iroda: 1108 Budapest, Venyige utca 3.

e-mail: szalaikft@szalaikft.hu
web: www.szalaikft.hu