



Szalai és Társa Kft.
1992

TZ16F4-304/316



GATE VALVES

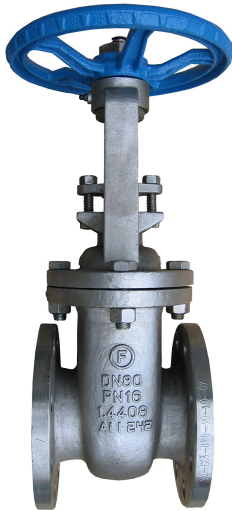

APPLICATION :

Chemical and pharmaceutical industries, pressurized air, industries, etc.

GENERAL CHARACTERISTICS :

Size DN40 - DN600.
Rising stem
Fixed non rising handwheel.
Bolted bonnet.
Metal-metal seat TRIM 10.
Flexible one piece wedge.

STANDARDS :

Manufacture according to ISO 9001 : 2015 and ISO 14001: 2015.
Directive 2014/68/EU
Pressure Tests according to DIN 3230
Face to face according to DIN 3202 - F4.
R.F. flanges according to EN 1092-1 PN16.
Design according to DIN 3352

WORKING CONDITIONS :

Maximum Working Pressure : 16 bar.
Maximum Working Temperature : -20 °C / +400 °C.

MATERIALS:

No.	Part	Material
1	Body	S Steel ASTM A351 CF8/CF8M
2	Seat	S Steel ASTM A351 CF8/CF8M
3	Disc	S Steel ASTM A351 CF8/CF8M
4	Stem	ASTM A182 F316
5	Bonnet Gasket	AISI-316 + Graphite
6	Bonnet bolt	ASTM A193 Gr. B8M
7	Nut	ASTM A194 8M
8	Bonnet	S Steel ASTM A351 CF8/CF8M
9	Back seat	S Steel ASTM A351 CF8/CF8M
10	Packing	Graphite
11	Eyebolt pin	ASTM A194 8M
12	Yoke	S Steel ASTM A351 CF8/CF8M
13	Packing gland	S Steel ASTM A351 CF8/CF8M
14	Gland plate	S Steel ASTM A351 CF8/CF8M
15	Gland eyebolt	ASTM A193 Gr. B8M
16	Nut	ASTM A194 8M
17	Stem nut	Copper alloy
18	Gland nut	Steel
19	Handwheel	Ductil Iron
20	Handwheel nut	Steel

DIMENSIONS :

DN	D	D1	D2	L	Z-Ød	Kvs	Weight
40	150	110	88	140	4-Ø18	265	13
50	165	125	102	150	4-Ø18	265	15
65	185	145	122	170	8-Ø18	423	21
80	200	160	138	180	8-Ø18	614	27
100	220	180	158	190	8-Ø18	1124	34
125	250	210	188	200	8-Ø18	1807	58
150	285	240	212	210	8-Ø22	2690	64
200	340	295	268	230	12-Ø22	4947	101
250	405	355	320	250	12-Ø26	7727	163
300	460	410	378	270	12-Ø26	11546	221
350	520	470	438	290	12-Ø26	14070	330
400	580	525	490	310	16-Ø30	18650	505
450	640	585	550	330	20-Ø30	24800	720
500	715	650	610	350	20-Ø33	30900	920
600	840	770	725	267	20-Ø36	50000	1190

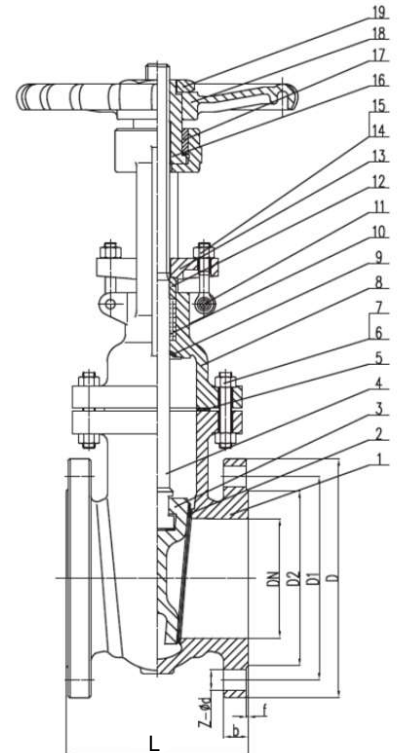

fax: (1) 260 2607
tel: (1) 433 3914

warehouse: 2360 Gyál, Bánki Donát utca 28.
office: 1108 Budapest, Venyige utca 3.

e-mail: szalaikft@szalaikft.hu
web: www.szalaikft.hu