



Szalai és Társa Kft.
1992

P1W16/10-S-PTFE-K



BUTTERFLY VALVE



APPLICATION :

Chemical & Pharma industries, corrosive fluids, Industrial applications, etc.

GENERAL CHARACTERISTICS :

Split Body wafer type Valve design.

Range from DN40 up to DN700 .

Bidirectional close.

100% tightness.

9 positions handle with locking device up to DN150.

ISO 5211 mounting pad.

Paint: Epoxy coated body RAL 5017 with 250 microns thickness min.

PTFE sealing ring 4 mm thickness with silicone elastic gasket of 6 mm thickness.

STANDARDS :

Manufacture according to : API609. DIN EN1092. JISB2032

Face to Face : EN 558-1 Series 20. Mounting between flanges EN1092-2

PN16 / ANSI150 / JIS 10K. Tightness Test according to : API 598 - DIN

3230. JIS B2003.

WORKING CONDITIONS :

Maximum Working Pressure : DN40 - DN150: 16 Bar.

DN200 - DN350: 10 bar. / DN400 - DN700: 5,5 bar.

Maximum Working Temperature : -20 °C / +200 °C.

MATERIALS:

No.	Part	Material
1	Body (*)	C.Steel A216WCB
2	Disc (**)	SS 316
3	Seat (***)	PTFE
4	Elastic Spacer	Silicone Rubber
5	Bushing	S Steel + PTFE
6	Gland	S Steel 304
7	Stem (****)	S Steel 410
8	Belleville Spring	S Steel 304
9	V-Ring	PTFE
10	Hexagonal Bolt	S Steel 304

(*) Available in SS CF8 & CF8M.

(**) Available in SS 304 & A216 WCB.

(***) Available in FEP & PFA.

(****) Available in SS 304.

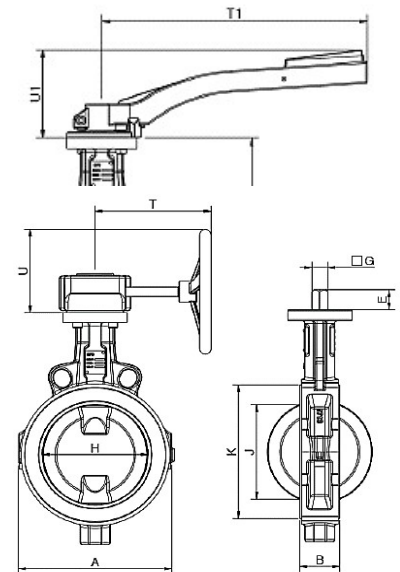
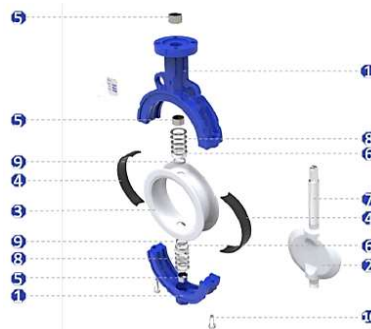

DIMENSIONS :

DN	A	B	E	G	H	J	K	T	T1	U
40	91	33	13	11	40,5	23,5	78	160	200	95
50	102	43	13	11	50,5	26,5	89,5	160	200	95
65	118	46	13	11	65,5	46,5	104,5	160	200	95
80	135	46	13	11	79,5	65	121,5	160	200	95
100	158	52	16	14	98,5	84	144	160	260	127
125	184	56	19	17	120,5	107	168,5	160	350	127
150	214	56	19	17	146,5	136	196,5	160	350	127
200	270	60	24	22	195,5	186	251,5	215		153
250	330	68	24	22	245,5	236	305,5	225		185
300	384	78	29	27	292,5	282	354,5	325		248
350	448	78	29	27	343,5	334	408,5	325		248
400	510	102	38	36	392	375,5	459	230		217
450	602	114	38	36	446	431	516	230		217
500	657	127	38	36	489	472	569	335		285
600	766	154	48	46	588	567	669	335		285
700	906	165	57	55	699,5	679	780	385		310

fax: (1) 260 2607
tel: (1) 433 3914

warehouse: 2360 Gyál, Bánki Donát utca 28.
office: 1108 Budapest, Venyige utca 3.

e-mail: szalaikft@szalaikft.hu
web: www.szalaikft.hu