



Szalai és Társa Kft.  
1992

## S800BSP-NPT-SW-316



### GLOBE VALVE



#### APPLICATION :

Nafta, steam, petrochemical, petroleum, high pressure.

#### GENERAL CHARACTERISTICS :

Size 3/8" to 2".  
Rising rotating stem OS&Y  
Bolted bonnet.  
Metal-metal seat TRIM 10  
Respect the flow direction indicated by the arrow.  
Standar Port  
class 800 lbs.

#### STANDARDS :

Manufacture according to ISO 9001 : 2008  
Directive 2014/68/EU  
Pressure Tests according to API 598 Table 6  
NPT according to ANSI B1.20.1  
Socket welding ends according to ISO 15761  
Directive 2014/34/EU

#### WORKING CONDITIONS :

Maximum Working Pressure : 132 bar.  
Maximum Working Temperature : -49 °C / +538 °C.

#### MATERIALS:

No.	Part	Material
1	Wheel nut	Carbon steel
2	Name plate	Aluminium
3	Handwheel	Carbon steel
4	Yoke nut	ASTM A582 type 303
5	Gland nut	ASTM A194 Gr. 8
6	Gland flange	ASTM A182 F304
7	Gland stud	ASTM A193 B8
8	Gland	ASTM A479 type 304
9	Packing	Graphite
10	Bolts	ASTM A193 Gr.B8
12	Stem	ASTM A479 type 316
13	Bonnet	ASTM A182 F316
14	Gasket	SS316 + Graphite
15	Seat	ASTM A479 type 316
18	Body	ASTM A182 F316
19	Disc	ASTM A182 F316

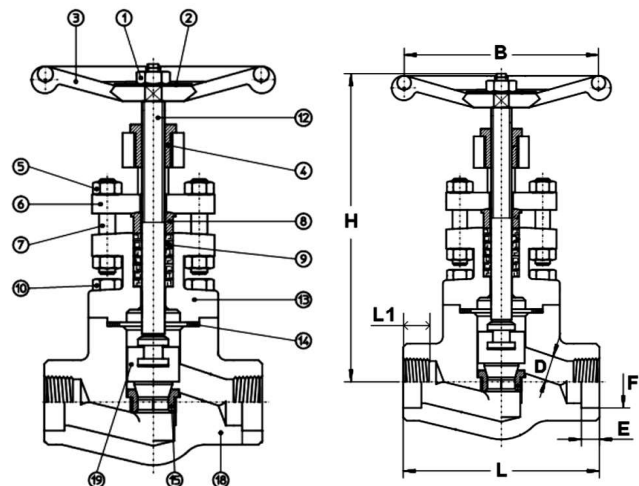

#### DIMENSIONS :

DN	ØD	L	H (open)	ØB	L1	E (SW)	ØF (SW)	Kvs m3/h	Weight
3/8"	9	80	148	90	13	11,1	17,6	1,2	1,9
1/2"	9	80	148	90	15	12,7	21,8	1,3	1,9
3/4"	13	90	165	90	18	14,5	27,2	3,3	2,18
1"	17,5	110	180	110	19	16	33,9	5,9	3,52
1 1/4"	22,5	127	213	130	20	17,5	42,7	9,5	5,3
1 1/2"	29,5	155	248	130	21	19	48,8	12,4	7,3
2"	35	170	257	180	21	22	61,2	21,6	11,3

fax: (1) 260 2607  
tel: (1) 433 3914

warehouse: 2360 Gyál, Bánki Donát utca 28.  
office: 1108 Budapest, Venyige utca 3.

e-mail: [szalaikft@szalaikft.hu](mailto:szalaikft@szalaikft.hu)  
web: [www.szalaikft.hu](http://www.szalaikft.hu)