



Szalai és Társa Kft.  
1992

# TZ14BSP-316



## GATE VALVES



### APPLICATION :

Chemical and pharmaceutical, industry, etc.

### GENERAL CHARACTERISTICS :

Full Bore.  
Rotating non rising stem .  
Bolted bonnet. Inside scREW stem.  
Screw bonnet.  
Metal-metal seat .  
Single wedge

### STANDARDS :

Manufacture Design according to GB/T12234.  
Directive 2014/68/EU  
Female BSP

### WORKING CONDITIONS :

Maximum Working Pressure : 200 WOG  
Maximum Working Temperature : -20 °C / +180 °C.

### PRESSURE-TEMPERATURE RATING

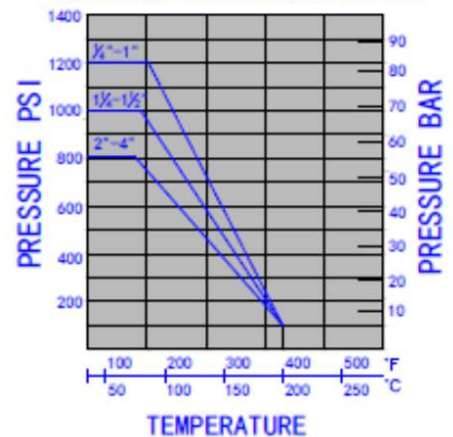

### MAIN PARTS AND MATERIALS

NO	NAME	MATERIAL
1	Body	CF8M/CF8
2	Disc	CF8M/CF8
3	Stem	316/304
4	Bonnet	CF8M/CF8
5	Gasket	PTFE
6	Gland	316/304
7	Stem Packing	PTFE/RPTFE
8	Gland	304
9	Stop Cap	304
10	Handle	ALUMINIUM
11	Nut	304

### CONFIGURATION DIMENSION

Size		L	d	H	W
DN	Inch				
15	1/2"	55	15	99	70
20	3/4"	60	20	105	70
25	1"	66	25	115	80
32	1 1/4"	76	32	130	90
40	1 1/2"	80	40	147	90
50	2"	96	50	168	100

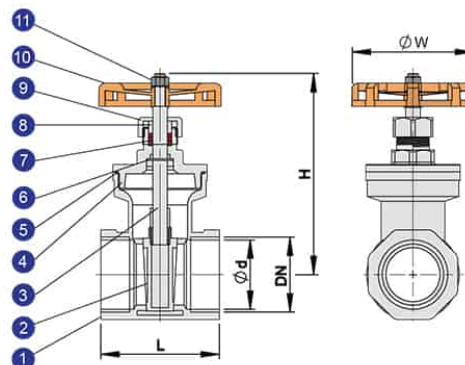

### PRESSURE TESTING

Standard Pressure	200PSI
Shell Pressure Testing	2.1Mpa
Water Seal Testing	1.5Mpa
Air Seal Testing	0.4~0.7Mpa

fax: (1) 260 2607  
tel: (1) 433 3914

warehouse: 2360 Gyál, Bánki Donát utca 28.  
office: 1108 Budapest, Venyige utca 3.

e-mail: [szalaikft@szalaikft.hu](mailto:szalaikft@szalaikft.hu)  
web: [www.szalaikft.hu](http://www.szalaikft.hu)