



Szalai és Társa Kft.  
1992

# TZ16F5-GSC



## GATE VALVES



### APPLICATION :

Water distribution, nafta, steam, petrochemical, petroleum, gas.

### GENERAL CHARACTERISTICS :

Size: DN50 - DN400.

Rising stem.

Fixed non rising handwheel.

Bolted bonnet.

Metal-metal seat TRIM 1.

Flexible one piece wedge.

### STANDARDS :

Manufacture according to ISO 9001 : 2015 and ISO 14001: 2015.

Directive 2014/68/EU

Pressure Tests according to EN 122661-1 Rate B.

Face to face according to EN 558-1 Series 15.

R.F. flanges according to EN 1092-1 PN16.

Design according to EN 1984 & EN 12516-1.

Directive 2014/34/EU.

### WORKING CONDITIONS :

Maximum Working Pressure : 16 bar.

Maximum Working Temperature : -29 °C / +425 °C.

### MATERIALS:

No.	Part	Material
1	Body	Steel A216 WCB
2	Seat	ASTM A105 WCB+13%Cr.
3	Wedge	ASTM A105 WCB+13%Cr.
4	Stem	ASTM A182 F6a
5	Stud bolt	ASTM A193 Gr. B7
6	Bonnet gasket	AISI-304 + Graphite
7	Bonnet	Steel A216 WCB
8	Back seat busing	S.Steel 13%Cr
9	Packing	Flexible Graphite
10	Yoke	Steel A216 WCB
11	Stem nut	Aluminium + Bronze
12	Ring	E51100
13	Handwheel	Cast Iron
14	Packing gland	ASTM A276-420
15	Gland flange	Steel A216 WCB

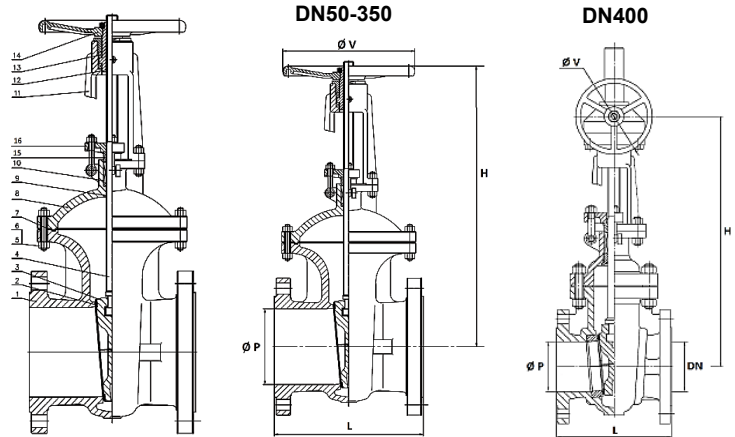

### DIMENSIONS :

DN	ØP	L	H (closed)	H (opened)	ØV	Torque Nm	Kvs	No. of cycles	Weight
50	50	250	330	390	240	35	265	15	20
65	63	270	370	460	240	75	423	19	28
80	76	280	430	515	280	90	614	19	35
100	100	300	505	590	300	106	1124	22	50
125	125	325	545	675	300	137	1807	26	61
150	150	350	610	780	350	160	2690	33	81,5
200	200	400	750	960	400	255	4940	42	125
250	250	450	900	1190	450	375	7720	46	226
300	300	500	1040	1040	500	510	11540	52	290
350	336	550	1215	1570	600	710	14070	59	425
400*	387	600	1335	1335	460	1018	18650	50	434

\* 16" Reductor / Gear Box

fax: (1) 260 2607  
tel: (1) 433 3914

warehouse: 2360 Gyál, Bánki Donát utca 28.  
office: 1108 Budapest, Venyige utca 3.

e-mail: [szalaikft@szalaikft.hu](mailto:szalaikft@szalaikft.hu)  
web: [www.szalaikft.hu](http://www.szalaikft.hu)