



Szalai és Társa Kft.
1992

V3-40BSP-GSC



BALL VALVE



APPLICATION :

Chemical, hydraulic installation, pressurized air, industry, etc.

GENERAL CHARACTERISTICS :

Full Bore.
Anti blow-out stem.
PTFE packing.
PTFE filled with 15% glass fiber seat.
Locking device.
Solid ball.
3 pieces type.
Stainless Steel Lever.

STANDARDS :

Manufacture according to ISO 9001 : 2015. Directive 2014/68/EU

Pressure Tests according to EN 12266-1, rate A.

BSP ends according to EN 12627

Certificate 3.1 on request.

WORKING CONDITIONS :

Maximum Working Pressure : 63 bar.

Maximum Working Temperature : -20 °C / +180 °C.

MATERIALS:

No.	Part	Material
1	Body	S Steel A351 CF3M
2	Ends	S Steel A351 CF3M
3	Ball	S Steel 316L
4	Body gasket	RPTFE
5	Seat	RPTFE
6	Stem	S Steel 316L
7	Handle nut	S Steel 316
8	Handle washer	S Steel 304
9	Gland nut	S Steel 304
10	Thrust washer	PTFE
11	Bolt	S Steel 304
12	Nut	S Steel 304
13	Washer	S Steel 304
14	Packing	PTFE
15	Locking device	S Steel 304
16	Handle	S Steel 304
17	Handle cover	Plastic

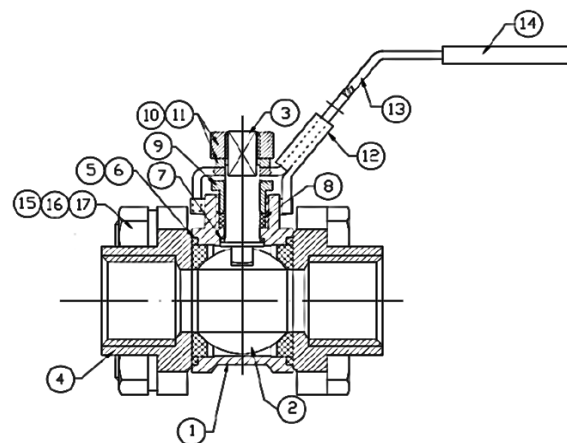

DIMENSIONS :

DN	A	B	C	D	Weight
1/4"	11,6	52	48	100	0,33
3/8"	11,6	52	48	100	0,34
1/2"	15	63,4	52	100	0,49
3/4"	20	71	61	127	0,64
1"	25	80,6	65	127	0,96
1 1/4"	32	94	79	154	1,37
1 1/2"	38	104	83	154	2,2
2"	50	126,4	97	192	3,75
2 1/2"	65	160	135	244	6,85
3"	80	179,5	144	244	10,2

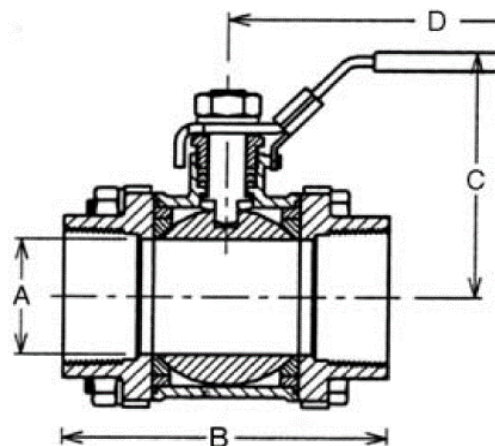

fax: (1) 260 2607
tel: (1) 433 3914

warehouse: 2360 Gyál, Bánki Donát utca 28.
office: 1108 Budapest, Venyige utca 3.

e-mail: szalaikft@szalaikft.hu
web: www.szalaikft.hu