



Szalai és Társa Kft.
1992

V3-40F1-GSC



BALL VALVE

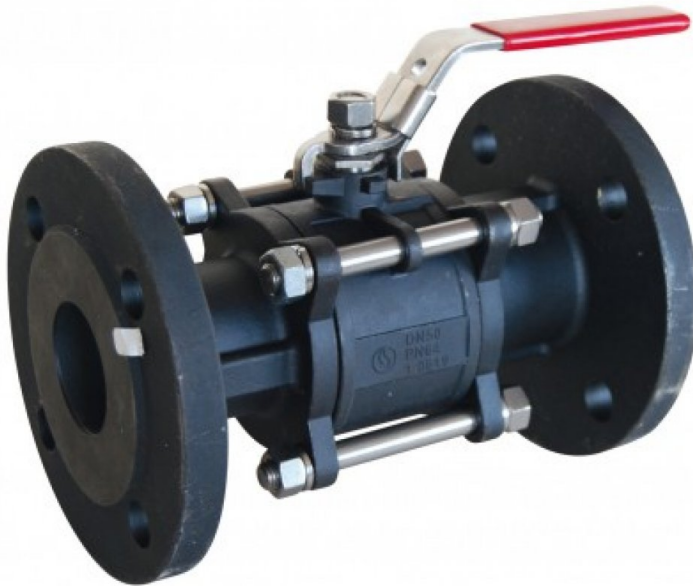

APPLICATION :

Chemical, pharmaceutical and petrochemical industries.

GENERAL CHARACTERISTICS :

Full Bore.
Anti blow-out stem.
3-pcs body type.
PTFE filled with stainless steel seat.

STANDARDS :

Design according to EN 12516.
Directive 2014/68/EU
Pressure Tests according to EN 12266-1 rate A.
RF Flanged ends according to EN 1092-1 PN40.

WORKING CONDITIONS :

Maximum Working Pressure : 40 bar.
Maximum Working Temperature : - 30 °C / + 180 °C.

MATERIALS:

No.	Part	Material
1	Body	C Steel EN 1.0619
2	Ball	S Steel A351 CF8M
3	Stem	S Steel 316
4	Ends	C Steel EN 1.0619
5	Seat	PTFE + 50% SS 316
6	Thrust washer	PTFE
7	Stem packing	PTFE
8	Packing follower	PTFE
9	Gland bush	S Steel 304
10	Handle	S Steel 304
11	Handle cover	Plastic
12	Stem nut	S Steel 304
13	Handle nut	S Steel 304
14	Locking device	S Steel 304
15	Elastic washer	S Steel 301
16	Tab washer	S Steel 304
17	Body bolt	S Steel 304
18	Body washer	S Steel 304
19	Bolt nut	S Steel 304

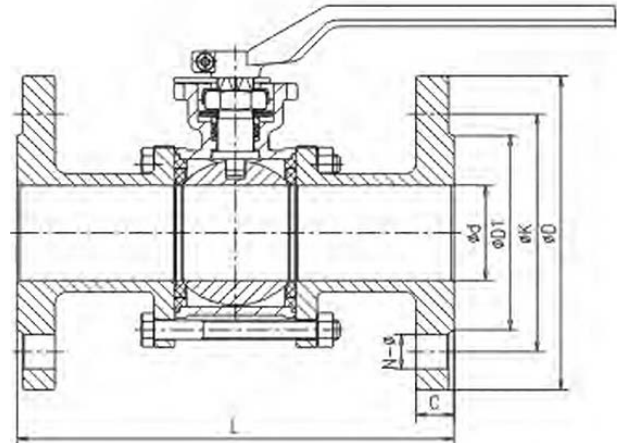

DIMENSIONS :

DN	L	D	k	D1	d	C	NxØZ	Par (Nm)	Weight
15	130	95	65	45	15	16	4 X 7	7,6	2,04
20	150	105	75	58	20	18	4 X 7	14,5	2,9
25	160	115	85	68	25	18	4 X 7	21	3,66
32	180	140	100	78	32	18	4 X 7	25	5,4
40	200	150	110	88	40	18	4 X 9	35	6,76
50	230	165	125	102	50	20	4 X 9	60	9,75
65	290	185	145	122	65	22	4 X 11	80	15,36
80	310	200	160	138	80	24	4 X 11	88	21,33
100	350	220	190	162	100	24	4 X 11	190	36,7

fax: (1) 260 2607
tel: (1) 433 3914

warehouse: 2360 Gyál, Bánki Donát utca 28.
office: 1108 Budapest, Venyige utca 3.

e-mail: szalaikft@szalaikft.hu
web: www.szalaikft.hu