



Szalai és Társa Kft.
1992

VDM3-40B-316L



BALL VALVE



APPLICATION :

Chemical, pharmaceutical and petrochemical industries.
Hydraulic installations. Compressed air.

GENERAL CHARACTERISTICS :

Full Bore.
Anti blow-out stem.
ISO 5211 Mounting pad.
3-pcs body type.
PTFE filled with stainless steel seat.

STANDARDS :

Design according to EN 12516.
Directive 2014/68/EU
Pressure Tests according to EN 12266-1 rate A.
Butt weld ends according to EN 12627

WORKING CONDITIONS :

Maximum Working Pressure : 63 bar.
Maximum Working Temperature : - 30 °C / + 180 °C.

NO.	PART NAME	MATERIAL	QTY
1	BODY	CF3M	1
2	BALL	SS316L	1
3	BOLT	SS304	4-6
4	NUT	SS304	4-12
5	PACKING	PTFE	1
6	STEM	SS316L	1
7	GLAND	SS304	1
8	NUT	SS304	1
9	CAP	CF3M	2
10	SEAT	RPTFE	2
11	THRUST WASHER	PTFE	1
12	HANDLE	SS304	1
13	HANDLE COVER	PVC	1
14	LOCK	SS304	1
15	O-RING	VITON	1

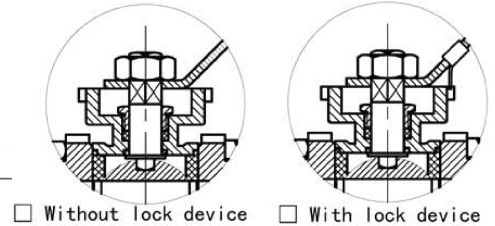
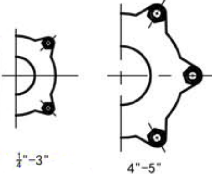
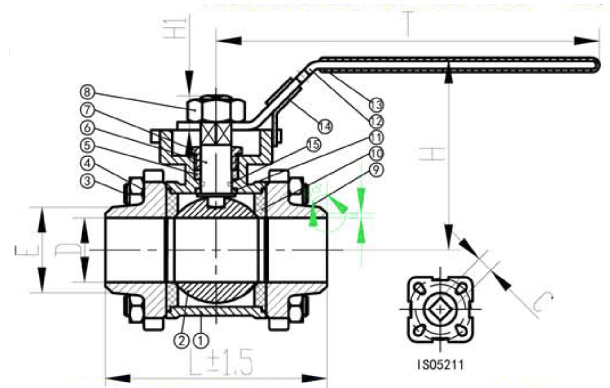

SIZE	1/4"	3/8"	1/2"	3/4"	1"	1,1/4"	1,1/2"	2"	2,1/2"	3"
DN	8	10	15	20	25	32	40	50	65	80
D	8	10	15	20	25	32	40	50	65	80
L	60	60	65	75	83	98	112	135	175	198
H	70	70	80	74	86	95	116	123	145	154
E	13,7	17,2	21,3	26,7	33,5	42,2	48,3	60,5	73,1	88,9
T	131	131	131	131	167	167	193	193	242	272
C	9	9	9	9	11	11	14	14	17	17
NM	3	3	3,5	6	6	7,5	18	28	32	38
ISO5211	F03/F04	F03/F04	F03/F04	F03/F04	F04/F05	F04/F05	F05/F07	F05/F07	F07/F10	F07/F10
KG	0,55	0,58	0,645	0,81	1,085	1,66	2,195	3,025	5,91	8,135

fax: (1) 260 2607
tel: (1) 433 3914

warehouse: 2360 Gyál, Bánki Donát utca 28.
office: 1108 Budapest, Venyige utca 3.

e-mail: szalaikft@szalaikft.hu
web: www.szalaikft.hu