



Szalai és Társa Kft.
1992

VM2-40F4-316



2 PIECES BALL VALVE S.STEEL FLANGED ENDS DIN PN40



APPLICATION :

Chemical and petrochemical industries. Hydraulic installations. Heating and water distribution.

GENERAL CHARACTERISTICS :

Full Bore.
Anti blow-out stem.
ISO 5211 Mounting pad.
Split body type.
Double Anti Static device.
Hollow ball for ND125-150.

STANDARDS :

Design according to EN 12516-1.
Directive 2014/68/EU: CE No. 0035 Risk Category II Module D1.
Pressure Tests according to API 598 Table 6.
Flanged ends according to EN 1092-1 PN16.

WORKING CONDITIONS :

Maximum Working Pressure : 40 bar
Maximum Working Temperature : - 30 °C / + 180 °C.

CONSTRUCTION :

No.	Part	Material
1	Body	S.Steel A351 CF8M
2	Ends	S.Steel A351 CF8M
3	Ball	S.Steel 316
4	Stem	S.Steel 316
5	Seat	PTFE + 3% FG
6	Body Gasket DN15-32	PTFE + 15% Graphite
	Body Gasket DN40-150	S.Steel 304 + Graphite
7	Thrust Washer	PTFE + 15% Graphite
8	O ring	FKM
9	Packing	PTFE
10	Gland	S.Steel 304
11	Elastic Ring	S.Steel 301
12	Nut	S.Steel 304
13	Washer	S.Steel 304
14	Washer	S.Steel 304
15	Handle	S.Steel 304
16	Handle Cover	Plastic
17	Nut	S.Steel 304
18	Stud bolt	S.Steel 304
19	Spring Washer	S.Steel 304
20	Locking Device	S.Steel 304
21	Stopper	S.Steel 304

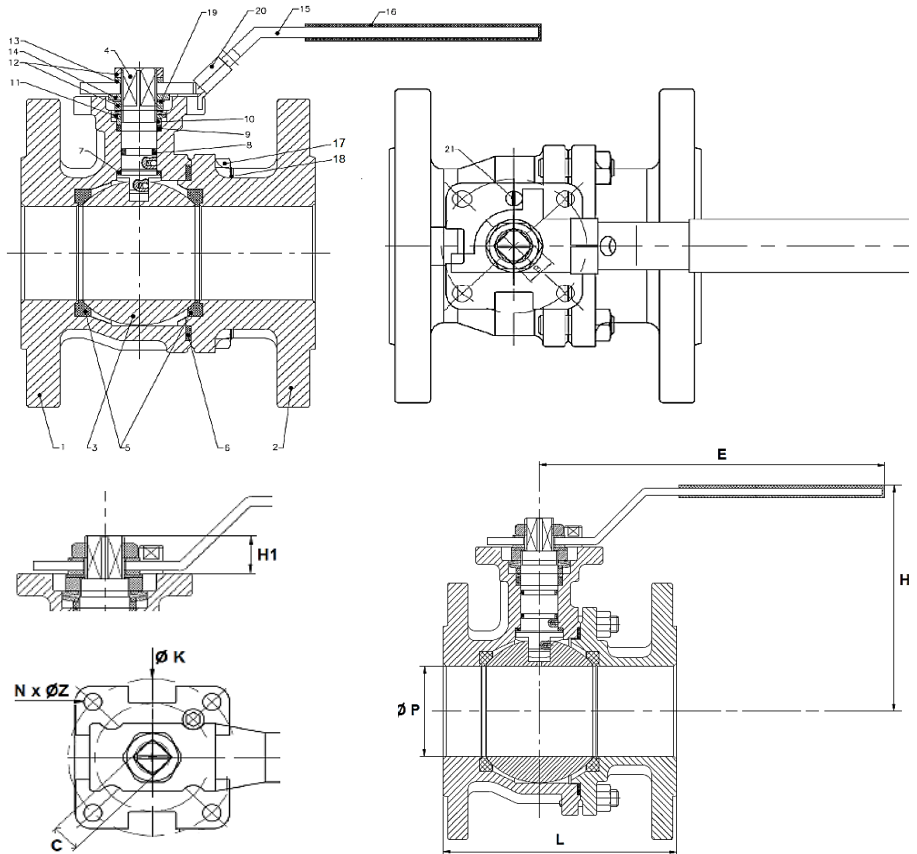

DN	ØP	L	E	H	H1	C	ØK	N x ØZ	ISO 5211	Torque Nm	Weight
15	15	115	161	82,7	11	9	42	4 X 6	F04	6	2,20
20	20	120	161	83,2	10	9	42	4 X 6	F04	8	3,02
25	25	125	161	88,2	11	11	50	4 X 7	F05	10	3,79
32	32	130	205	111	16,5	14	50	4 X 7	F05	14	5,74
40	40	140	205	112	16,5	14	70	4 X 9	F07	20	6,79
50	50	150	205	120	16,5	14	70	4 X 9	F07	30	9,33
65	65	170	325	160	21	17	102	4 X 11	F10	36	15,20
80	80	180	325	170	21	17	102	4 X 11	F10	60	19,58
100	100	190	325	186	21	17	102	4 X 11	F10	95	27,36
125	125	325	520	211	34	27	125	4 X 14	F12	150	38,86
150	150	350	620	228	34	27	125	4 X 14	F12	210	50,72

fax: (1) 260 2607
tel: (1) 433 3914

warehouse: 2360 Gyál, Bánki Donát utca 28.
office: 1108 Budapest, Venyige utca 3.

e-mail: szalaikft@szalaikft.hu
web: www.szalaikft.hu