

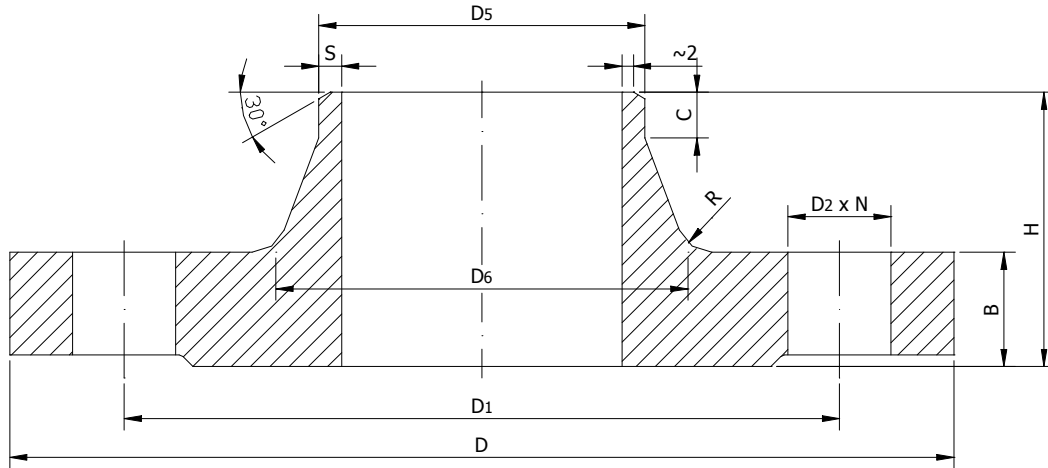

Szalai és Társa Kft.  
1992

## HEGESZTHETŐ TOLDATOS KARIMA PN160

MSZ 2928 DIN 2638



Anyagminőség: igény szerint C22.3  
RSt-37.2  
WNr.1.4301, 1.4307, 1.4541 1.4404  
stb

DN	D	B	H	D5	S	D6	D1	D2	N	R	C	kg
10	100	20	45	17,2	2,6	32	70	14	4	4	6	1,10
15	105	20	45	21,3	2,6	34	75	14	4	4	6	1,20
20												
25	140	24	58	30,0	2,9	48	100	18	4	4	8	2,61
32				33,7								
40	170	28	64	44,5	3,6	65	125	22	4	6	10	4,35
50	195	30	75	57,0	4,0	86	145	26	4	6	10	6,25
65	220	34	82	76,1	5,0	108	170	26	8	6	12	8,70
80	230	36	86	88,9	6,3	120	180	26	8	8	12	10,00
100	265	40	100	108,0	8,0	145	210	30	8	8	12	14,90
125	315	44	115	133,0	10,0	180	250	33	8	8	14	23,90
150	355	50	128	159,0	12,5	210	290	33	12	10	14	33,90
200	430	60	140	219,1	16,0	278	360	36	12	10	16	60,10
250	515	68	155	273,0	20,0	340	430	42	12	12	18	96,00
300	585	78	175	323,9	22,0	400	500	42	16	12	18	138,00

fax: (1) 260 2607  
tel: (1) 433 3914

raktár: 2360 Gyál, Bánki Donát utca 28.  
iroda: 1108 Budapest, Venyige utca 3.

e-mail: [szalaikft@szalaikft.hu](mailto:szalaikft@szalaikft.hu)  
web: [www.szalaikft.hu](http://www.szalaikft.hu)