



Szalai és Társa Kft.
1992

V2-MONOBLOCK SW/NPT/BSP A105 /316-PEEK



BALL VALVE

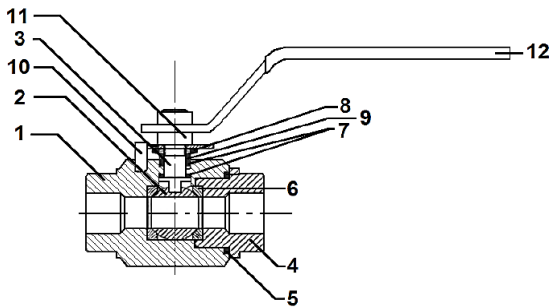

sizes 2,1/2", 3" and 4"
are 3-pcs body design

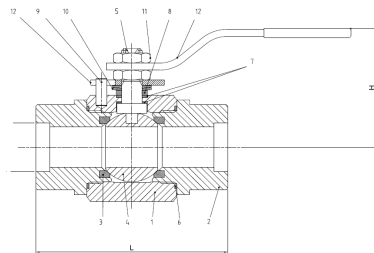

APPLICATION :

Chemical and pharmaceutical industries, petrochemical industries, hydraulic installation, Gas.

GENERAL CHARACTERISTICS :

Range: DN-1/4" - 2".

Full Bore.

Anti blow-out stem

PEEK seats.

Fire safe according to B.S. 6755 part.2

Optional Locking device.

Class 800 carbon steel CS and stainless steel SS

STANDARDS :

Manufacture according to ISO 9001 : 2008

Directive 2014/68/EU

designing according to ASME B16.34

Pressure Tests according to EN API 598, table 6

Female cylindrical BSP threaded ends according to ISO 228-1

NPT threaded ends according to ANSI B2.1

Optional: ATEX: Group II Category 2 G/2D Zone 1 & 21 Zone 2 & 22 optional marking.

Materials according to NACE MR 01-75

WORKING CONDITIONS :

Maximum Working Pressure : 138 bar (800 lbs) / 250 bar (1500 lbs)

Maximum Working Temperature : - 20 + 250 °C.

MATERIALS:

No.	Part	Material CS	Material SS
1	Body	ASTM A105	ASTM A182 F316
2	Ball	ASTM A182 F316	ASTM A182 F316
3	Stem	ASTM A182 F316	ASTM A182 F316
4	Ends	ASTM A105	ASTM A182 F316
5	Body gasket	Graphite	Graphite
6	Seat	PEEK	PEEK
7	Stem gasket	FKM	FKM
8	Disc springs	Steel	Steel
9	Packing gland	ASTM A105	ASTM A182 F304
10	Stop	FE P11 (UNI5867)	FE P11 (UNI5867)
11	Nut	Steel 6S	Steel 6S
12	Handle	FE P11 (UNI5867)	FE P11 (UNI5867)

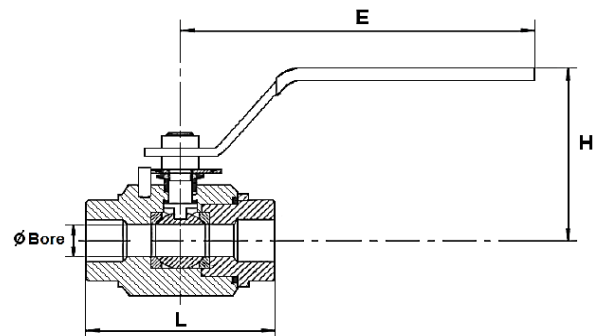

DIMENSIONS :

DN	ØBore	L	E	H	C	ØY	ØSW	L1	Weight
1/4"	10	67	148	72	5	8	14,3	9,5	0,6
3/8"	10	67	148	72	5	8	17,8	9,5	0,6
1/2"	15	75	148	75	5,5	10	21,8	9,5	0,8
3/4"	20	90	180	85	7,5	12	27,3	11,5	1,5
1"	25	105	180	95	7,5	12	34	13	2
1 1/4"	30	120	240	100	9	14	42,6	14	3,3
1 1/2"	38	135	240	105	9	14	48,7	16	4,5
2"	48	155	280	115	9	14	61,3	17	6

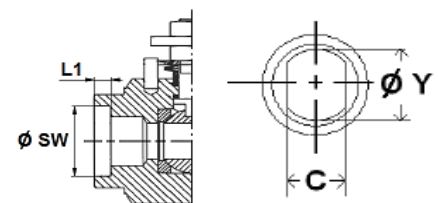

fax: (1) 260 2607
tel: (1) 433 3914

warehouse: 2360 Gyál, Bánki Donát utca 28.
office: 1108 Budapest, Venyige utca 3.

e-mail: szalaikft@szalaikft.hu
web: www.szalaikft.hu