



Szalai és Társa Kft.  
1992

**TZ16F5-304/316**



**GATE VALVES**



**APPLICATION :**

Chemical and petrochemical industries.

**GENERAL CHARACTERISTICS :**

Size: DN50 - DN300.

Rising stem.

Fixed non rising handwheel.

Bolted bonnet.

Metal-metal seat TRIM 10.

Flexible one piece wedge.

**STANDARDS :**

Manufacture according to ISO 9001 : 2015 and ISO 14001: 2015.

Directive 2014/68/EU

Pressure Tests according to EN 122661-1 Rate D.

Face to face according to EN 558-1 Series 14.

R.F. flanges according to EN 1092-1 PN16.

Design according to EN 1984 & EN 12516-1.

directive 2014/34/EU.

**WORKING CONDITIONS :**

Maximum Working Pressure : 16 bar.

Maximum Working Temperature : -49 °C / +538 °C.

**MATERIALS:**

No.	Part	Material
1	Body	S. Steel ASTM A351 CF8 / CF8M
2	Seat	S. Steel ASTM A351 CF8 / CF8M
3	Wedge	S. Steel ASTM A351 CF8 / CF8M
4	Stem	ASTM A182 F316
5	Stud bolt	ASTM A193 Gr. B8
6	Bonnet gasket	AISI-316 + Graphite
7	Bonnet	S. Steel ASTM A351 CF8 / CF8M
8	Back seat busing	Coating 13Cr
9	Packing	Graphite
10	Yoke	S. Steel ASTM A351 CF8 / CF8M
11	Stem nut	Aluminium + Bronze
12	Ring	E51100
13	Handwheel	Cast Iron
14	Packing gland	S. Steel ASTM A351 CF8 / CF8M
15	Gland flange	S. Steel ASTM A351 CF8 / CF8M

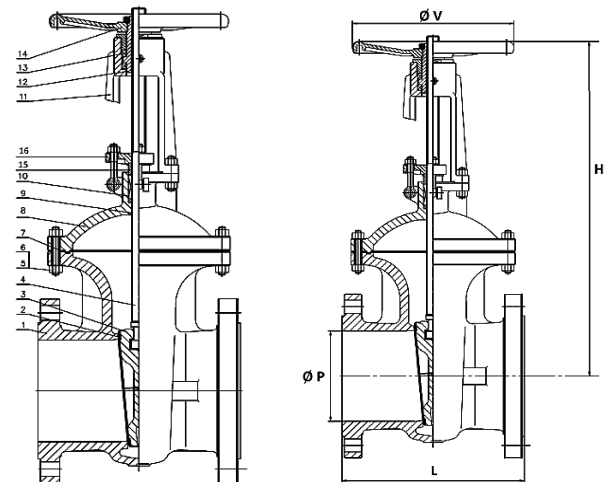

**DIMENSIONS :**

DN	ØP	L	H (closed)	H (opened)	ØV	Torque Nm	Kvs	No. of cycles	Weight
50	50	250	356	299	240	37	265	15	15
65	63	270	463	385	240	68	423	20	21
80	78	280	459	372	280	85	614	18	27
100	100	300	544	437	300	107	1124	23	34
125	125	325	685	548	300	165	1807	28	58
150	150	350	757	595	350	180	2690	33	64
200	203	400	988	768	400	265	4947	38	101
250	254	450	1166	900	450	410	7727	45	163
300	300	500	1400	1075	500	540	11546	55	221

fax: (1) 260 2607  
tel: (1) 433 3914

warehouse: 2360 Gyál, Bánki Donát utca 28.  
office: 1108 Budapest, Venyige utca 3.

e-mail: [szalaikft@szalaikft.hu](mailto:szalaikft@szalaikft.hu)  
web: [www.szalaikft.hu](http://www.szalaikft.hu)