



Szalai és Társa Kft.
1992

TZ150F-WCB



GATE VALVES



APPLICATION :

Water distribution, nafta, steam, petrochemical, petroleum, gas.

GENERAL CHARACTERISTICS :

Size: NPS 2" - 16"

Full bore

Fire safe API 6FA

Rising, non-rotating stem

Fixed non rising handwheel

Flexible one piece wedge

Flanges R.F. Class 150 (PN20)

Carbon steel body

Bolted bonnet and gland pack

½ stellite (Trim 8 , seat with stellite)

Acrylic grey painting RAL 7001 color, 60 µm thickness

Corrosion allowance

WORKING CONDITIONS :

Maximum Working Pressure : 20 bar.

Maximum Working Temperature : -29 °C / +425 °C.

MATERIALS:

No.	Part	Material
1	Body	ASTM A216 WCB
2	Seat	ASTM A105 + Stellite Gr. 6
3	Wedge	ASTM A216 WCB +13 Cr.
4	Stem	ASTM A182 F6a
5	Stud bolt	ASTM A193 Gr. B7
6	Nut	ASTM A194 Gr. 2H
7	Bonnet gasket	AISI-304 + Graphite
8	Bonnet	ASTM A216 WCB
9	Back seat busing	ASTM A276-420
10	Packing	Flexible Graphite
11	Yoke	ASTM A216 WCB
12	Stem nut	Aluminium + Bronze
13	Ring	E51100
14	Handwheel	Cast Iron
15	Packing gland	ASTM A276-420
16	Gland flange	ASTM A216 WCB
17	Gland bolting	Steel GB/T 699 Grade 45

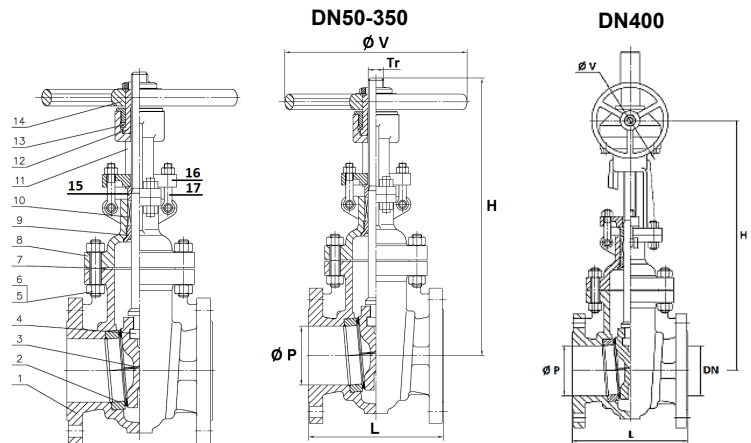

DIMENSIONS :

NPS	ØP	L	H (closed)	H (opened)	ØV	Torque Nm	Kvs	No. of cycles	Weight
2	51	178	355	410	200	70	265	15	18
2,1/2	63,5	191	390	470	240	68	423	20	23,2
3	76	203	421	500	240	69	614	18	31
4	102	229	479	581	300	114	1124	23	45
5	127	254	550	690	350	135	1807	28	69
6	152	267	593	745	350	200	2690	33	76
8	203	292	768	971	400	220	4940	38	127
10	254	330	905	1160	400	300	7720	45	176
12	305	356	1071	1376	500	340	11540	55	281
14	334	381	1185	1508	600	430	14070	60	330
16	387	600	1335	1335	460	450	18650	52	434

* 16" Reductor / Gear Box

fax: (1) 260 2607
tel: (1) 433 3914

warehouse: 2360 Gyál, Bánki Donát utca 28.
office: 1108 Budapest, Venyige utca 3.

e-mail: szalaikft@szalaikft.hu
web: www.szalaikft.hu