



Szalai és Társa Kft.
1992

TZ100F7-15MO3



GATE VALVES



*the image is for illustration purposes only,
exact appearance based on the current version on request

APPLICATION :

Water, steam, oil, etc.

GENERAL CHARACTERISTICS :

Size: NPS 2" - 6"
Rising, non-rotating stem
Fixed non rising handwheel
Flexible one piece wedge
Flanges DIN 2526
Face to face DIN 3202
Bolted bonnet and gland pack
Corrosion allowance

WORKING CONDITIONS :

Maximum Working Pressure : 100 bar.
Maximum Working Temperature : -29 °C / +450 °C.

MATERIALS:

No.	Part	Material
1	Wedge	WC1+13Cr
2	Body	WC1+13Cr
3	Gasket	304 + Graphite
4	Bolt	B7
5	Nut	2H
6	Stem	F6a
7	Bonnet	WC1
8	Packing	Graphite
9	Gland Flange	WC1
10	Nut	2H
11	Bolt	B7
12	Stem Nut	Brass
13	Hand Wheel	Ductile Iron

DIMENSIONS :

DN	NPS	L	D	D1	D2	b	f	n-Z
50	2"	250	195	145	102	30	3	4-26
80	3"	310	230	180	138	36	3	8-26
100	4"	350	265	210	162	40	3	8-30
150	6"	450	355	290	218	44	3	12-33

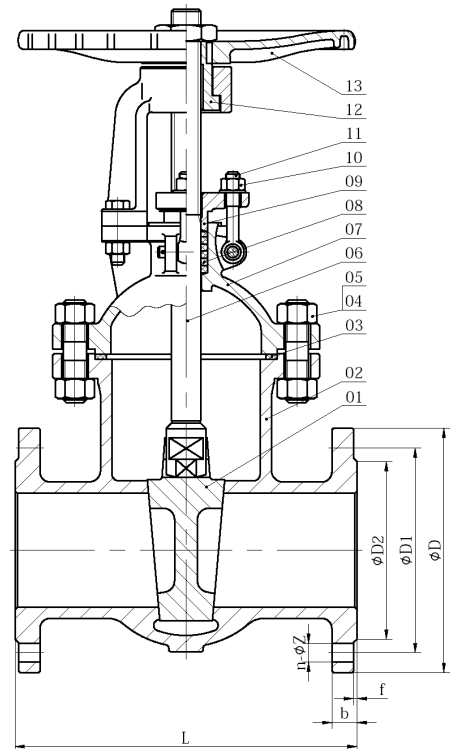

fax: (1) 260 2607
tel: (1) 433 3914

warehouse: 2360 Gyál, Bánki Donát utca 28.
office: 1108 Budapest, Venyige utca 3.

e-mail: szalaikft@szalaikft.hu
web: www.szalaikft.hu