



Szalai és Társa Kft.
1992

TZ150F-A105



GATE VALVES



*the image is for illustration purposes only,
exact appearance based on the current version on request

APPLICATION :

Water, steam, oil, etc.

GENERAL CHARACTERISTICS :

Size: NPS 1/2" - 2"
Rising, non-rotating stem
Fixed non rising handwheel
Flexible one piece wedge
Flanges ASME B16.5
Face to face ASME 16.10
Bolted bonnet and gland pack
Corrosion allowance

WORKING CONDITIONS :

Maximum Working Pressure : 10 bar.
Maximum Working Temperature : -29 °C / +425 °C.

MATERIALS:

No.	Part	Material
1	Body	A105
2	Seat	13 Cr
3	Wedge	13Cr
4	Stem	13Cr
5	Gasket	SS + Graphite
6	Bonnet	A105
7	Bolt	B7
8	Packing	Graphite
9	Gland	13Cr
10	Gland Flange	A105
11	Nut	2H
12	Bolt	B7
13	Stem Nut	410
14	Handwheel	Malleable Iron

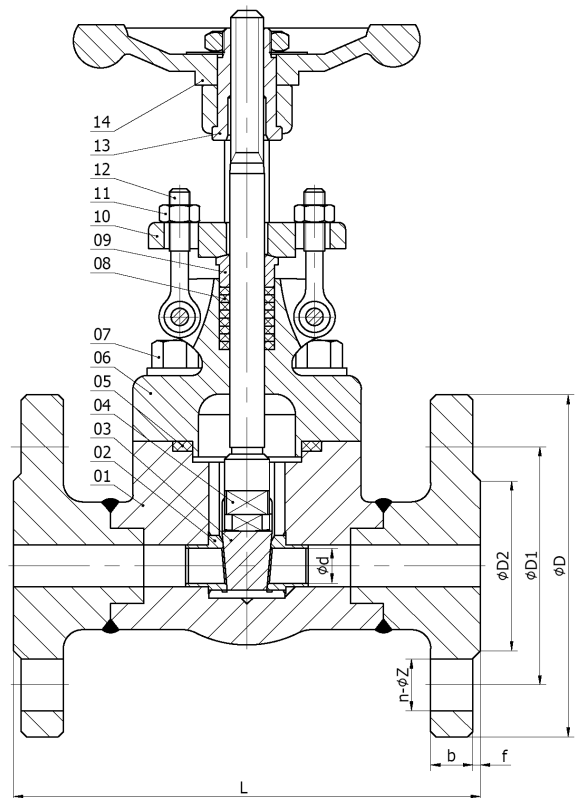

DIMENSIONS :

DN	NPS	L	d	D	D1	D2	b	f	n-Z
15	1/2"	108	10,5	90	60,3	34,9	8,0	2	4-16
20	3/4"	117	13,5	100	69,9	42,9	8,9	2	4-16
25	1"	127	18	110	79,4	50,8	9,6	2	4-16
32	1-1/4"	140	23	115	88,9	63,5	11,2	2	4-16
40	1-1/2"	165	29	125	98,4	73,0	12,7	2	4-16
50	2"	178	36	150	120,7	92,1	14,3	2	4-19

fax: (1) 260 2607
tel: (1) 433 3914

warehouse: 2360 Gyál, Bánki Donát utca 28.
office: 1108 Budapest, Venyige utca 3.

e-mail: szalaikft@szalaikft.hu
web: www.szalaikft.hu