



Szalai és Társa Kft.  
1992

# RD64F2-GSC



## CHECK VALVES



### APPLICATION :

Water, steam, oil, etc.

### GENERAL CHARACTERISTICS :

Range from DN50 up to DN300 .

Installation in horizontal position.

Opening pressure 0,1 bar  
seat with spring

### STANDARDS :

Manufacture according to DIN 3356

Face to Face : DIN 3202-F2

End flange: DIN 2526

Mounting between flanges : PN16/40/64 EN 1092-1

Inspection and test: DIN 3230

Directive 2014/68/EU

### WORKING CONDITIONS :

Maximum Working Pressure : 64 bar.

Maximum allowed fluid Temperature : -29 °C / +425 °C.

\*the image is for illustration purposes only,  
exact appearance based on the current version on request

### MATERIALS :

No.	Part	Material
1	Body	WCB+13Cr
2	Disc	A105+13Cr
3	Gasket	304+Graphite
4	Bonnet	WCB
5	Bolt	B7

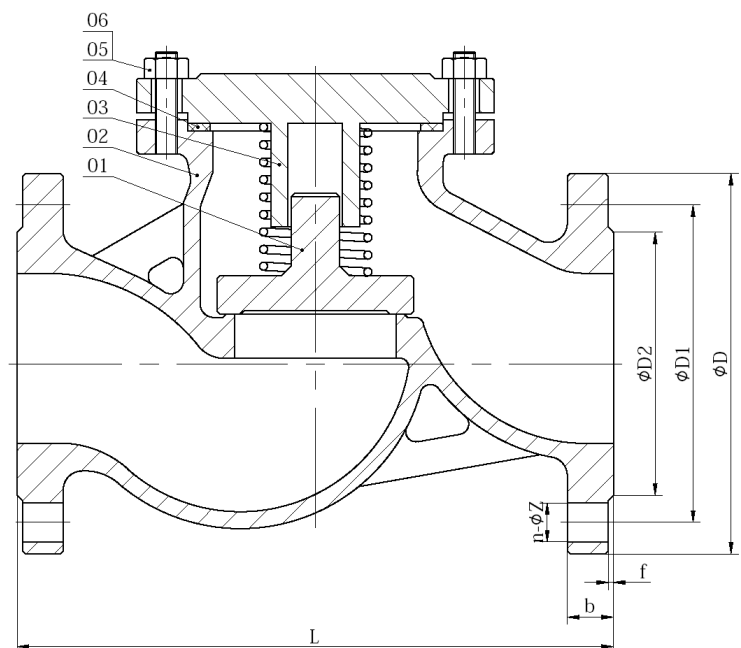

### DIMENSIONS :

DN	L	D	D1	D2	b	n-ØZ	f
50	300	180	135	102	26	4-22	3
65	340	205	160	122	26	8-22	3
80	380	215	170	138	28	8-22	3
100	430	250	200	162	30	8-26	3
125	500	295	240	188	34	8-30	3
150	550	345	280	218	36	8-33	3
200	650	415	345	285	42	12-36	3
250	775	470	400	345	46	12-36	3
300	900	535	460	410	52	16-36	4

fax: (1) 260 2607  
tel: (1) 433 3914

warehouse: 2360 Gyál, Bánki Donát utca 28.  
office: 1108 Budapest, Venyige utca 3.

e-mail: [szalaikft@szalaikft.hu](mailto:szalaikft@szalaikft.hu)  
web: [www.szalaikft.hu](http://www.szalaikft.hu)