



Szalai és Társa Kft.
1992

TZ800-SW-LF2



GATE VALVES



APPLICATION :

Water, Uapáæ .

GENERAL CHARACTERISTICS :

Range from DPFÍ up to DpÍ €.

STANDARDS :

Design B T æ ~ æç ! ^ Å& : ÚÁ €G

ÚY Á) â • Å } † ! { Å Å Ú Ó F Í È F

NPT ends conform to ANSI B1.20.1

Test B Å •] ^ & Å } † ! { Å Å Ú Á J I

WORKING CONDITIONS (EPDM):

Maximum Working Pressure : FÍ € bar.

Maximum Working Temperature : -I Î °C / +H€€ °C.

*the image is for illustration purposes only,
exact appearance based on the current version on request

A5H9F-5 @G:

No.	Part Name	Material
1	Body	A350 LF2
2	Seat Ring	A276 410
3	Disc	A182 F6a
4	Stem	A276 410
5	Gasket	SS304+Graphite
6	Bonnet	A350 LF2
7	Bolt	A320 L7
8	Pin	Stainelss Steel
9	Gland	A276 410
10	Gland Eyebolt	A320 L7
11	Gland Flange	A350 LF2
12	Nut	A194 7
13	Yoke Nut	AISI 1035
14	Handwheel Nut	Carbon Steel
15	Handwheel	Malleable Iron
16	Packing	Graphite

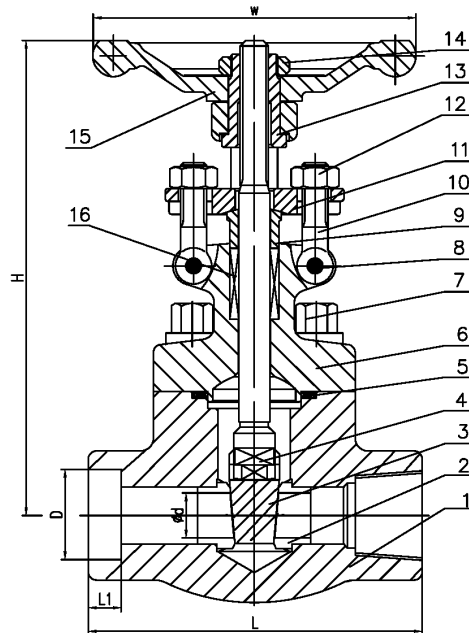

8-A9BG-CBG:

inch	DN	d	D	L1	NPT	L	H	w
1/2"	15	10,5	21,7	9,6	1/2"	79	161	100
3/4"	20	13,5	27,1	12,7	3/4"	92	163	100
1"	25	18	33,8	12,7	1"	111	196	125
1,1/4"	32	24	42,5	12,7	1,1/4"	120	223	160
1,1/2"	40	29	48,6	12,7	1,1/2"	120	251	160
2"	50	36,5	61,1	15,7	2"	140	290	180

fax: (1) 260 2607
tel: (1) 433 3914

warehouse: 2360 Gyál, Bánki Donát utca 28.
office: 1108 Budapest, Venyige utca 3.

e-mail: szalaikft@szalaikft.hu
web: www.szalaikft.hu